

User Manual	Manual de Usuario	Manuel de l'Utilisateur
Customer Service US: 1-800-645-2986	Servicio de atención al Cliente US: 1-800-645-2986	Service à la clientèle Canada: 888-645-2986

PRODUCT DESCRIPTION

Model _____

Forklift Maintenance Platform



NOTE:

Owner and operator must read and understand this instruction manual before operation.

Ver:18001

Product Description

RevA: 10/2018

THANK YOU FOR USING THIS WORKING PLATFORM. FOR YOUR SAFETY AND CORRECT OPERATION, PLEASE CAREFULLY READ THIS INSTRUCTION BEFORE USING IT.

NOTE: All of the information reported herein is based on data available at the moment of printing. The factory reserves the right to modify its own products at any moment without notice and incurring in any sanction. So it is suggested to always verify possible updates.

Please carefully read this operation manual and 'working platforms on forklift trucks guidance note PM28' before use.

1 Instructions

This platform is specially designed matched with the forklift according to requirements of 'working platforms on forklift trucks guidance note PM28'. It ensures your safety with its multiple safeguards. The operation is very convenient. Its folding structure makes it easy for transportation and storage.

2 Parameters

Model	Person Qty	Min. truck capacity	H×W×D (mm)	Notes
NK30-A	single	750kg	1900×950×950	With lift and right gate
NK30-B	single	750kg	1900×1200×1000	With lift and right gate
	double	1250kg	1900×1200×1000	With lift and right gate
NK30-C	single	750kg	1900×1000×1000	With lift and right gate
	double	1250kg	1900×1000×1000	With lift and right gate

3 Installation

- 3.1 Lift the safeguard and fix it with the back rail by the inner pin. Fix the back rail with the base by pins.
- 1.2 Lift the front rail and open the left and right doors. Fix them by pins.
- 1.3 Move the platform to get the fork holes in alignment with the forks of the forklift. Adjust the forks until they match the fork holes.
- 1.4 Move the forklift to insert the forks into the fork holes. Fix the lever at the back of the platform.
- 1.5 Reeve the chain through the bracket of forklift and fix the other end of the chain on the platform.
- 1.6 Open the left or right door and equip the accessory. Put tools and devices into the platform and accessory. Then platform operator can enter the platform and closed the door.
- 1.7 Check all the points that need to be fixed. Fix it if any hasn't been fixed.
- 1.8 Platform operator must check and wear the safety belt.
- 1.9 Others keep away from the platform. Forklift driver move the truck to the appointed working place and lift the platform to the needed height. All controls should be locked except the lifting lever. The driver should not leave the forklift.
- 1.10 When the work is finished, platform operator informs the forklift driver to lower the

Product Description

platform to the ground. Then the operator can take off the safety belt, accessory, tools and devices and open the door to get out. The forklift driver draws back forks from the platform. Finally, fold the platform according to the opposite steps of installation above.

4 Attention

- 2.1 Operators of platform and forklift must be trained or authorized.
- 2.2 Illumination of working place: illumination intensity shouldn't be less than 500lx according to the illumination standard of CIE.
- 2.3 Make sure there are no cables, steel rods, concrete pipe or other protrusions within the space where the platform lifts.
- 2.4 It is prohibited for anyone to stand or pass under the platform.
- 2.5 Platform operator must work according to the installation instructions above.
- 2.6 Check the forklift of performance before use to ensure the safety.
- 2.7 When the platform is lifted, it is prohibited to move the forklift forwards or backwards unless the safety is ensured and both platform operator and company safety director agree to.

5 EXPLODED VIEW & PART LIST

Item	Description	Qty	Notes
1	Base Frame	1	
2	Handrail frame	1	
3	Safety guard Frame	1	
4	Lock Pin	1	
5	Plain Washer 10	16	
6	Spring Washer 10	16	
7	Bolt M10x10	16	
8	Lock Nut M10	16	
9	Castor unit	4	
10	Lock lever with chain	2	

Product Description

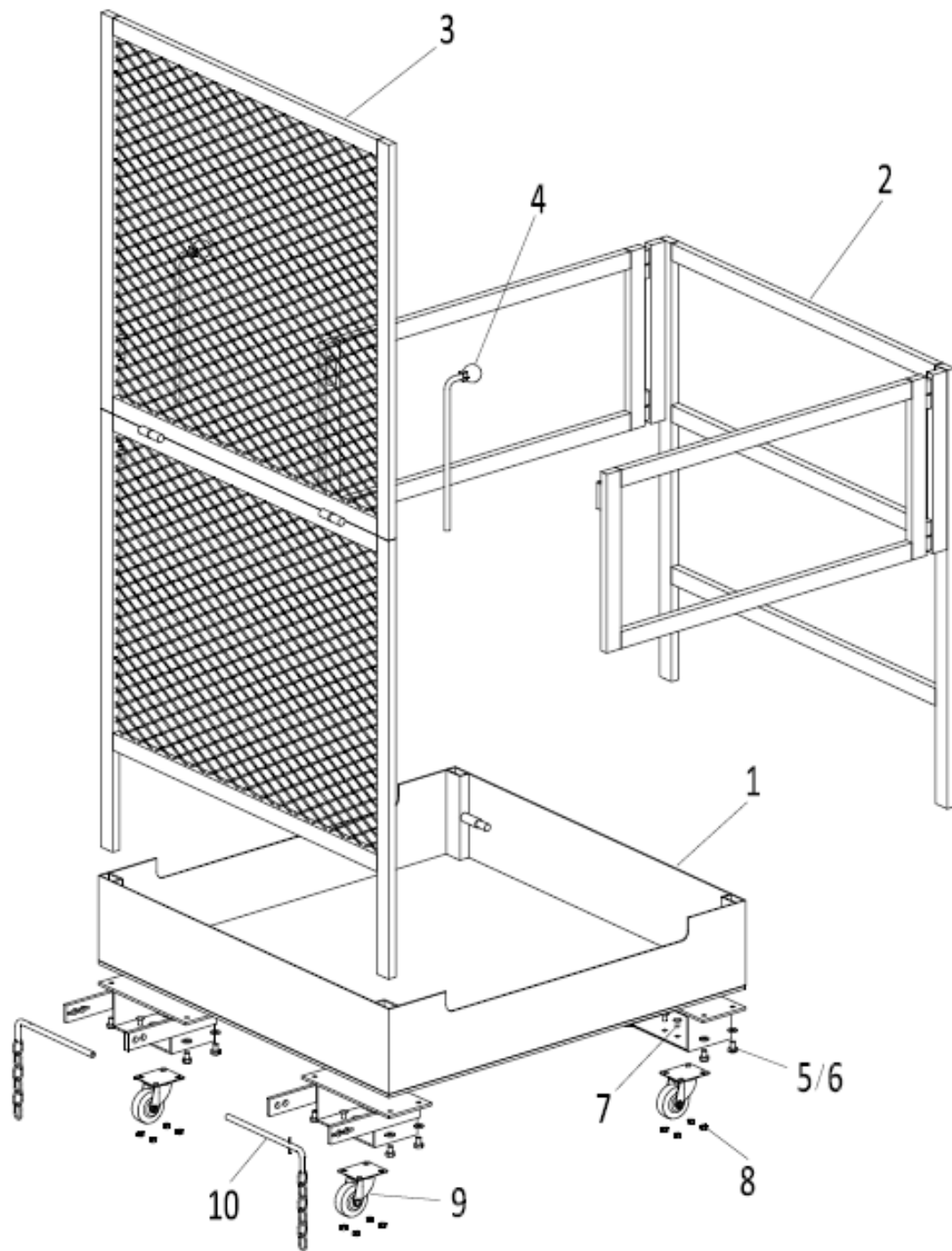

Product Description

6 Folding Process

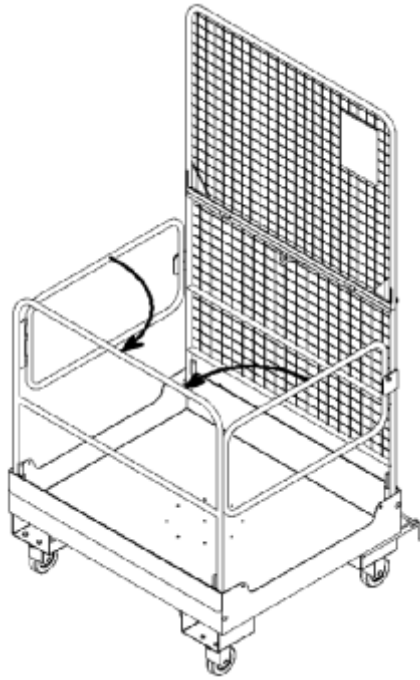

Fig.1

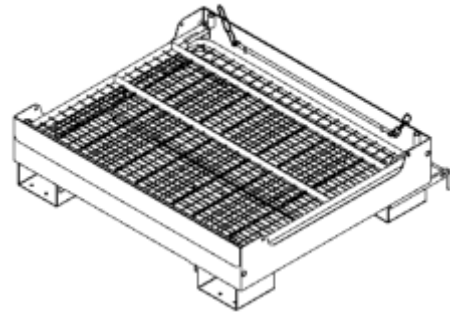

Fig.5

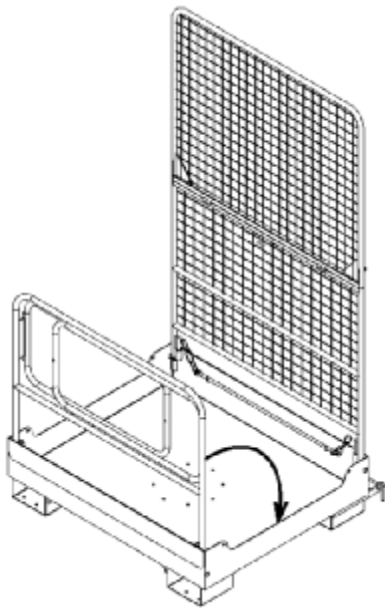

Fig.2

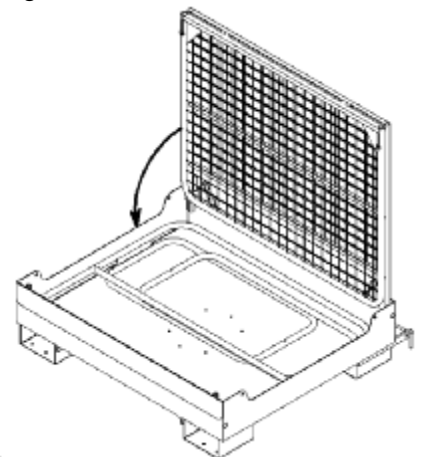

Fig.4

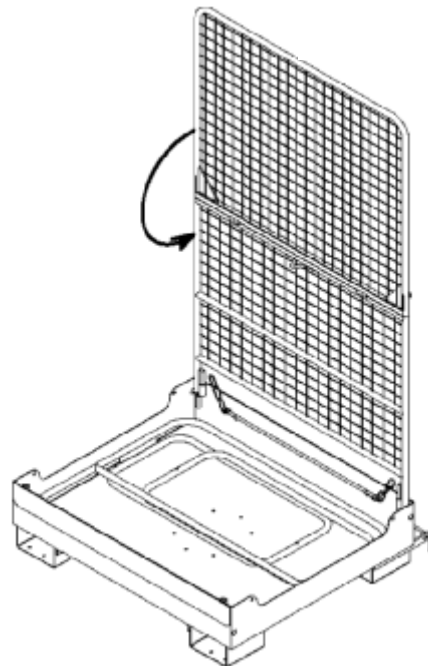

Fig.3