

User Manual

Manual de Usuario

Manuel de l'Utilisateur

Customer Service  
US: 1-800-645-2986

Servicio de atención al Cliente  
US: 1-800-645-2986

Service à la clientèle  
Canada: 888-645-2986

# Deluxe Industrial Pedestal Fan

Model: 292593

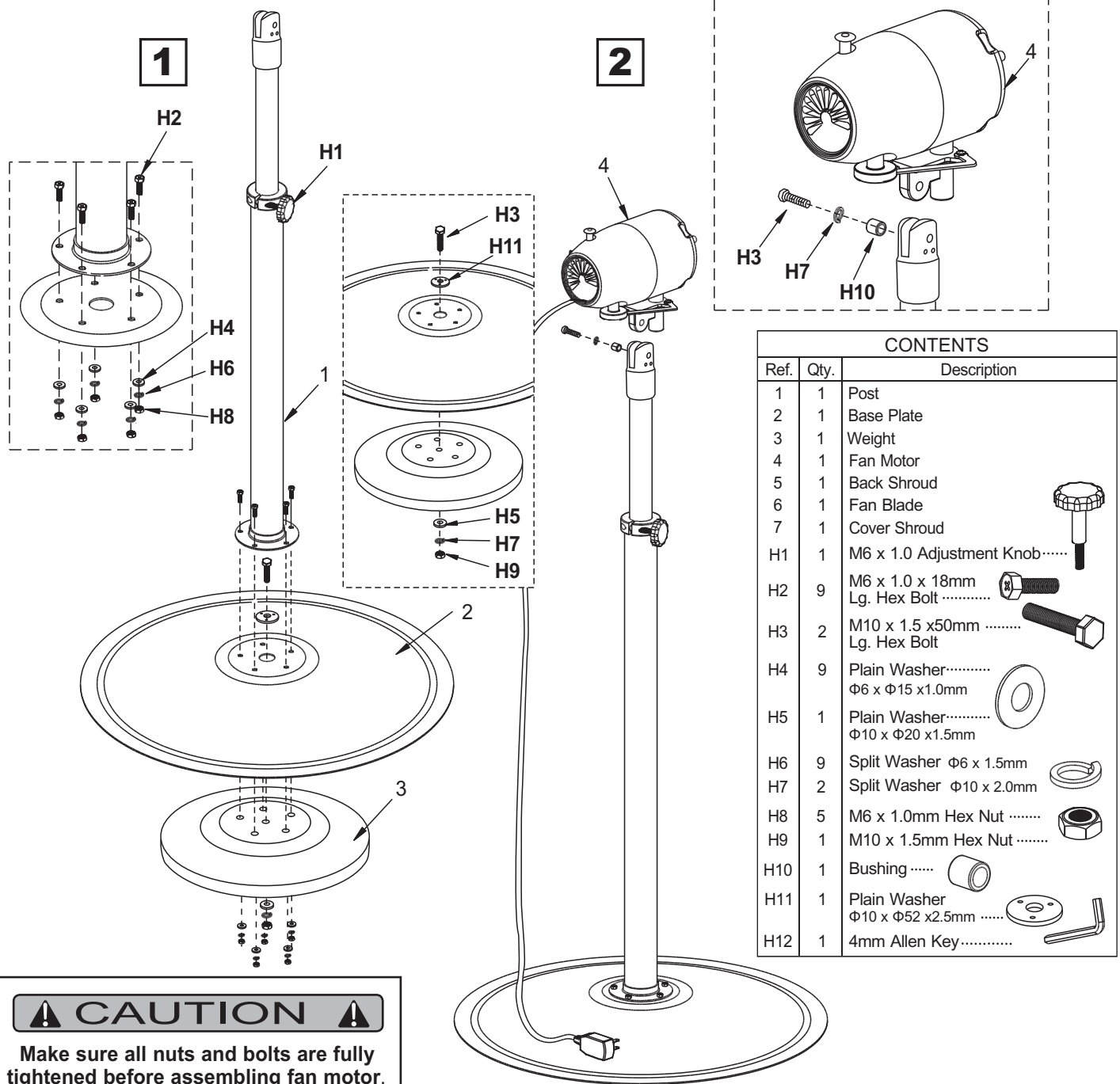

CONTENTS		
Ref.	Qty.	Description
1	1	Post
2	1	Base Plate
3	1	Weight
4	1	Fan Motor
5	1	Back Shroud
6	1	Fan Blade
7	1	Cover Shroud
H1	1	M6 x 1.0 Adjustment Knob.....
H2	9	M6 x 1.0 x 18mm Lg. Hex Bolt .....
H3	2	M10 x 1.5 x50mm ..... Lg. Hex Bolt
H4	9	Plain Washer..... Φ6 x Φ15 x1.0mm
H5	1	Plain Washer..... Φ10 x Φ20 x1.5mm
H6	9	Split Washer Φ6 x 1.5mm
H7	2	Split Washer Φ10 x 2.0mm
H8	5	M6 x 1.0mm Hex Nut .....
H9	1	M10 x 1.5mm Hex Nut .....
H10	1	Bushing .....
H11	1	Plain Washer Φ10 x Φ52 x2.5mm .....
H12	1	4mm Allen Key.....

# Deluxe Industrial Pedestal Fan

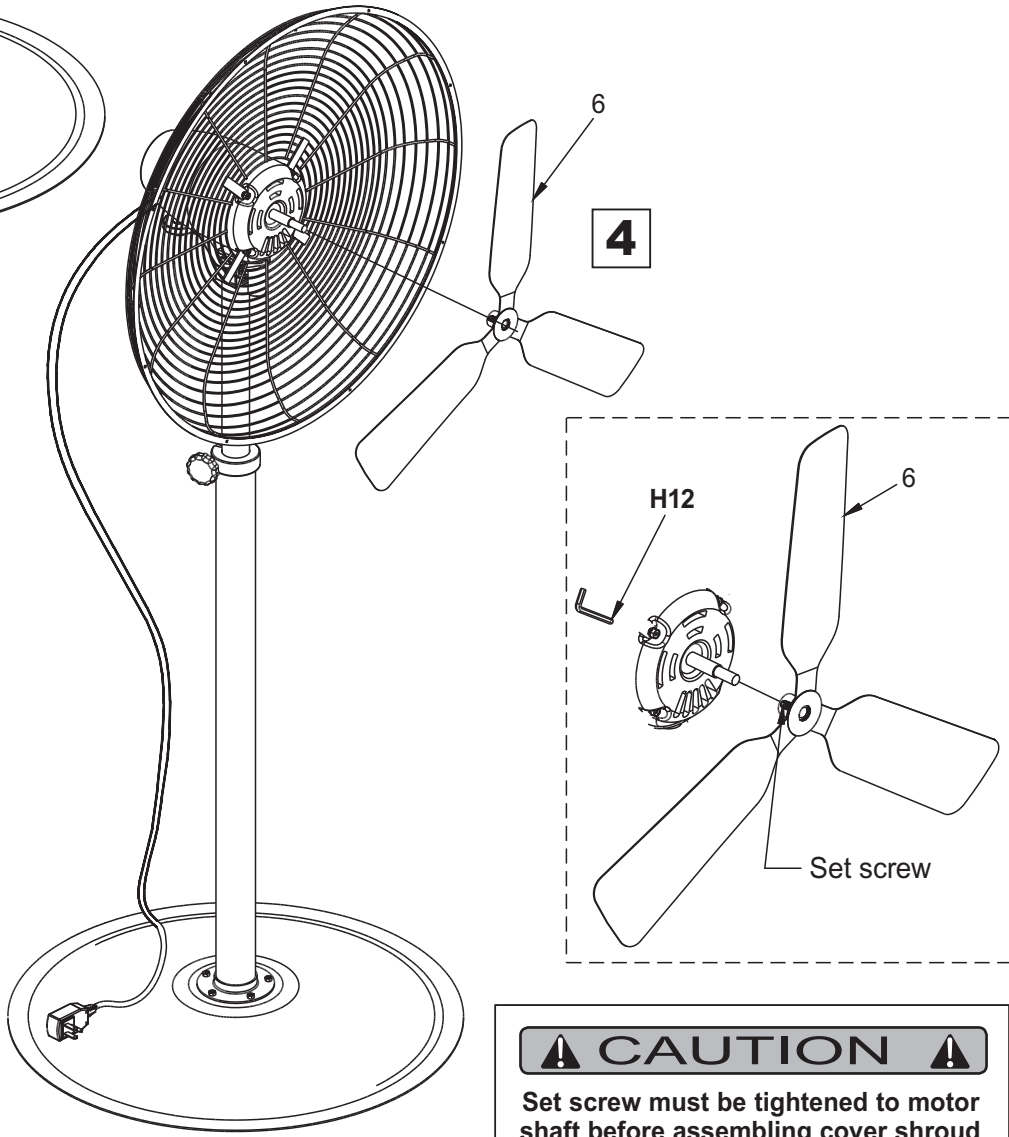
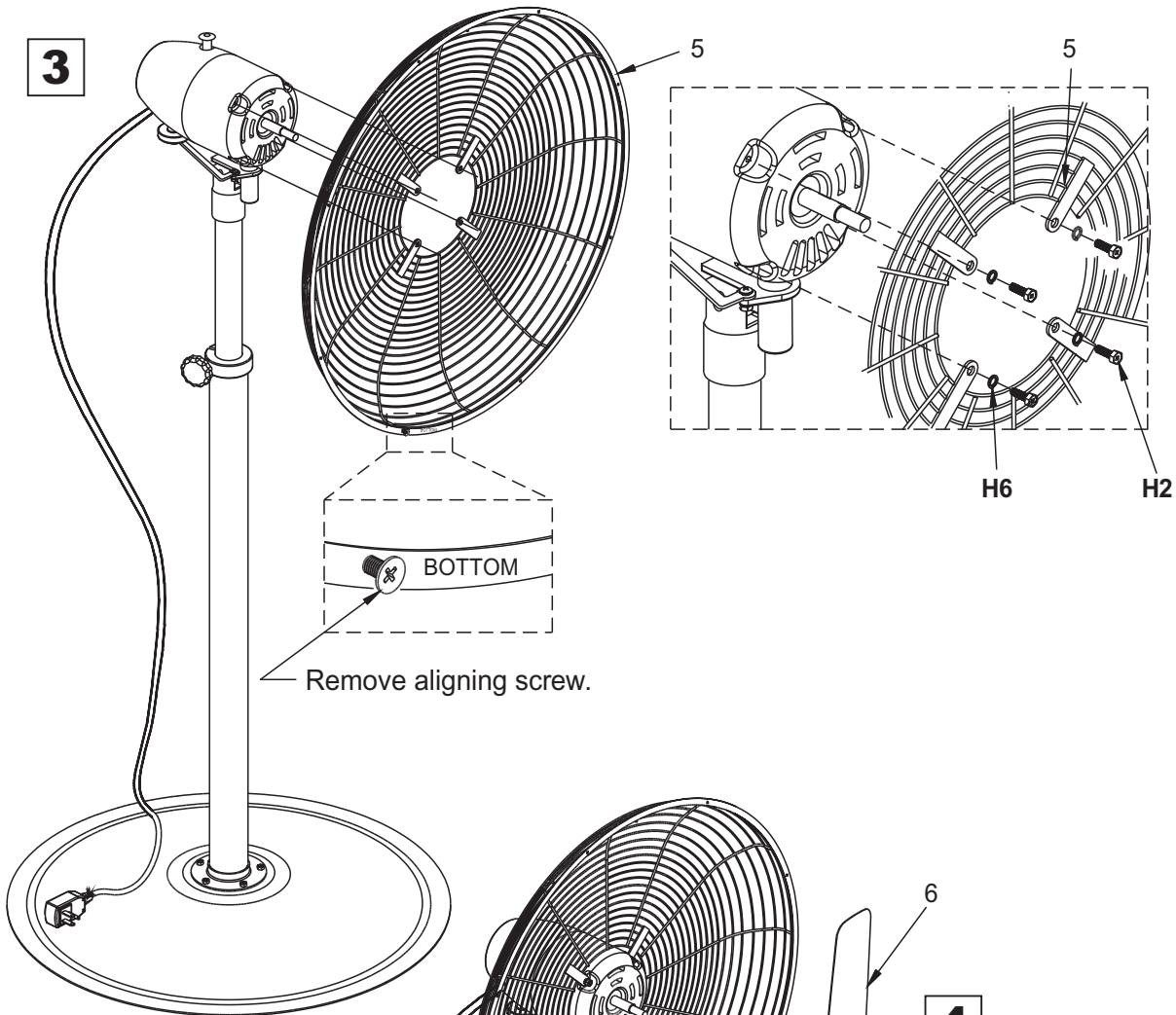

**⚠ CAUTION ⚠**  
 Set screw must be tightened to motor shaft before assembling cover shroud.

# Deluxe Industrial Pedestal Fan

5

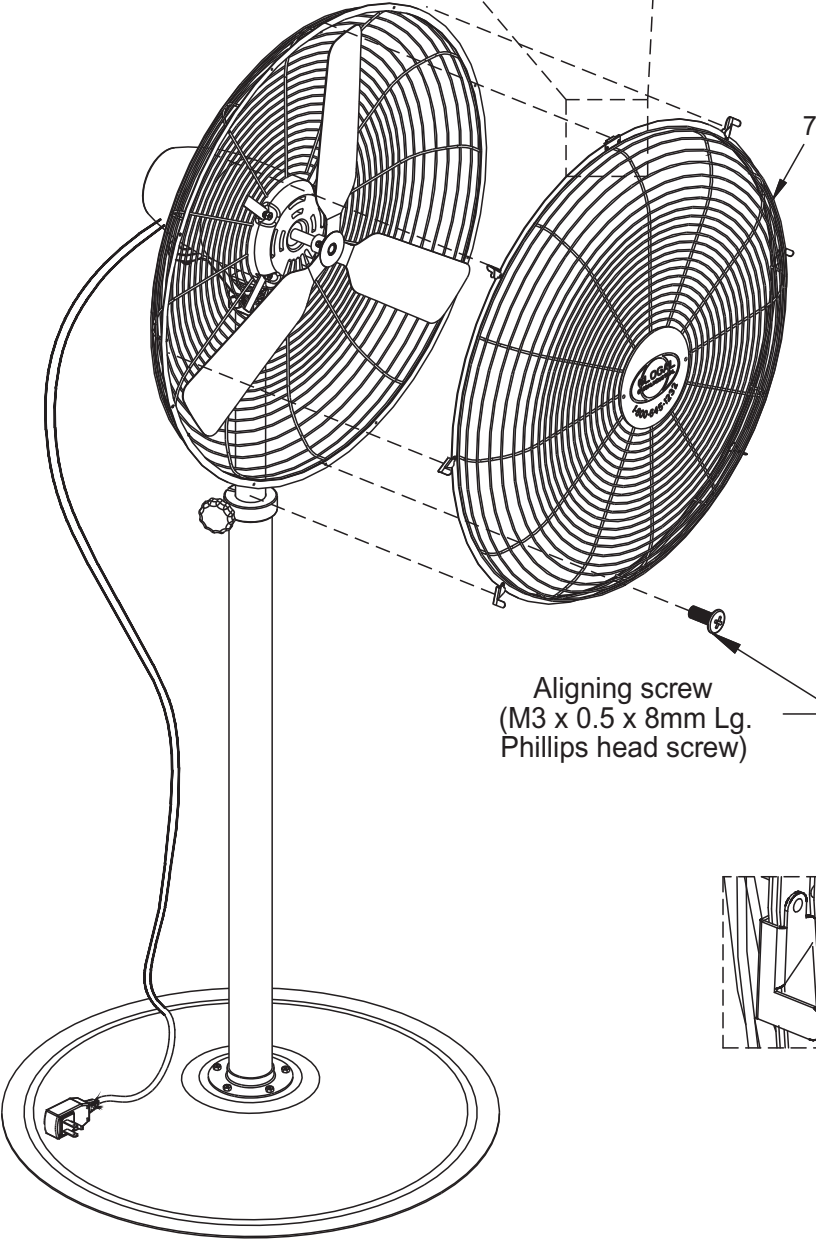
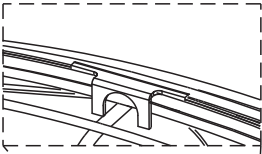

Aligning screw  
(M3 x 0.5 x 8mm Lg.  
Phillips head screw)



6

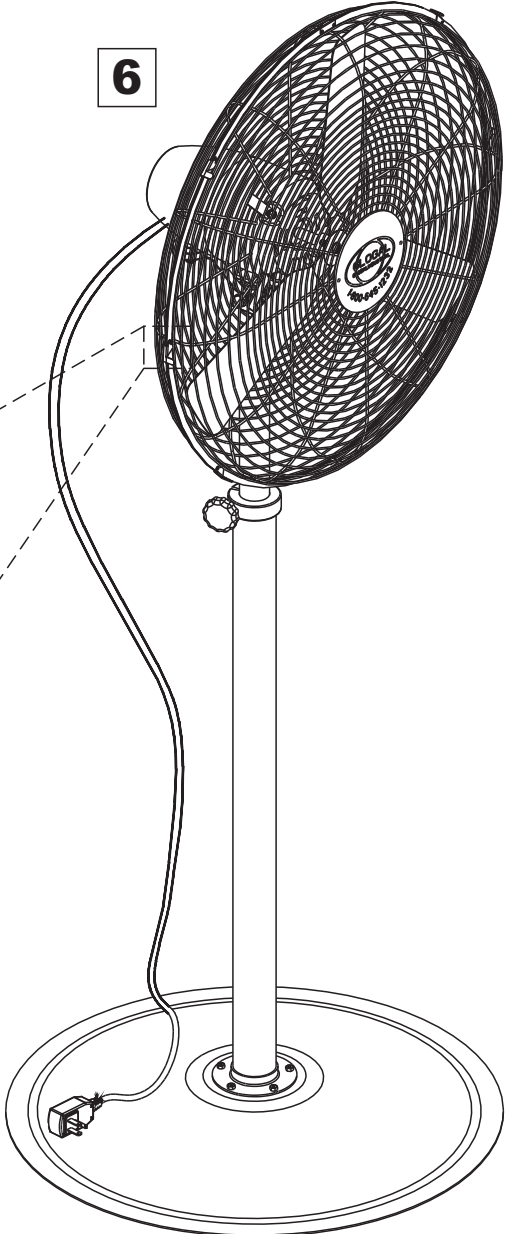

**CAUTION**

Unplug prior to adjusting.

**7**

Oscillation selector

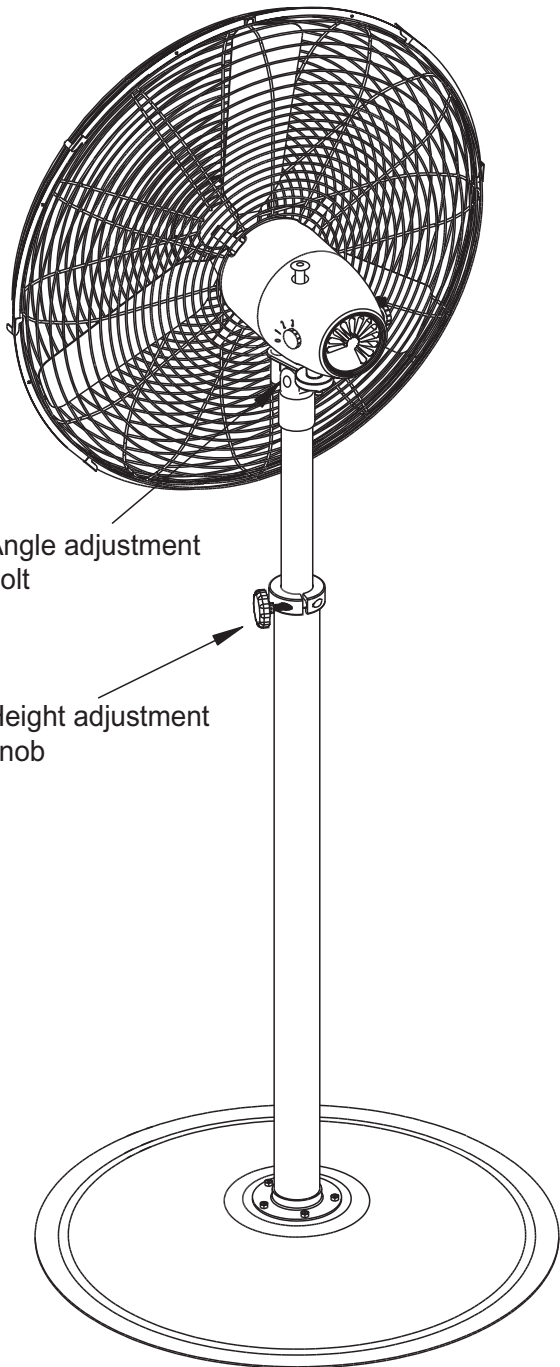

Angle adjustment bolt

Height adjustment knob

## TO OSCILLATE

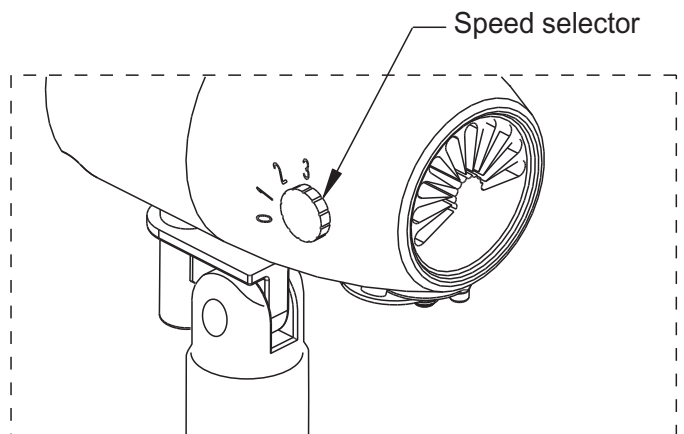
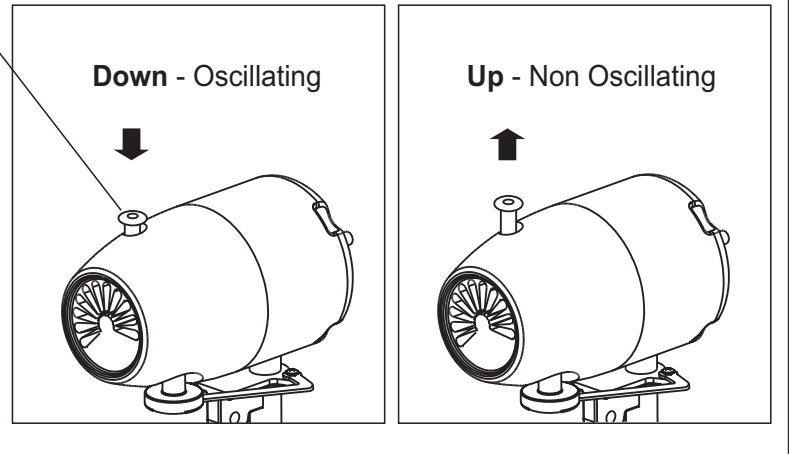

Speed selector

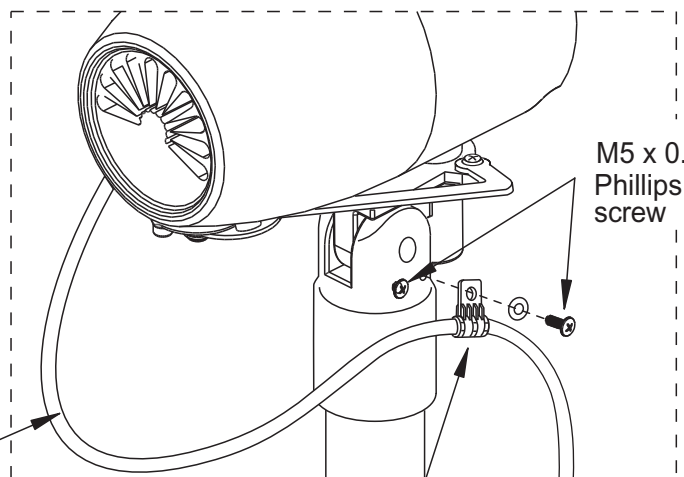

M5 x 0.8 x 8mm  
Phillips pan head  
screw

Power cord

Power cord clamp

User Manual

Manual de Usuario

Manuel de l'Utilisateur

Customer Service  
US: 1-800-645-2986

Servicio de atención al Cliente  
US: 1-800-645-2986

Service à la clientèle  
Canada: 888-645-2986

# Ventilador de pie industrial delux

Modelo: 292593

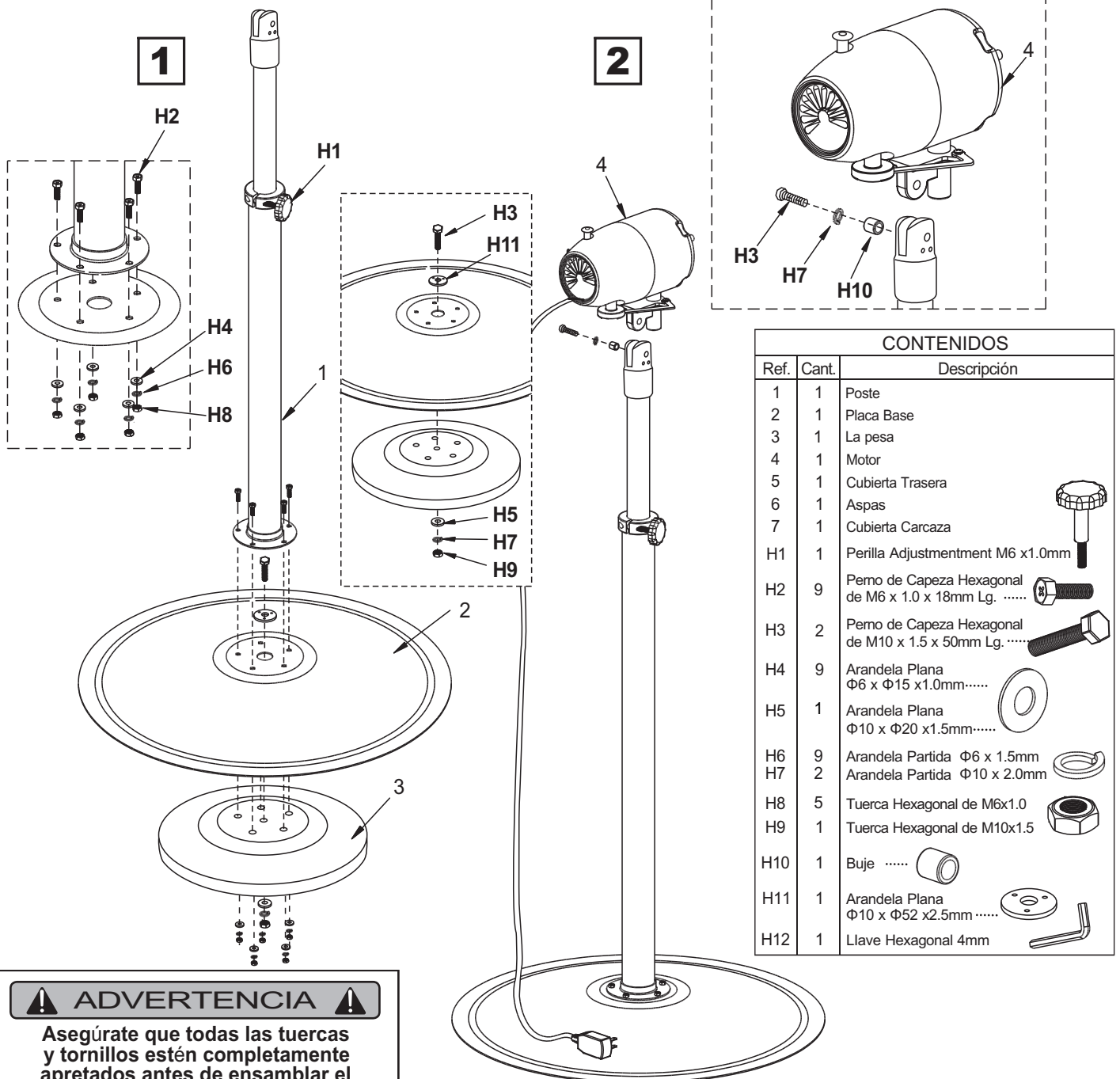

## CONTENIDOS

Ref.	Cant.	Descripción
1	1	Poste
2	1	Placa Base
3	1	La pesa
4	1	Motor
5	1	Cubierta Trasera
6	1	Aspas
7	1	Cubierta Carcasa
H1	1	Perilla Adjustment M6 x1.0mm
H2	9	Perno de Cabeza Hexagonal de M6 x 1.0 x 18mm Lg. ....
H3	2	Perno de Cabeza Hexagonal de M10 x 1.5 x 50mm Lg. ....
H4	9	Arandela Plana $\Phi 6 \times \Phi 15 \times 1.0\text{mm}$ .....
H5	1	Arandela Plana $\Phi 10 \times \Phi 20 \times 1.5\text{mm}$ .....
H6	9	Arandela Partida $\Phi 6 \times 1.5\text{mm}$
H7	2	Arandela Partida $\Phi 10 \times 2.0\text{mm}$
H8	5	Tuerca Hexagonal de M6x1.0
H9	1	Tuerca Hexagonal de M10x1.5
H10	1	Buje .....
H11	1	Arandela Plana $\Phi 10 \times \Phi 52 \times 2.5\text{mm}$ .....
H12	1	Llave Hexagonal 4mm

### ⚠ ADVERTENCIA ⚠

Asegúrate que todas las tuercas y tornillos estén completamente apretados antes de ensamblar el motor del ventilador.



# Ventilador de pie industrial deluxe

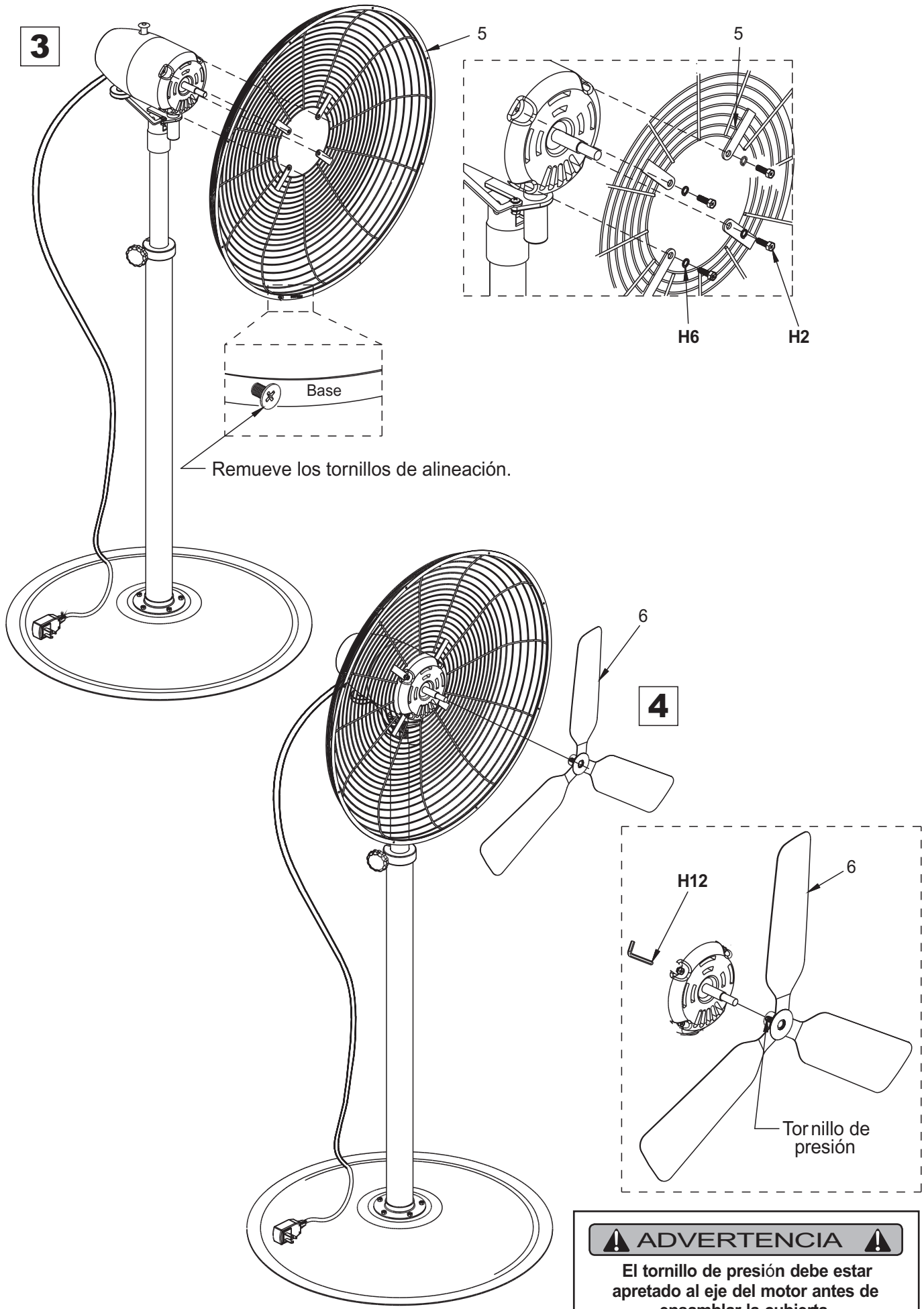

**⚠ ADVERTENCIA ⚠**  
 El tornillo de presión debe estar apretado al eje del motor antes de ensamblar la cubierta.

# Ventilador de pie industrial deluxe

5

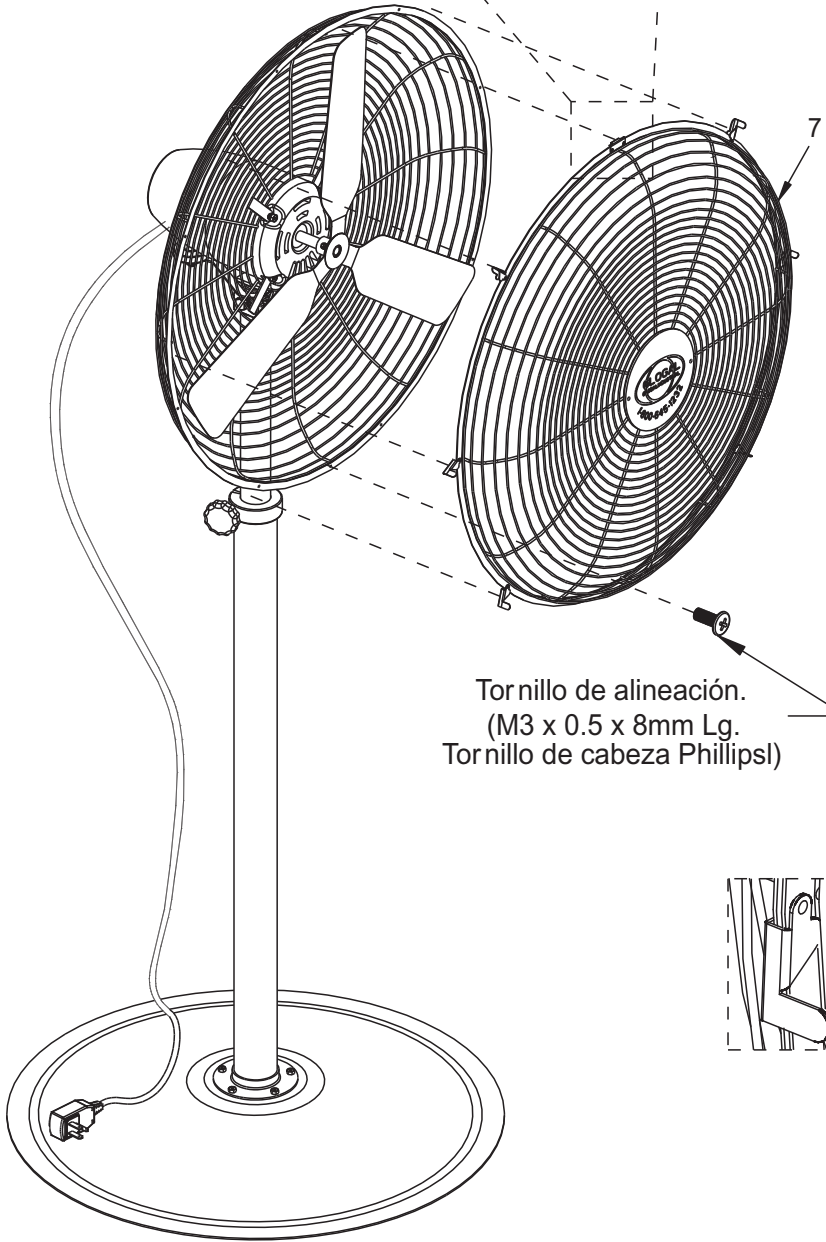
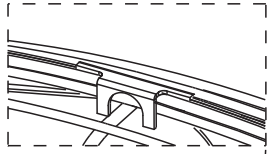

Tornillo de alineación.  
(M3 x 0.5 x 8mm Lg.  
Tornillo de cabeza Phillips!)

6

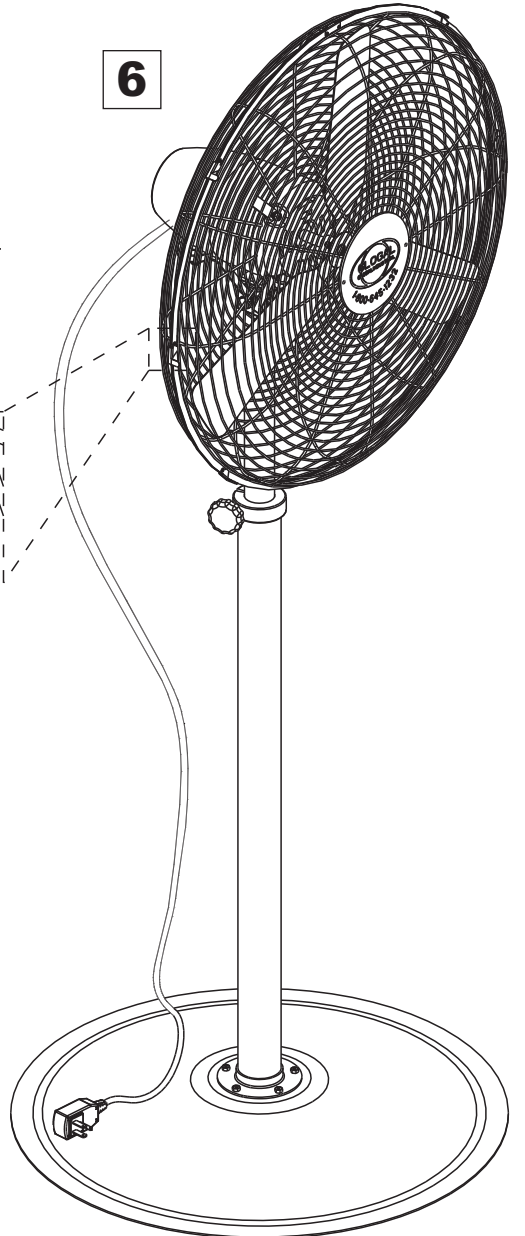

# Ventilador de pie industrial delux

**⚠ ADVERTENCIA ⚠**  
Retire antes de ajustar.

**7**

Selección de Oscilación

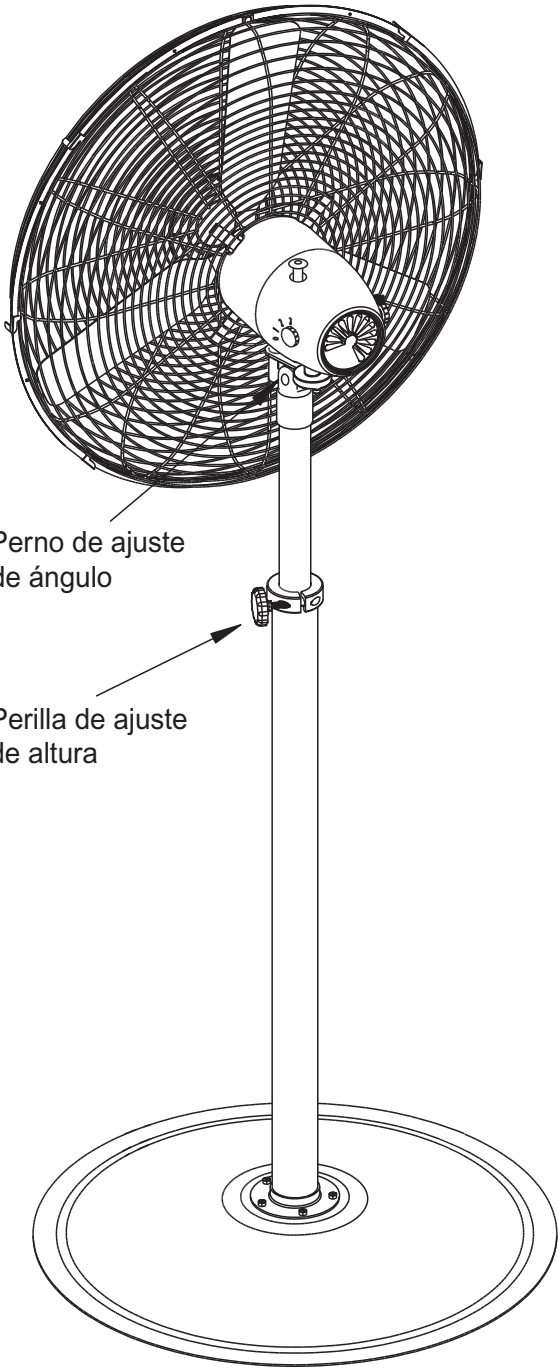

Perno de ajuste de ángulo

Perilla de ajuste de altura

### PARA OSCILAR

<p><b>Abajo – oscilante</b></p>	<p><b>Arriba – no oscilante</b></p>
---------------------------------	-------------------------------------

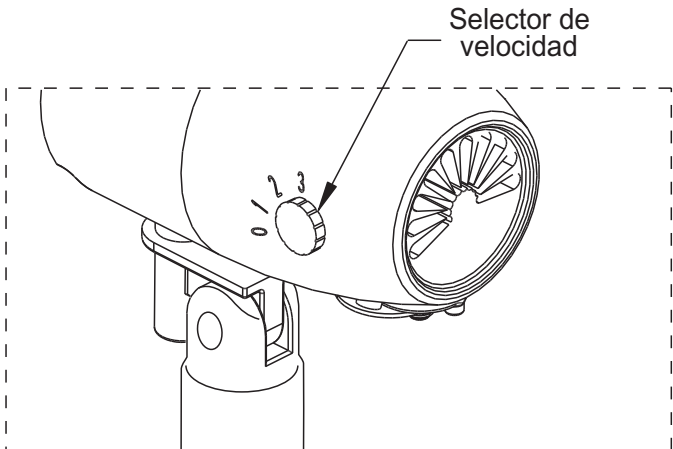

Selector de velocidad

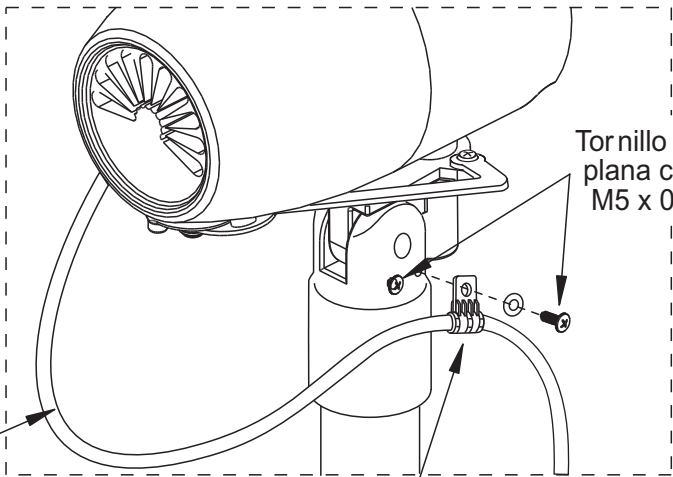

Cable de alimentación

Abrazadera del cable de alimentación

Tornillo de cabeza plana con ranura M5 x 0.8 x 8mm



User Manual

Manual de Usuario

Manuel de l'Utilisateur

Customer Service  
US: 1-800-645-2986

Servicio de atención al Cliente  
US: 1-800-645-2986

Service à la clientèle  
Canada: 888-645-2986

# Ventilateur industriel de luxe sur pied

Modèle: 292593

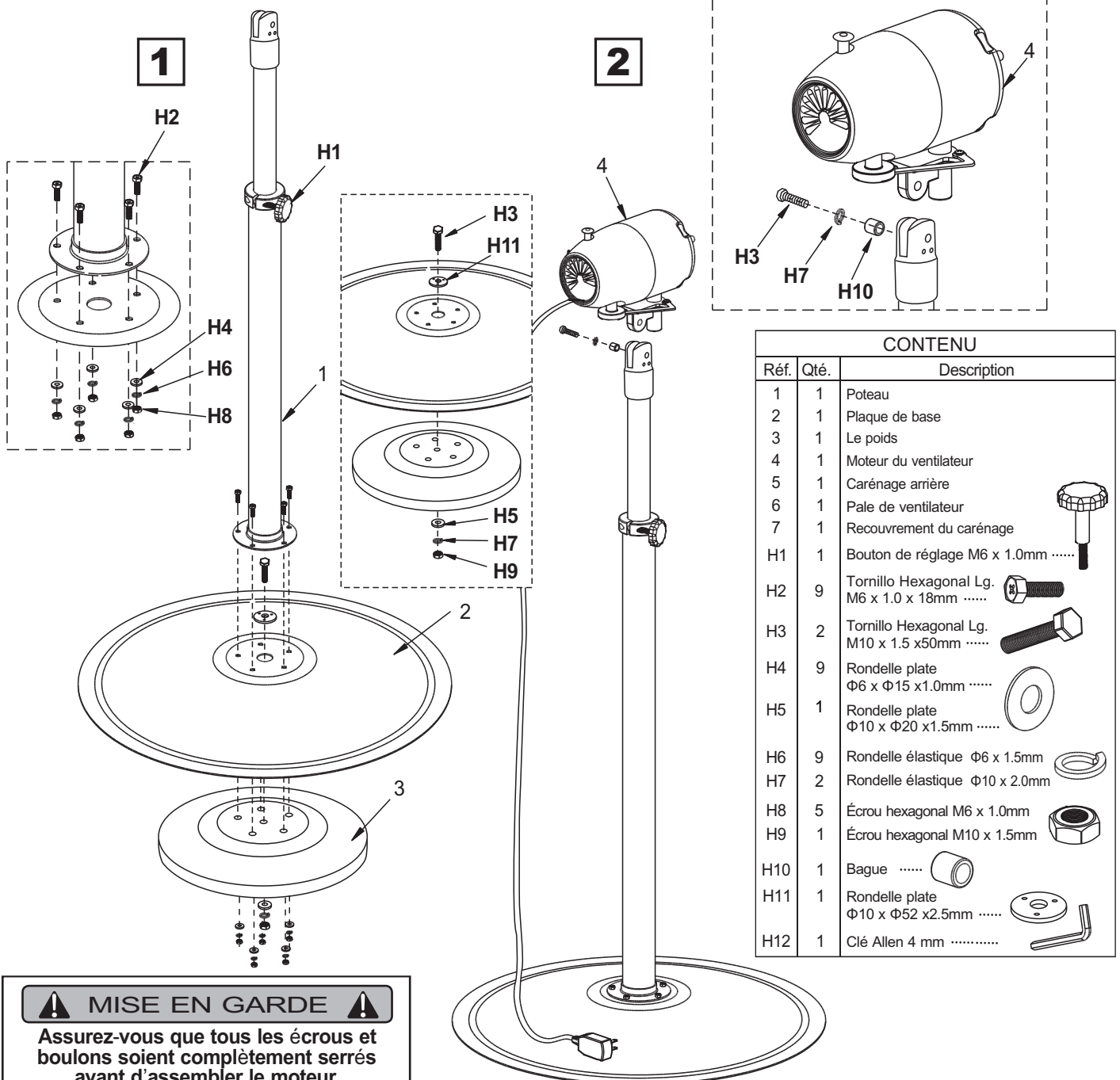

CONTENU		
Réf.	Qté.	Description
1	1	Poteau
2	1	Plaque de base
3	1	Le poids
4	1	Moteur du ventilateur
5	1	Carénage arrière
6	1	Pale de ventilateur
7	1	Recouvrement du carénage
H1	1	Bouton de réglage M6 x 1.0mm .....
H2	9	Tornillo Hexagonal Lg. M6 x 1.0 x 18mm .....
H3	2	Tornillo Hexagonal Lg. M10 x 1.5 x50mm .....
H4	9	Rondelle plate Φ6 x Φ15 x1.0mm .....
H5	1	Rondelle plate Φ10 x Φ20 x1.5mm .....
H6	9	Rondelle élastique Φ6 x 1.5mm
H7	2	Rondelle élastique Φ10 x 2.0mm
H8	5	Écrou hexagonal M6 x 1.0mm
H9	1	Écrou hexagonal M10 x 1.5mm
H10	1	Bague .....
H11	1	Rondelle plate Φ10 x Φ52 x2.5mm .....
H12	1	Clé Allen 4 mm .....

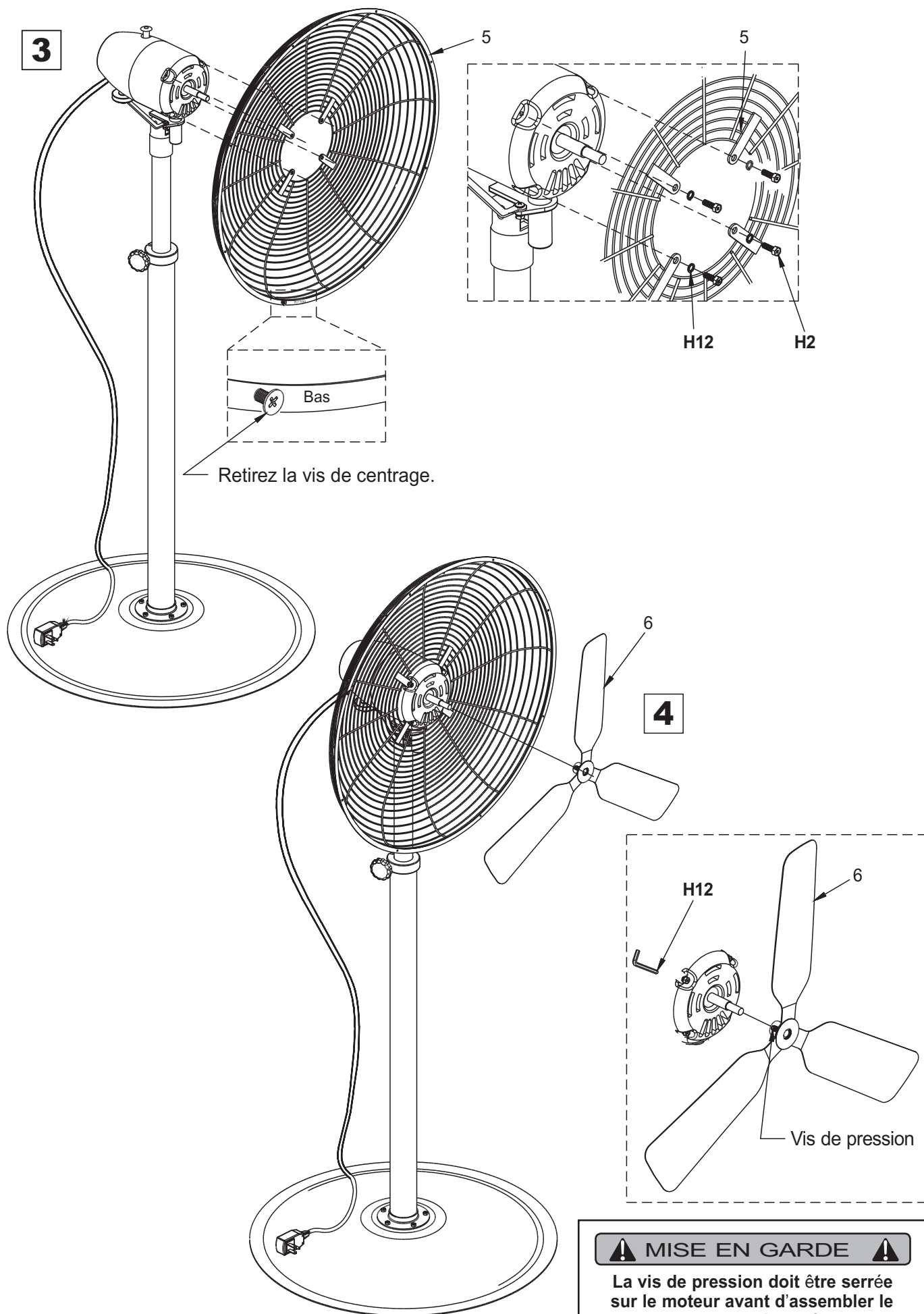

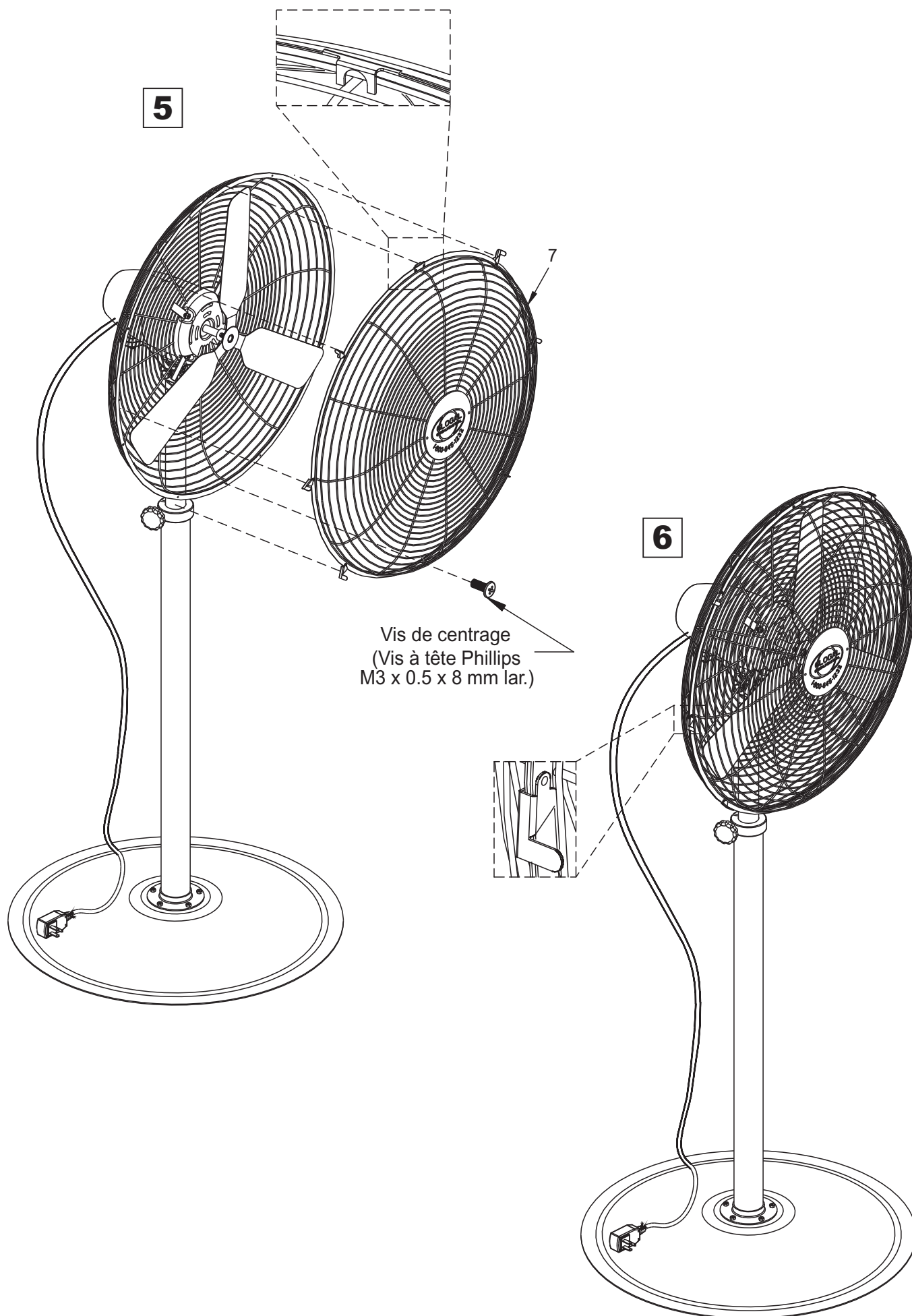

**⚠ MISE EN GARDE ⚠**  
Débranchez avant l'ajustement.

**7**

Le selecteur d'oscillation

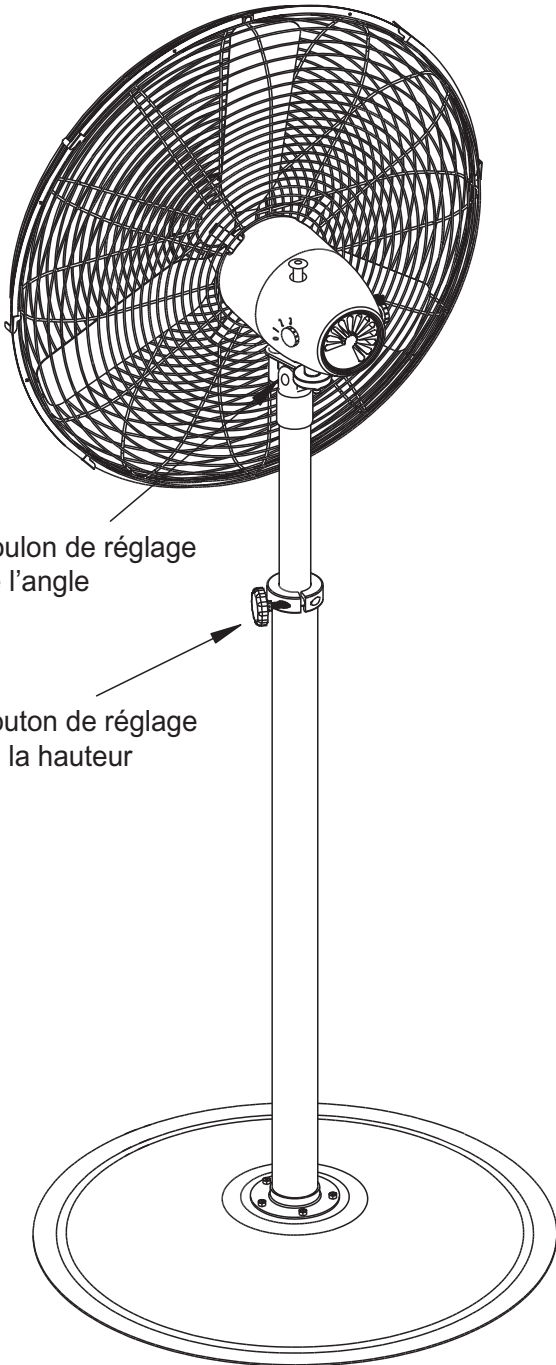

Boulon de réglage  
de l'angle

Bouton de réglage  
de la hauteur

## POUR OSCILLER

Oscillant vers le bas

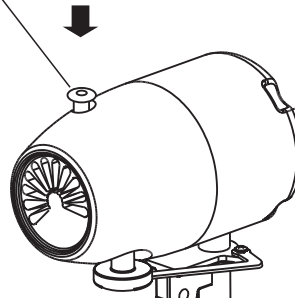

Haut et non oscillant

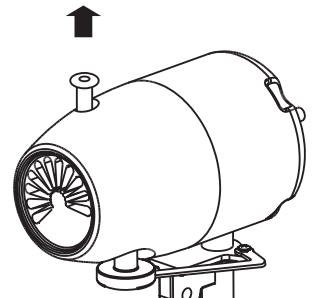

Sélecteur de  
vitesse

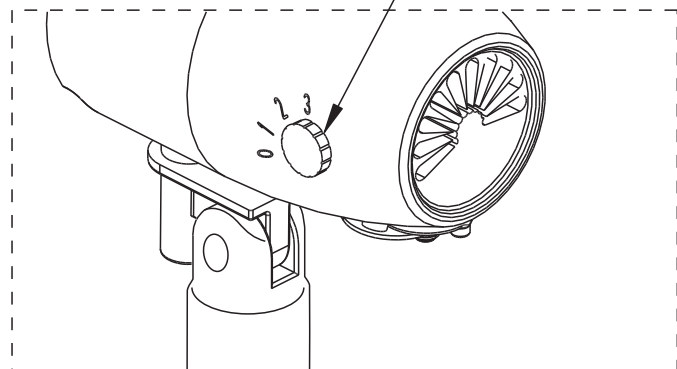

Vis à tête cylindrique  
Phillips M5 x 0.8 x 8 mm

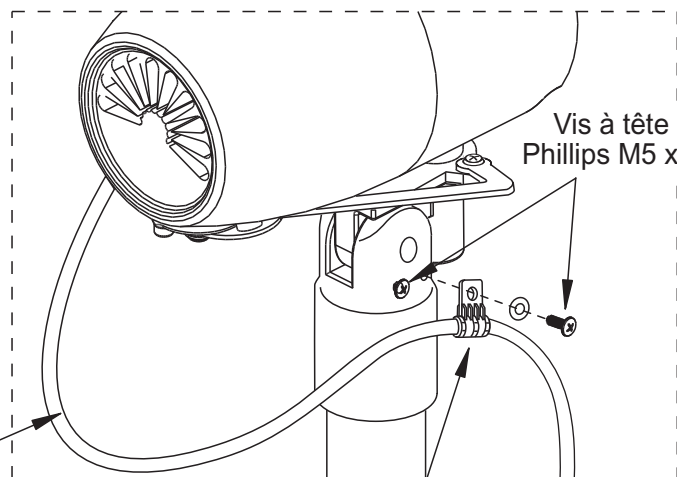

Cordon  
d'alimentation

Pince du cordon d'alimentation