



**GLOBAL  
INDUSTRIAL™**

**Assembly Instructions**

Customer Service  
US: 1-800-645-2986

**Instrucciones de Ensamblaje**

Servicio de atención al Cliente  
US: 1-800-645-2986

**Directives d'assemblage**

Service à la clientèle  
Canada: 888-645-2986

# POWERED PALLET TRUCK MODEL 989069

**FOR OPERATION SAFETY**, please read and understand instructions carefully prior to assembling, installing, operating, or performing maintenance on the product. Be sure to observe all safety information. Failure to comply with instructions could result in personal injury and/or property damage. Retain instructions for future reference.

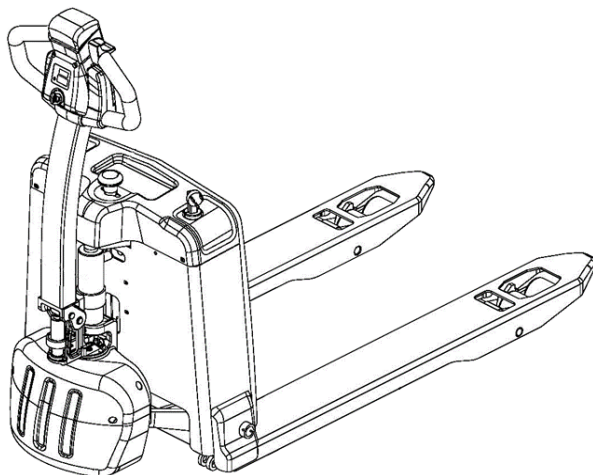

# **WARNING**

**Do not operate this truck unless you have:**

Been authorized and trained to do so.

Have read all warnings and instructions in operator manual and on this truck.

**Do not operate this truck until you have:**

Checked its condition. Give special attention to tires, horn, battery, controller, lift system, brakes, steering mechanism, guards and safety devices.

Operate truck only from designated operating position. Do not carry passengers. Keep feet clear of truck and wear foot protection.

Observe applicable traffic regulations. Yield right of way to pedestrians. Slow down and sound horn at cross aisles and wherever vision is obstructed.

Start, stop, travel, steer and brake smoothly. Slow down for turns and on uneven or slippery surfaces that could cause truck to slide or overturn. Use special care when traveling without load as the risk of overturn may be greater.

Always look in the direction of travel. Keep a clear view, and when load interferes with visibility, travel with load trailing.

Take special care when operating on ramps - travel slowly, and do not travel in an angle or make turns. Travel with forks facing downhill.

Do not overload truck. Check nameplate for capacity and load center information.

Do not handle loads which are higher than the load backrest or load backrest extension unless load is secured so that no part of it could fall backward. Before lifting, make sure the load is centered, forks are completely under load, and load is as far back as possible against load backrest.

When leaving the truck, neutralize travel control, fully lower the forks and set brake. When leaving truck unattended, also shut off power.

## **PROPOSITION 65**



### **WARNING**

In accordance to

**California Health & Safety Code Sections 25249.5 et. seq.**

this warning is to let you know that this product can expose you to chemicals known to the state of California to cause cancer, birth defects and other reproductive harm.

For more information visit: [www.p65warnings.ca.gov](http://www.p65warnings.ca.gov)

# FOREWORD

As a lift truck operator, you are responsible for a machine that is useful, powerful, and can be hazardous if not operated as described. Your Global Industrial truck may weigh more than some cars, depending on the model. Observing and practicing the safety warnings in this manual cannot be overemphasized. Just knowing the warnings, however, is no substitute for common sense. Focusing on the task at hand will, in almost all cases, prevent accidents. Think of the truck as your own. In this way you will learn its capabilities and limitations.

This manual is intended to remain with the truck at all times as a handy reference guide to operation. Detailed maintenance procedures are found in the service manual for the specific truck model, and are to be performed only by a qualified technician. For further information on obtaining a complete parts and service manual, see [page 23](#) of this manual.

The operator who knows his truck will learn to spot problems as they develop. This is accomplished by performing the Daily Checks and reporting any problems to the designated authority.

## TABLE OF CONTENTS

<b>SAFETY SYMBOLS</b> .....	<b>4</b>
<b>GENERAL DESCRIPTION</b> .....	<b>4</b>
<b>NAME PLATE AND WARNING DECAL</b> .....	<b>4</b>
<b>LOAD CAPACITY</b> .....	<b>7</b>
<b>BEFORE OPERATION</b> .....	<b>8</b>
<b>INSTRUMENTS AND CONTROLS</b> .....	<b>11</b>
<b>Display Unit</b> .....	<b>11</b>
<b>Low Voltage Protection</b> .....	<b>11</b>
<b>OPERATION</b> .....	<b>12</b>
<b>Driving Instructions</b> .....	<b>12</b>
<b>Steering</b> .....	<b>13</b>
<b>Stopping</b> .....	<b>13</b>
<b>Parking</b> .....	<b>13</b>
<b>Load Handling</b> .....	<b>13</b>
<b>Moving a Disabled Truck</b> .....	<b>14</b>
<b>Battery Charging</b> .....	<b>14</b>
<b>NOTICE - OBTAINING A PARTS AND SERVICE MANUAL</b> .....	<b>23</b>

## SAFETY SYMBOLS

**WARNING** and **CAUTION** are both signal words intended to alert the viewer to the existence and relative degree of a hazard. They are both preceded by a safety alert symbol consisting of an exclamation mark enclosed by a triangle.



A **Warning** indicates a hazard which could result in injury or death if proper precautions are not taken.

A **Caution** indicates a reminder of routine safety practices.

A prohibition slash (circle with diagonal slash through it) indicates a procedure or action that should **not** be performed under any circumstances, as both personal injury and/or damage to equipment will result.



## GENERAL DESCRIPTION

Global Industrial Pallet trucks lift and transport loads on rigid forks.

Control for steering, braking, forward and reverse travel, horn, lift, lower and speed control are all located on the control handle.

Trucks in this series may vary in load capacity, battery arrangement, and instrumentation, depending on model and options.

## NAME PLATE AND WARNING DECAL

Name plate and warning decal locations may vary between models, but they are always near the steering arm within sight of the operator.

If the name plate or warning decal are lost or damaged they should be replaced immediately. Have your supervisor or the designated authority contact Global Industrial Authorized Dealer for replacement.

The name plate shows the model number, serial number, and truck type. Battery type, with voltage and minimum weight, is shown along with information on the load capacity and load center.

The warning decal contains warnings which also appear, with illustrations, in the Operating Precautions section of this manual.

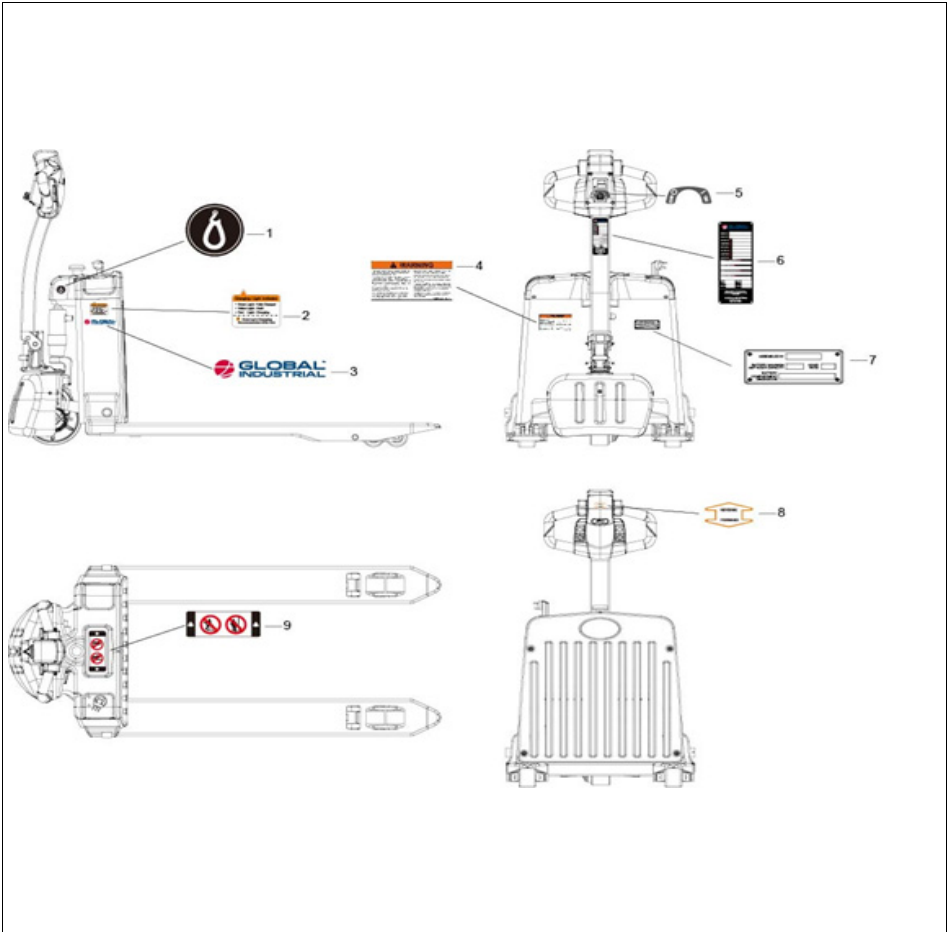

**989069 Name Plate and Warning Decal Locations - Typical**

ITEM	COMPONENT	ITEM	COMPONENT
1	Lifting Label	6	Name Plate
2	Charging Light Indicator	7	Name Plate - UL Battery Info.
3	Global Logo	8	Forward - Reverse Label
4	Warning Label	9	No "Riding" Label
5	Key Label		

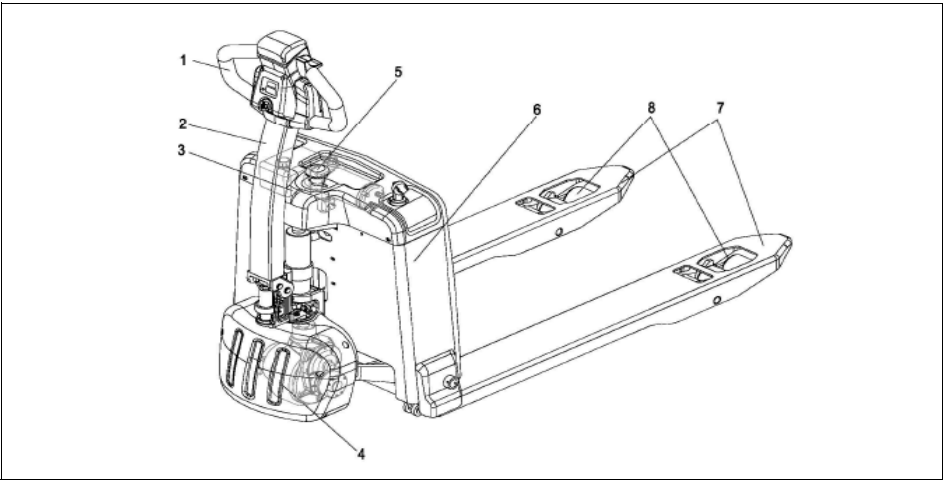

**Truck Overview**

ITEM	COMPONENT	ITEM	COMPONENT
1	Control Handle	5	Emergency Stop Switch
2	Control Arm	6	Frame
3	Lift Cylinder	7	Forks
4	Drive Assembly	8	Load Wheels



**WARNING:**

This truck is equipped with a battery. Read and heed the following warning plus any other warnings located near or on the battery.

<p><b>BATTERY HAZARD</b></p>	<p><b>! DANGER</b></p> <p><b>EXPLOSIVE/POISON/CAUSTIC</b>  <b>NO SPARKS, FLAMES, SMOKING</b>  <b>BATTERY ACID</b> can cause blindness  and severe burns  <b>SHIELD EYES, AVOID SKIN CONTACT</b>  <b>IF SPLASHED</b> flush immediately with water,  get medical help fast.</p> <p>Do not service battery while on charge.  Do not connect or disconnect battery from  charger while charger is on.</p> <p>Only qualified and experienced personnel should  perform maintenance and repair on batteries.  Use caution while servicing or removing battery.  (Refer to Battery Safety Sheet).</p>
------------------------------	--

# LOAD CAPACITY

Do not overload truck. Check name plate for load weight capacity and load center information.

The load capacity depends on the load center. The load maximum capacity listed on the capacity plate assumes a uniform load whose center is at 1/2 the length of the fork and centered between the forks. The maximum load capacity is reduced when the load center exceeds 1/2 the length of the forks or is not centered between the forks. The fork length and wheel-base must be adequate for the skid or bin to be handled.

Note that a truck undergoing speed changes is less stable than a standing truck. If you are not sure that the truck can lift a certain load, consult your supervisor or the designated authority.

	
MODEL NO.	<input type="text"/>
SERIAL NO.	<input type="text"/>
MAX CAP LB/KG	<input type="text"/>
LOAD CTR IN/MM	<input type="text"/>
LIFT HGT IN/MM	<input type="text"/>
ALT CAP LB/KG	<input type="text"/>
LOAD CTR IN/MM	<input type="text"/>
LIFT HGT IN/MM	<input type="text"/>
TRUCK WT LESS BATTERY LB/KG	
<input type="text"/>	
BATTERY MIN WT LB/KG	
<input type="text"/>	
TRUCK WT WITH BATTERY LB/KG	
<input type="text"/>	
BATTERY MAX WT LB/KG	
<input type="text"/>	
TRUCK TYPE	<input type="text"/>
BATTERY TYPE	<input type="text"/>
CERTIFIED	<input type="text"/>
VOLTAGE	<input type="text"/>
COMPLIES WITH THE APPLICABLE REQUIREMENTS OF ANSI/ITSDF B56.1 STANDARDS	
GLOBAL INDUSTRIAL Port Washington New York 11050	

Name Plate

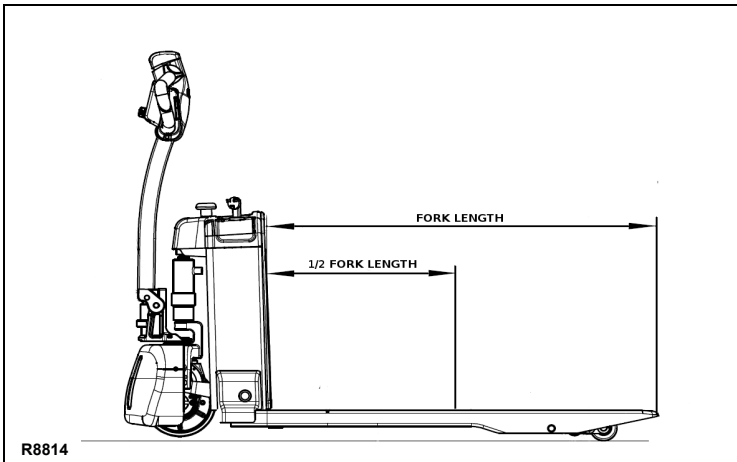

Load Center

## BEFORE OPERATION

The table on [page 10](#) covers important inspection points on trucks which should be checked prior to operation. Depending on use, some trucks may require additional checks.

The illustration on page 10 shows a sample format for an Operator Checklist, which can be modified as necessary to fit your operation.



**WARNING:**

Periodic maintenance of this truck by a QUALIFIED SERVICE TECHNICIAN is required.



**WARNING:**

A QUALIFIED SERVICE TECHNICIAN should check the truck

monthly for proper lubrication, proper fluid levels, brake maintenance, motor maintenance and other areas specified in the parts and service manual maintenance section.



**WARNING:**

If the truck is found to be unsafe and in need of repair, or contributes to an unsafe condition, report it immediately to the designated authority. Do not operate it until it has been restored to a safe operating condition. Do not make any unauthorized repairs or adjustments. All service must be performed by a qualified service technician.



## Sample of Operator Check List



### Electric Truck Daily Operator Check-Off List

Date \_\_\_\_\_ Operator \_\_\_\_\_

Truck No. \_\_\_\_\_ Model No. \_\_\_\_\_

Dept. \_\_\_\_\_ Shift \_\_\_\_\_

Hour Meter  
Reading—Drive \_\_\_\_\_ Hoist \_\_\_\_\_

Check	O.K. (✓)	Need Maintenance
Tires		
Load Wheels		
Horn		
Lift—Lower Control		
Attachment Operation		
Forward & Reverse Controls		
Steering		
Brakes		
Hydraulic Leaks, Cylinders, Valves, Hoses, Etc.		

## Operator Checks

ITEM	PROCEDURE
Transmission and hydraulic systems	Check for signs of fluid leakage and/or abnormal noise.
Forks and Frame	Check for cracks and damage.
Guards and load backrest	Check that safety guards are properly secured and not damaged.
Safety signs	Check that warning labels, nameplate, etc., are in good condition and legible.
Horn	Check that horn sounds when operated.
Steering	Check for binding or looseness in steering arm when steering.
Tiller switch/Parking brake	Check that steering arm raises to upright position when released and brake applies.
Brakes	Check that brakes actuate when steering arm is raised to upright position, and when lowered to horizontal position.
Travel controls	Check that speed controls on control handle operate in all speed ranges in forward and reverse and that belly button switch functions.
Wheels	Check drive wheel for flat spots, cracks or damage. Move truck to check load wheels for freedom of rotation.
Hydraulic controls	Check operation of lift and lower to their maximum positions. Check the oil levels.
Electrical	Check that there is no damage to the cables on the truck and that the horn and lift buttons work.
Battery disconnect	Check that battery can be disconnected and reconnected. Check for connector damage.

# INSTRUMENTS AND CONTROLS

The steering arm and control handle provide controls for steering, forward and reverse speed control, braking, raising and lowering the forks, and horn. Control handles on all models have a “belly-button” reversing switch which reverses the direction of the truck upon contact with the operator.

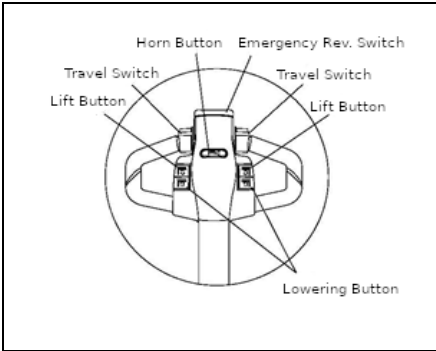

## Control Handle - Top

On the 989069 holding down one of the red “Turtle” buttons on the back of the handle and at the same time activating the accelerator you can move the truck in desired direction with the steer handle in the upright position. This helps you out to move the truck in tight spaces.



## Control Handle - Back

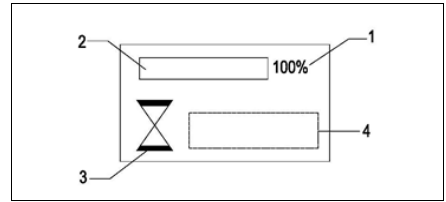

## Display Unit

### Display Unit

- The LED display (1) shows the residual battery capacity, when it's lower than 20% it must be charged.
- When the display (2) shows “NO BMS” the communication with the battery is disconnected and when it shows “BMS EER” the battery temperature or voltage is unbalanced.
- When display (3) is solid On the interlock switch is open. when flashing the interlock switch is closed and the running time will start.
- The display (4) will normally show the total running time however if there is a fault code on the truck it will be displayed here.

The display unit has a range between 0 to 99999 hours and it will log hours when traveling or lifting.

The battery discharge indicator has a memory function. It will display the state of charge (SOC) stored in memory, until a full charge cycle has been completed, and the battery SOC reset threshold is exceeded

### Low Voltage Protection

When the battery power is low the Low Voltage Protection will prevent the forks from being raised and you must charge battery.

# OPERATION

## Driving Instructions

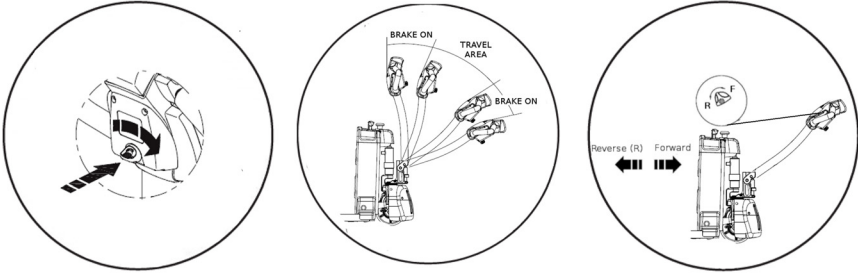

1. Turn the key to turn the truck on or off.

2. Tilt the steering arm to the travel position.

3. Turn the travel switch to move forward or reverse

R8815

## Forward and Reverse Travel and Speed Control

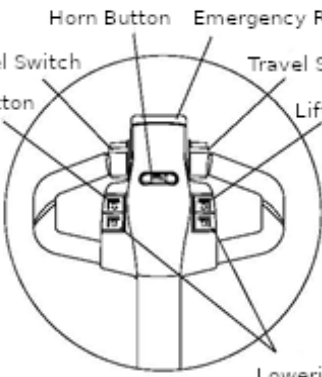

Horn Button    Emergency Rev. Switch

Travel Switch    Travel Switch

Lift Button    Lift Button

Lowering Button

R8624

## Control Handle

### Control Handle

All directional and speed controls are located on the control handle.

Forward and reverse are controlled by rotating the speed control lever as shown. The lever is spring loaded to return to neutral when released. Further rotation in either direction will

progress the truck from slow to maximum travel speed.

To change directions or to stop the truck, rotate the speed control lever in the opposite direction. The truck will come to a stop and then, unless the controls are returned to the center neutral position, accelerate in the opposite direction.

## Steering

Moving the control handle (which connects to the steering arm) right or left will turn the truck right or left. When maneuvering around corners, make square turns and be sure there is adequate clearance.

## Stopping

Stop the truck as gradually as possible. Unnecessary rapid stopping could be hazardous. Load could become unstable.

To stop the truck's movement (forward or reverse), raise the control handle to the up position or push the control handle all the way down. In both positions, the brake will apply. To release the brake, just move the control handle to the operating position.

**NOTE:** The steering arm gas spring automatically raises the steering arm to the upright position when the steering arm is released.

**CAUTION:** If the control handle does not raise immediately to the vertical position when released, the truck should be placed "OUT OF SERVICE" until it can be inspected by a qualified service technician.

## Parking

When parking the truck, do not obstruct traffic lanes or aisles.

1. Park the truck in its designated parking area.
2. Raise the steering arm until vertical to apply parking brake.
3. Fully lower forks.

4. Remove the key from the keyhole.
5. On the 989069 push the red disconnect plunger to remove all power from the truck circuits.

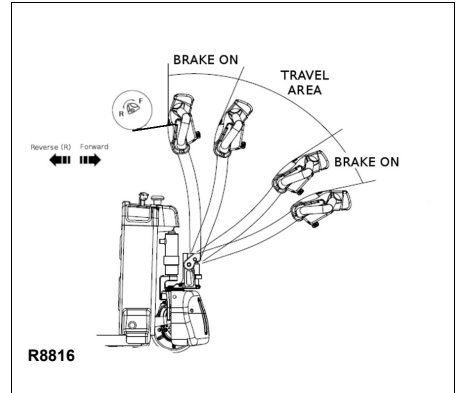

**Steering Arm Braking Positions**

## Load Handling

Handle only loads arranged for stability and always use caution. Raise and lower the load smoothly to prevent the load from falling.



### **WARNING:**

Always be sure the load and load center are within the capacity of the truck. If in doubt check the nameplate.

1. Approach the load slowly.
2. Move the truck slowly into position so that the forks are within pallet or skid, and the load is centered over the forks and as far back as possible.
3. Push the button to raise the forks and lift the load.

4. Lead the truck by the control handle with the load trailing except when in confined areas. Ramps should be traveled with operator uphill of truck when empty, or operator downhill of truck with load on forks standing off to side of truck.
5. Always look in the direction of travel. Move slowly and check clearances when approaching obstructions.
6. Do not make sudden starts and stops. Operate truck smoothly and gradually.
7. Travel slowly and squarely around corners. Remember that the trailing load wheels do not follow the turn path of the drive wheel. Instead they tend to cut the corner.
8. Line up the truck with the unloading area.
9. Stop the truck and check the load alignment with surrounding objects.
10. Be careful not to damage or move adjacent loads and objects.
11. Lower the forks by pushing the lowering button until the load is resting on its own.
12. Move the truck back until the forks are clear of the pallet.

### Moving a Disabled Truck

Do not attempt to move a disabled truck; notify your supervisor or proper authority.

### Battery Charging



**WARNING:** Before removing the battery make sure that the truck is completely powered down.



**WARNING:** Before installing the battery make sure that the truck key is not on.

### Using internal charger

Proceed as follows:

1. Park truck at charging station with forks lowered and turn the key switch off.
2. Check the condition of the AC cord. If there are any cuts in the cable, any exposed wires, loose plugs or connectors, DO NOT attempt to charge the batteries. Contact appropriate personnel for repairs to be made.
3. Pull the charger cord (1, see figure below) out of the top cover and connect to the appropriate power supply.

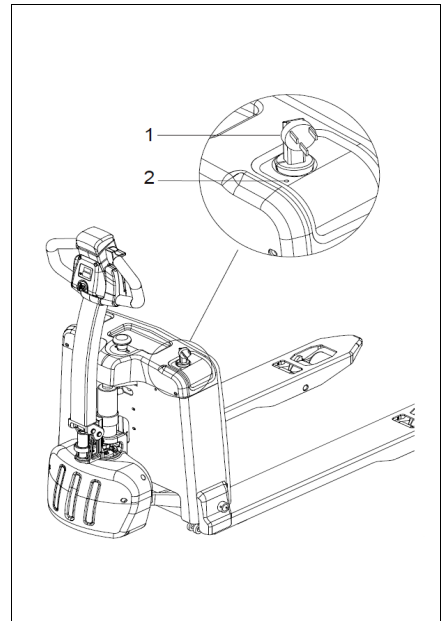

**Internal Battery Charging**

No.	LED Status	Symptom	Cause	Remedy	Description
1	Red Light		No Problem	/	Charging
2	Green Light		No Problem	/	Done Charging
3	No Light	Current / Voltage changes	Indicator failure	Return to factory maintenance	Charger failure
4	No Light	No change in current/voltage	The power input line is in good contact with the socket and the charger	Charger failure, return to factory maintenance	Charger failure
5	Red flashes		The power input cable is not in good contact with the socket	Check if the input power line is in good contact	
6	Yellow light on		Storage battery fails. (battery reverse connection)	Eliminate battery failure	
7	Yellow light on		Storage battery fails. (battery is not connected)	Eliminate battery failure	
8	Yellow flashes		Ambient temperature is too high	Ambient temperature drops to normal	
9	Yellow flashes		Battery voltage exceeds 32.5V	Eliminate battery failure	
10	Yellow flashes		Charger failure	return to factory maintenance	

### Charger LED Status Indicator

The following operating instructions appear on the truck warning decal, which is located near the steering arm.

Do not operate this truck unless you have been trained and authorized to do so, and have read and understand all warnings and instructions contained in this operator's manual and on this truck.

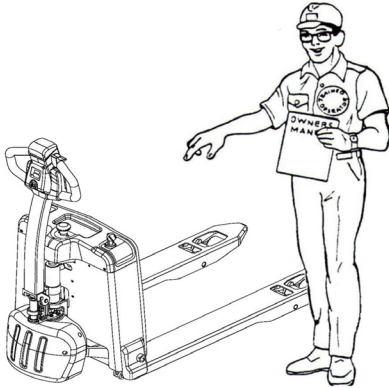

R8800

Do not operate this truck until you have checked its condition. Give special attention to wheels, horn, battery, controller, lift systems, brakes, steering mechanism, guards and safety devices. If you have any questions, notify your supervisor or proper authority.

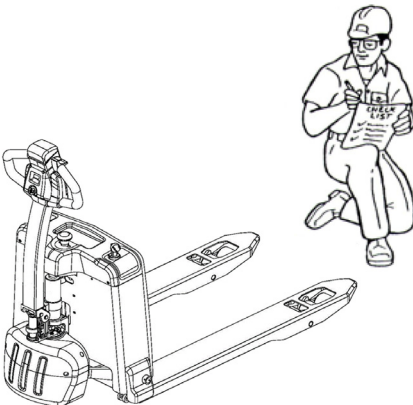

R8801



**Walkie Pallet Trucks:** Operate truck only from walking position.



R8802

Wear foot protection and keep feet clear of truck.



R88803

Do not carry passengers.

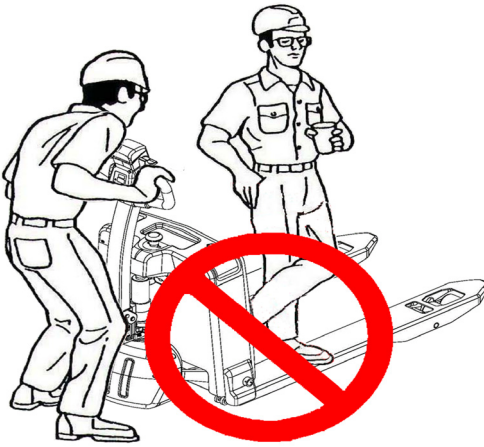

R8804

Observe applicable traffic regulations. Yield right-of-way to pedestrians. Slow down and sound horn at cross aisles and wherever vision is obstructed.

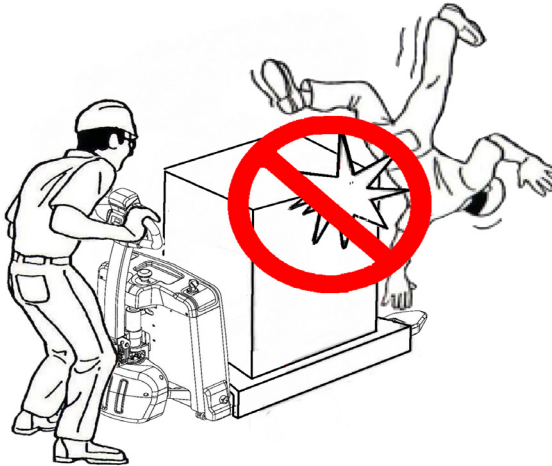

R8805

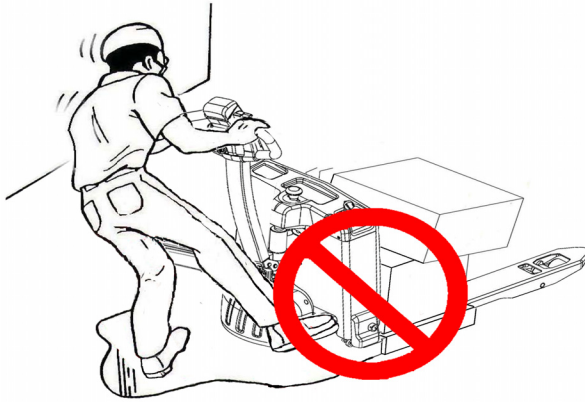

R8806

Start, stop, travel, steer and brake smoothly. Slow down for turns and on uneven or slippery surfaces that could cause truck to slide or overturn. Use special care when traveling without load as the risk of overturn may be greater.

Always look in direction of travel. Keep a clear view, and when load interferes with visibility, travel with load or lifting mechanism trailing (except when climbing ramps).

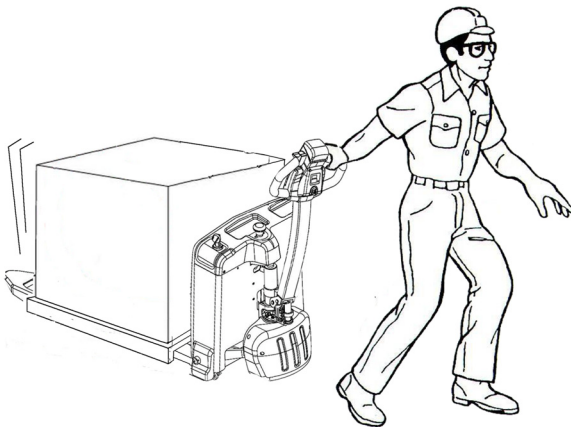

R8807

Use special care when operating on ramps; travel slowly, and do not angle or turn. Travel with lifting mechanism downhill.



R8809

Do not handle loads which are higher than load backrest or load backrest extension unless load is secured so that no part of it could fall backward.



R8810

Before lifting, be sure load is centered, forks are completely under load, and load is as far back as possible against load backrest.

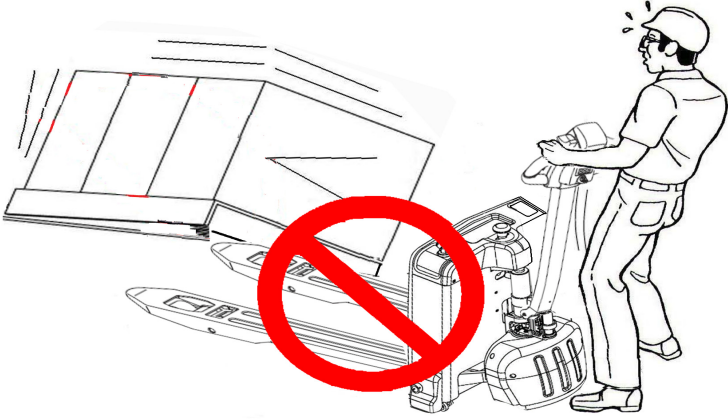

R8811

Keep hands out of lifting mechanism.

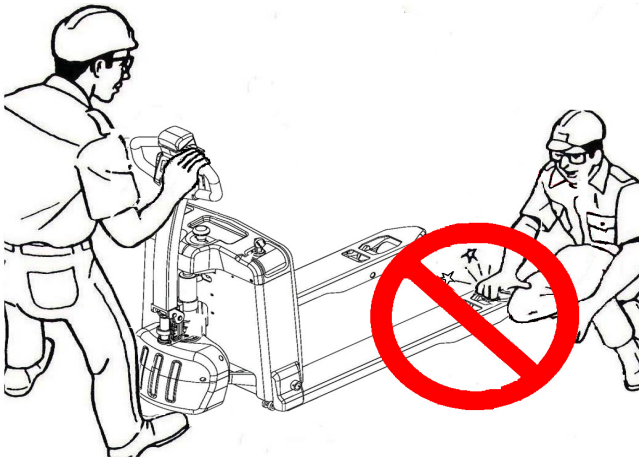

R8812

When leaving truck neutralize travel control. Fully lower lifting mechanism and set brake. When leaving truck unattended also shut off power.

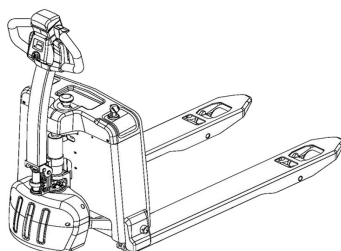

R8813

## **NOTICE - OBTAINING A PARTS AND SERVICE MANUAL**

A complete parts and service manual covering this truck is available from Global Industrial.

