

318504

Operation Manual

Contents subject to change without notice

Version 1.0

Issue AA

General Information

The 318504 Mechanical Physician Scale is ideal for use in health clinics and medical practices for height and weight measurement. The scale is durable, having a sturdy enameled steel body, removable slip-resistant plastic cover, a retractable aluminum height rod, and rear wheels.

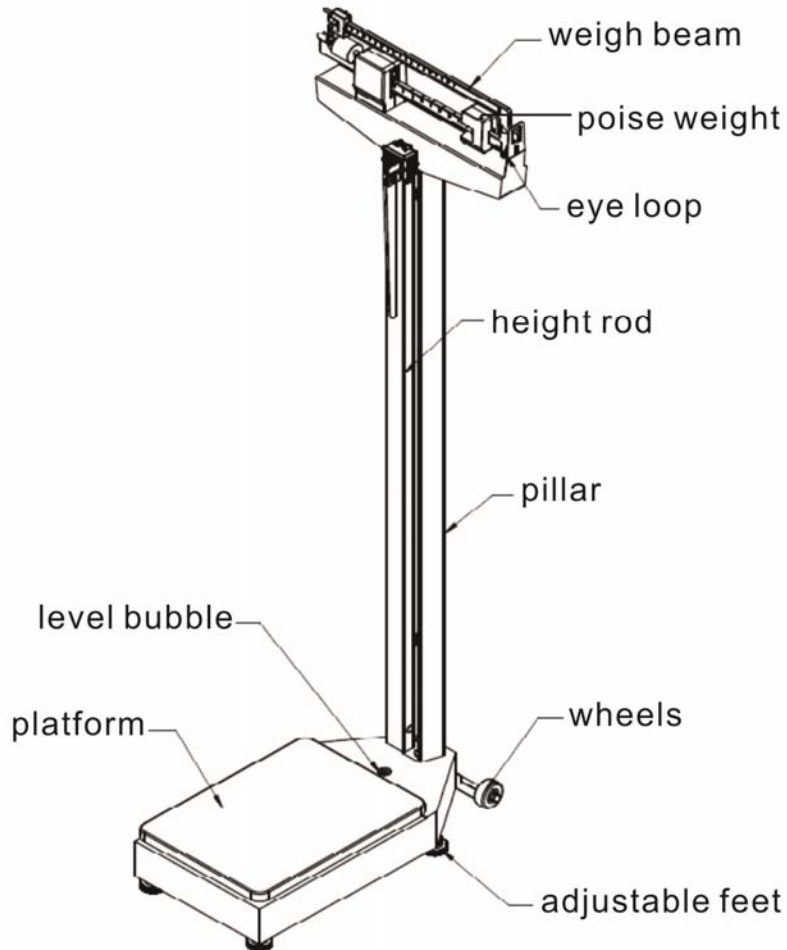

Specifications

Model	318504
Max Capacity	450lb
Weight Graduation	0.25lb
Height Measurement Range	24-84"
Height Graduation	0.125"
Platform Size	14.75" x 10.75"

Assembly

The 318504 Mechanical Physician Scale comes partially assembled. The following components require assembly:

- Pillar
- Steel connection rod
- Height rod
- Wheels

Tools required:

- Phillips head screwdriver
- Wrench (included)

1. Set the scale base on a table or other assembly area free from traffic and obstructions.
2. Remove the tie that secures the steel rod during transit (shown in Figure 1).



Figure 1. Remove Cable Tie

3. Insert the pillar into the scale base (shown in Figure 2), ensuring that the Global logo on the weight beam faces the scale base.

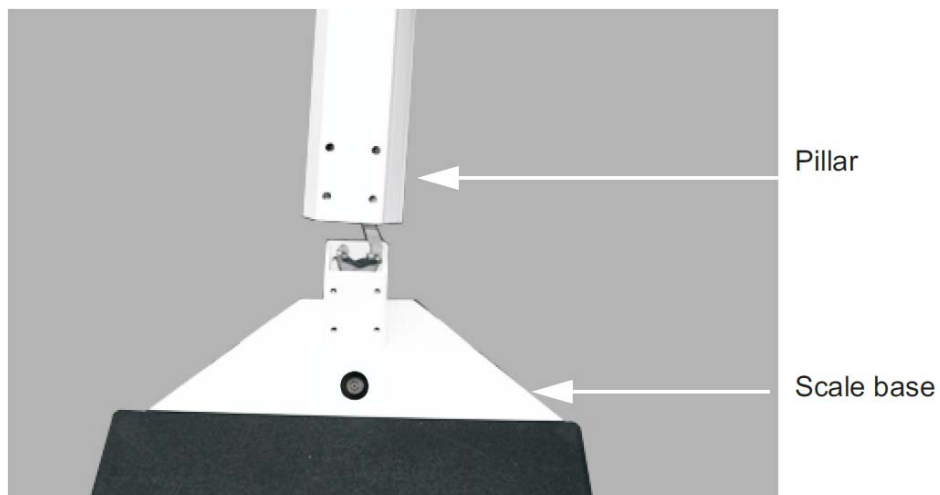

Figure 2. Attach the Pillar to the Scale Base

- Using a Phillips screwdriver, screw in the eight bolts and washers to secure the pillar to scale base as shown in Figure 3.



Figure 3. Attach Eight Bolts and Washers to Secure the Pillar to the Base

- Lay the scale on a table. Remove and discard the shipping tie wrap wires on the underside of the scale carriage as shown in Figure 4.

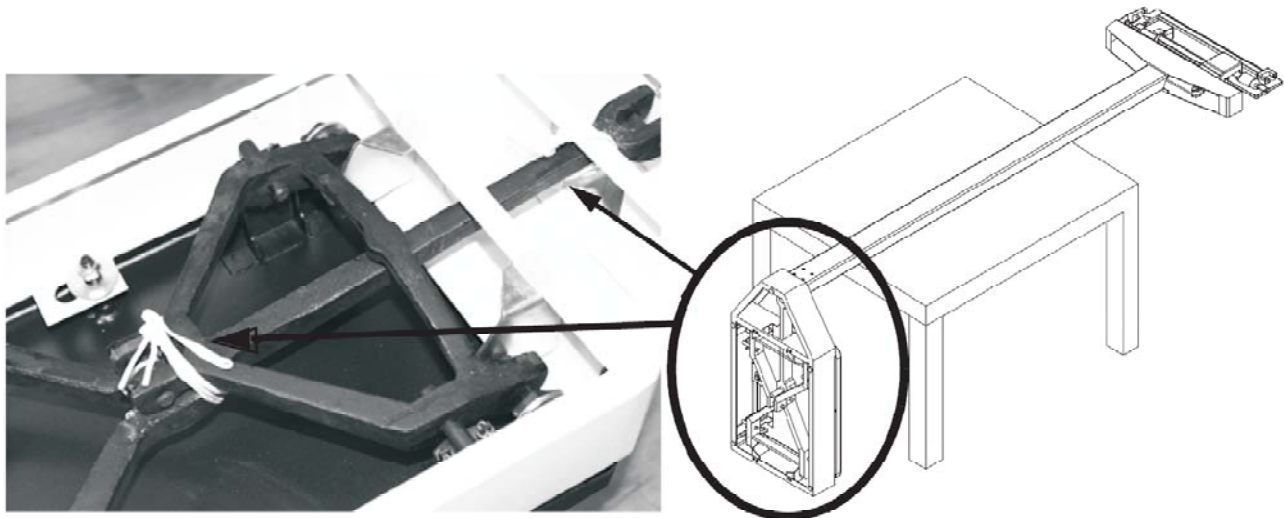

Figure 4. Lay Scale on Table to Access Bottom of Scale

- Insert the wrench (included) into the small hole in front of the steel rod and pull the rod hook with the wrench to connect it to the scale base as shown in Figure 5. The steel rod is located inside the scale pillar. Once the pillar is attached to the scale base, the steel rod must be attached to the bottom of the scale.

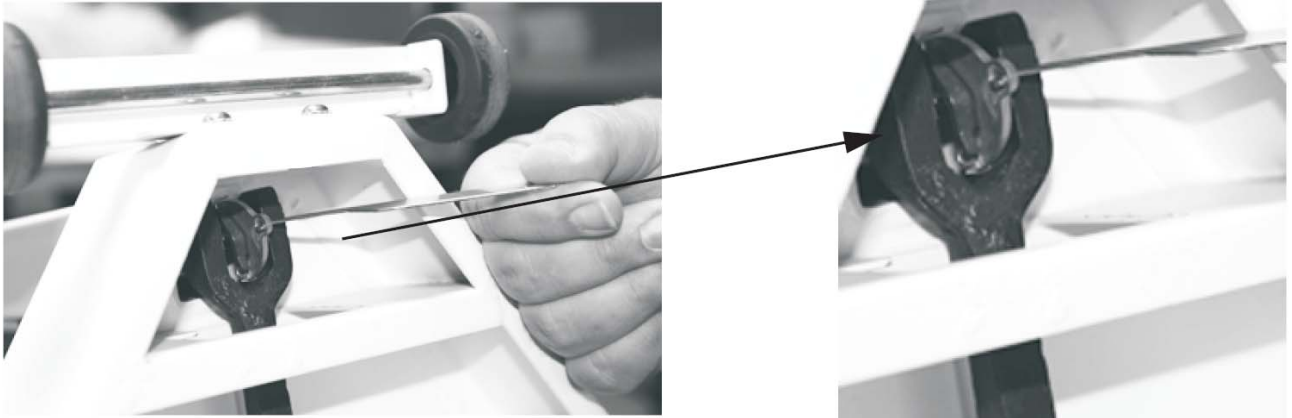

Figure 5. Connect the Steel Rod to the Scale Base

7. Push the long lever forward and hook the steel rod's bearing on the long lever pivot.

NOTE: During shipping, a plug is installed to ensure that the force lever assembly stays aligned, but the linkage may still come out of alignment. Visually ensure that the force lever assembly linkage is centered and properly aligned. The linkage must be free floating in order for the scale to weigh properly. If the scale is slightly tipped to one side, the linkage can be seen by looking up underneath the top weigh beam.

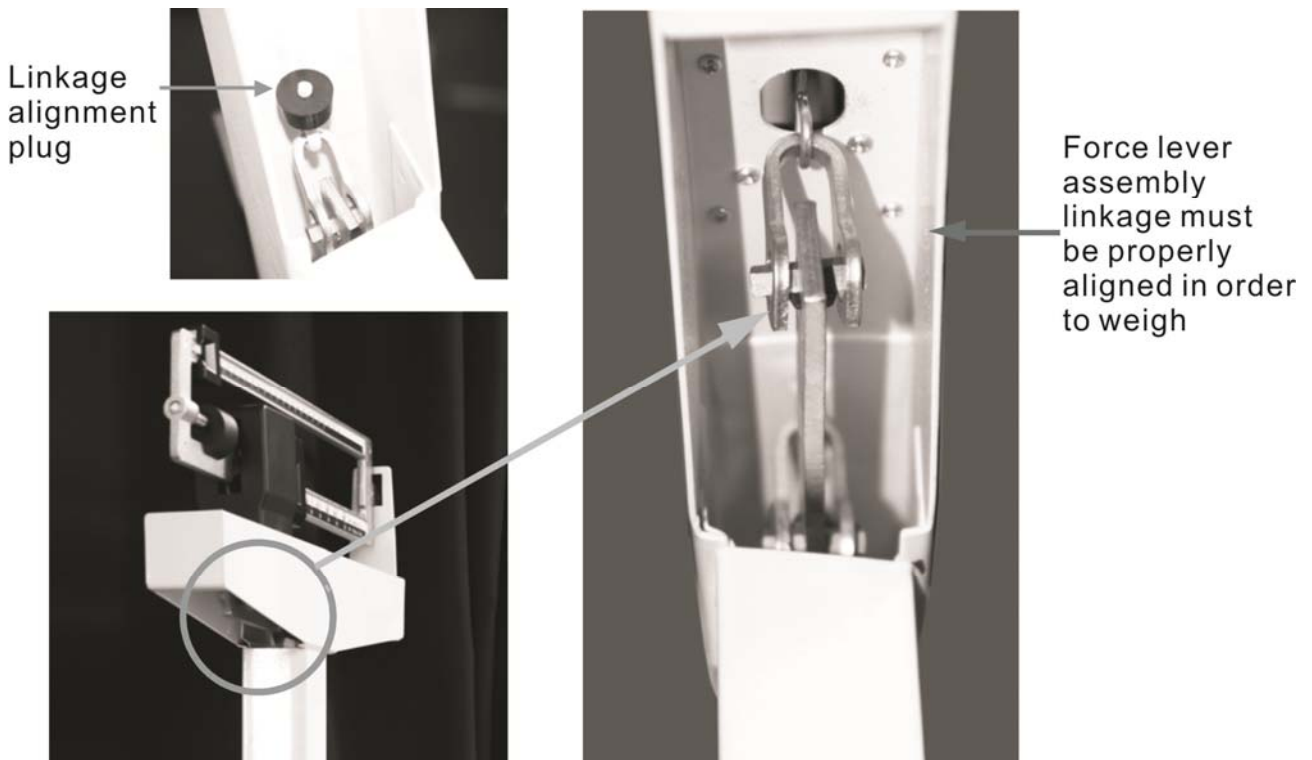

Figure 6. View of Linkage Underneath the Top Weigh Beam

8. Place the scale gently back on the floor.

Height Rod Assembly

1. Insert the slotted holes on the back of the height rod into the two bolts on the front of the pillar as shown in Figure 7.
2. Use the enclosed wrench to tighten the two hex-head screws. Be sure not to over-tighten.
3. To raise or lower the height rod, press the red button at the top of the height rod.

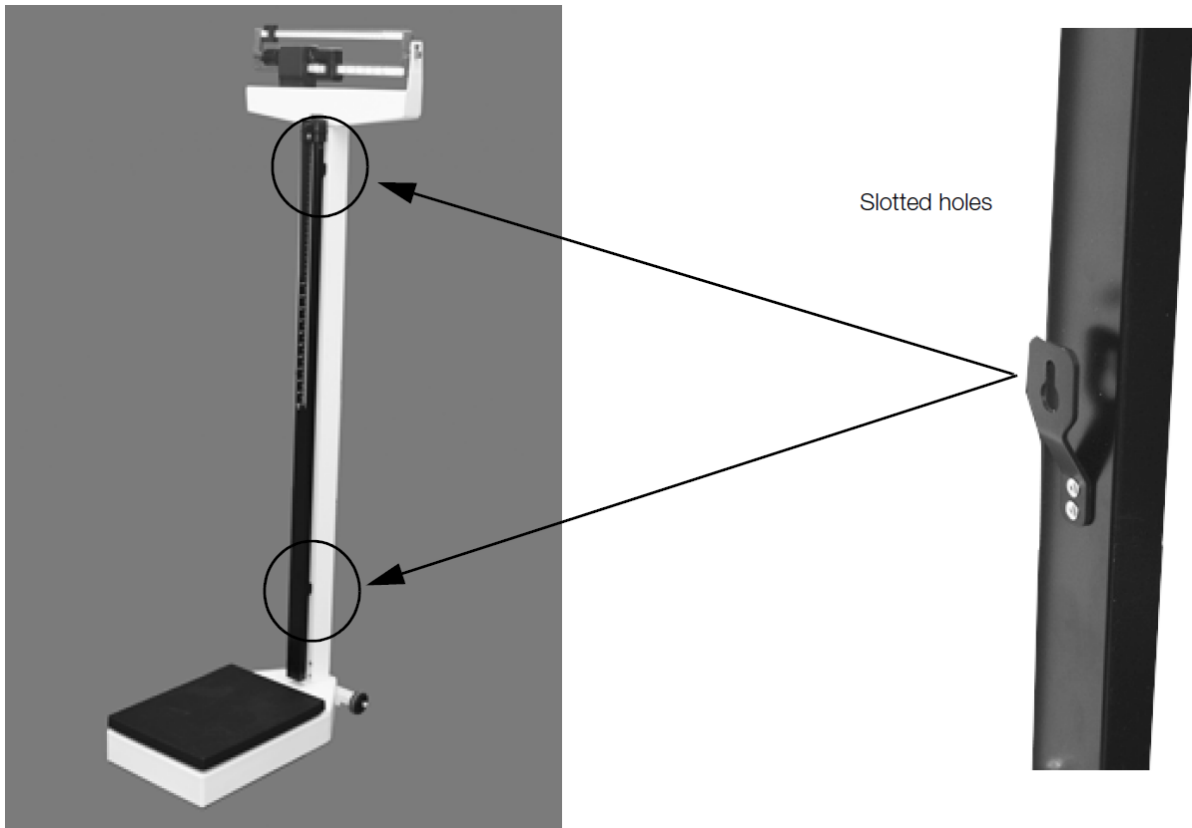

Figure 7. Attach the Slotted Screw Location onto the Pillar Bolt Location

Wheel Assembly



Note Mounting the wheels upside down can cause weighing errors.

1. Align the angle iron of the wheel base to the scale platform as shown in Figure 8.
2. Use the screws and washers that are included to affix the wheel assembly to the platform. Adjust the angle iron at a level position and then tighten screws.
3. When moving the scale, hold the two side faces of the pillar to keep the front side of the platform away from the ground.



Figure 8. Attach the Scale Wheels onto the Scale Base

Zero Adjustment

After assembly, the scale must be zeroed prior to use.

1. Ensure the scale is sitting on a level surface and slide the upper and lower weights to the far left positions.
2. Gently hold the scale pointer with your finger so it is centered within the eye loop area. Release the scale pointer and let it rise freely up or down.
3. If the pointer doesn't remain centered, turn the zero adjustment screw (shown in Figure 9) using a flathead screwdriver until the pointer remains centered within the eye loop.



Figure 9. Eye Loop Area and Zero Adjusting Screw Location (shown without height rod)

Troubleshooting

The Mechanical Physician Scale is factory-calibrated to within plus or minus 1/4 pound accuracy. For the most accurate readings, always use the scale on a hard, level surface and stand in the center of the scale platform with the weight evenly distributed. If an error occurs or seems excessive, check the following:

Problem	Possible Solution
Zero balance out of adjustment	<ul style="list-style-type: none"> ▪ The weighing beam must be balanced so the pointer comes to a rest in the center of the eye loop (shown in Figure 9) when both poise weights are set at zero (see page 1 for poise weight location). Follow zero adjustment instructions on page 7.
Beam does not move freely	<ul style="list-style-type: none"> ▪ Make sure the pointer is not touching the side of the eye loop, impeding its range of travel. ▪ Visually ensure that the linkage is centered and properly aligned. Occasionally during shipping, the alignment will become skewed. The linkage must be free floating in order for the scale to weigh properly. If the scale is slightly tipped to one side, the linkage can be seen by looking up underneath the top weigh beam.
Platform rocks excessively	<ul style="list-style-type: none"> ▪ Ensure scale is setting on a level surface. When you push down on any corner of the platform, you should not feel any significant rocking.
Beam does not move at all during weighing	<ul style="list-style-type: none"> ▪ Weights are set higher than the person's actual weight. Reset the weights to a lower weight. ▪ Make sure steel rod is properly connected and aligned as in Figure 5.
Scale is out of calibration	<ul style="list-style-type: none"> ▪ Recalibrate the scale by placing a known weight on the scale and turning the zero adjustment screw until the pointer remains centered within the eye.



11 Harbor Park Drive Port Washington, NY 11050