

THE INSTALLATION AND REPLACEMENT OF BATTERIES

- When the indicator appears low battery prompt, please replace the batteries in time.
- In order to avoid liquid soap outflow, make sure the product is straight up when installing battery.
- Please use standard batteries (DC 6V/AA battery (4pcs)). New and used batteries can't be mixed. The usage as follows:
 - Unscrew the battery box with the screwdriver.
 - Press handles on both sides and take down the battery box.
 - Put the new batteries into battery box in the direction of "+" and "-" .
 - Put the battery box back and click it to the proper position, tighten the screws.

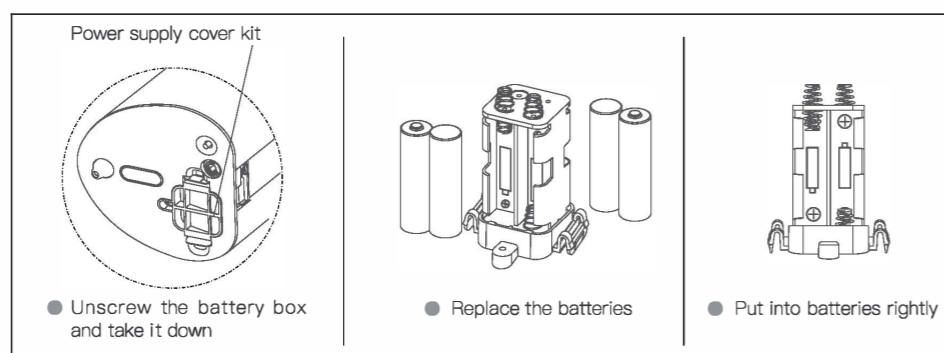

HOW TO USE

- Unscrew the battery box by phillips screwdriver and take it down. Fill it with the batteries (DC 6V/AA battery (4pcs)) and put it back. Then tighten it by anti-theft screw for locking.
- Use the key to open top cover and add in the soap liquid. Please clean the surface if there is any soap liquid overflowing.
- Reach out your hands under the sensor. The indicator lights up and the soap liquid will drop down automatically as soon as the sensor receives the signal.
- For initial use, repeat step 3 until the liquid or soap drops normally.
- Low battery prompt: The indicator light flashes 3 times every 30 seconds. The battery is low. It is recommended to replace the batteries (4 batteries are replaced at the same time).

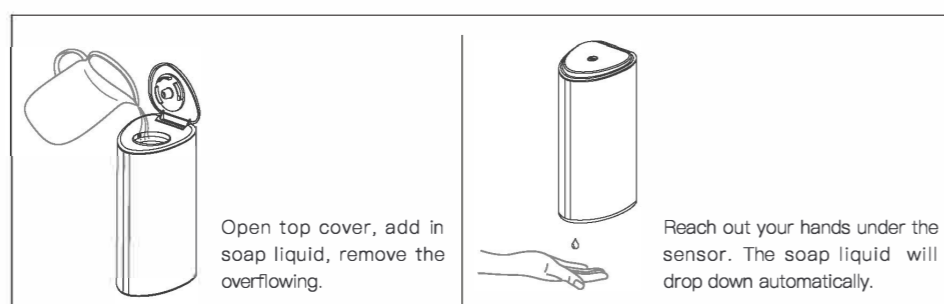

CAUTION & IMPORTANT SAFETY INSTRUCTIONS

READ AND KEEP THESE INSTRUCTIONS SAFETY PRECAUTIONS

WARNING—TO REDUCE THE RISK OF INJURE TO PERSONS OBSERVE THE FOLLOWING:

- To prevent children from eating the liquid soap, they must use this product in the presence of a guardian.
- To protect the environment, please dispose the exhausted batteries in an environment-friendly way. Please recycle the waste batteries as specified.
- Do not wash or shower the product as micro precision electronic components are contained.

CHECKLIST AND NOTES ON OPEN-PACKAGE

- Please check all the items (refer to the packing list) before installation. If any parts are missing or have problems, please contact your regional dealer or contractor in time.
- Any change of specification is subject to no notice. If there are any difficulties during installation, please contact your regional dealer or contractor in time.
- The main parts are packed in special bags. Please avoid violent hit or friction when handling and opening the box.

ATTENTIONS BEFORE INSTALLATION

TO MAKE SURE THE APPLIANCE DO WORK AND EXTEND ITS LIFESPAN UNDER THE GOOD CONDITION, PLEASE NOTICE THAT:

- The instructions manual must be followed carefully when installing.
- Use the same known brand AA battery (4pcs) with good quality. New and used batteries can't be mixed. If the inferior batteries are counterfeit and shoddy, it may do harm to unit working and its lifetime.
- Before installation, please make sure the wall is plain and clean.
- Make sure the distance must be more than 25cm from the table or any reflective objects to the sensor.
- The instructions manual should be turned over to the user or person in charge after finishing the installation.
- Any objects should not be put within the sensing distance.
- No reflective objects such as stainless steel and photoelectric sensors are allowed to be installed on the table directly facing the sensing window, that will cause the appliance to work automatically.
- Indoor use only.

CAUTION:

- The unit is suggested to install batteries even if you don't use it, so that the unit will run automatically every 72 hours to avoid the catheter pressure adhesion.
- Some of unit had installed batteries and in dormant status before delivery. Keep press setting buttons for more than 5 seconds, the indicator will flash 3 times turning into standby status. Whereas if the unit turn to dormant status after keeping press the setting button, you can also re-installation batteries to turn the unit to standby status directly.

PACKING LIST

Automatic soap dispenser X1	Wall-mounted kit X1	ST4X25 screws X3	Key X1
Expansion screws X3	User Manual X1	Certificate of Qualification X1	

SPECIFICATIONS

Voltage	DC6V/ AA Battery (4pcs)	Supply	0.5-2.5ml(5 levels adjustable)
Volume	850ml	Sensing distance	5-9cm
Ambient temperature	0-45°C	Material	ABS

SUPPLY VOLUME SETTINGS

- After the machine is powered on, please press the setting button for more than 3 seconds and the indicator light flashes for 3 times. The machine will enter the standby state and the liquid output will be automatically adjusted to the factory default setting.

Adjustments

At the standby status, press the setting button (hands off when indicator lights up) to adjust the supply volume including 5 different levels. The default of the unit is about 1.0ml (refer to the water volume), then press once to be 1.5ml, twice 2.0ml, three times 2.5ml, four times 0.5ml, five times will be back to the default to finish a circle.

SIMPLE TROUBLESHOOTING ACTIVITIES

Status	Causes	Methods
Indicator not work	Controller fault	Replace the controller
	Abnormal power supply	Check circuit or battery
	Loose contact or power running out	Reload or replace batteries
	Disconnection or loose contact of internal wiring	Check internal wiring
Indicator flashes frequently	Dirty sensor window	Clean sensor window
	Insufficient power supply	Recharge or change batteries (DC 6V/AA battery (4pcs))
No liquid soap supply	On-going sensing	Remove reflective object
	Long sensing distance	Put hands down enough to get the sensor induction or slowly move hands up & down
Insufficient liquid soap supply	Malfunctioning machine	Contact regional dealer or contractor
	Supply liquid soap within short time	Make an adjustment referring to the user manual
	Extremely dense liquid	Refill low density liquid
	Liquid solidified or pipe blocked	Repeatedly to use it until the liquid supply is normal Contact regional dealer or contractor

Warning: No impurities and other dirt in the tank to avoid blocking.

WARRANTY

- One year for free warranty from the date of invoice.
- The range of warranty is exclusive of normal depreciation or any damages caused by improperly using.
- It's not in the range of warranty if the unit was repaired by user unauthorizedly, or was damaged by using the accessories not from the original manufacturer.
- For the product failure that out of warranty period, the manufacturer guarantees to repair. The charge will only cover the cost of material and delivery in principle.
- The other situations for repair but charge a certain cost:
 - Product damage caused by risks of fire, earthquake, flood, lightning and other forces of nature.
 - Product failure caused by improper installation and debugging or incompatible power supply.
 - Product failure caused by improper using & maintenance, intentional damage or severed in bad operating environment.
 - Damages caused by improper handling, re-fitting or repairing.
 - Fault caused by gelatinous, sediment or other impurities contained in the soap liquid.
 - Empty warranty card or even no warranty card. Or with altered user information.
- Safekeeping the warranty card and other vouchers to ensure the right of free after sales service. Please present the purchase receipt and fill in the user information stamped by dealer or contractor when you need the unit to be repaired.

Automatic Soap Dispenser

USER MANUAL



Model no. 641522

SKETCH MAP AS FOLLOWS

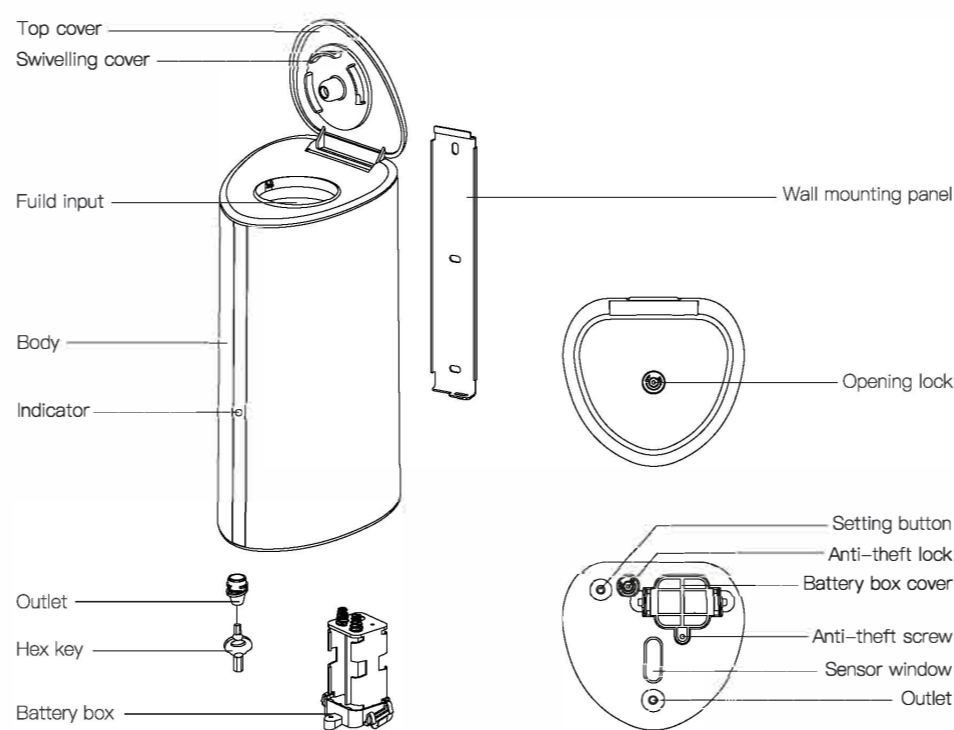

Notes: The sketch map refers to the unit, and please take the actual item as final reference.

SKETCH MAP OF INSTALLATION

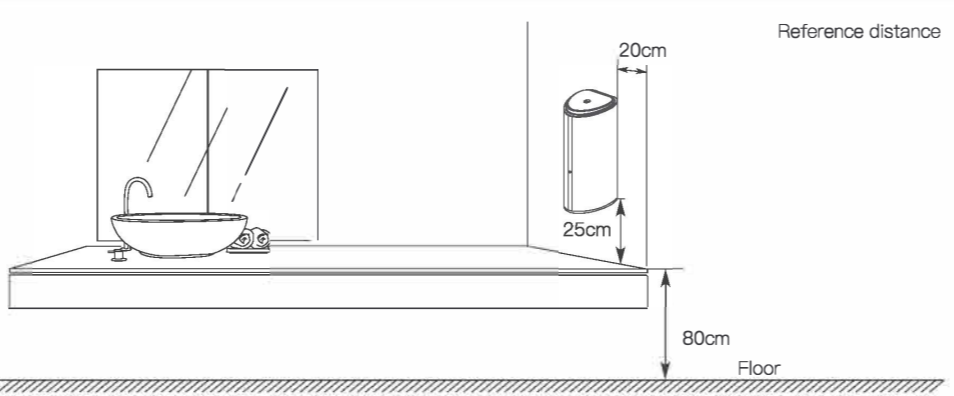

Caution: If the surface of table is made of stainless steel, the sensing distance must be over 35cm.

INSTALLATION STEPS

- Find a proper position on the wall, put the wall mounting panel on it and use pencil to mark the position of the three holes.

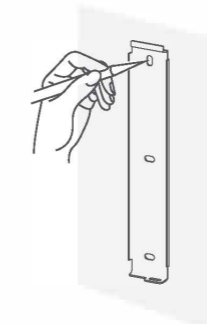

- Drill three holes (φ6) in the wall according to the marks. Put expansion screws into the holes.

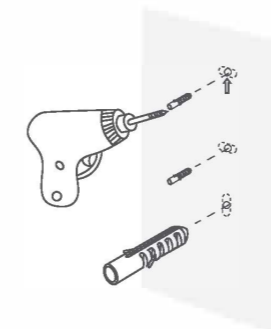

- Screws shall match with expansion screws in the wall, fix them together with wall mounting panel.

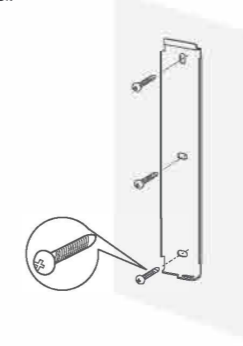

- Choose an appropriate angle. Put the upper slot (at the back of the unit) down into the upper hook (at the mounting panel). Make the dispenser fit tightly to the mounting panel. Push the dispenser slightly down to make sure both hooks be put in the slot well. Then use hex key to lock the anti-theft screw.

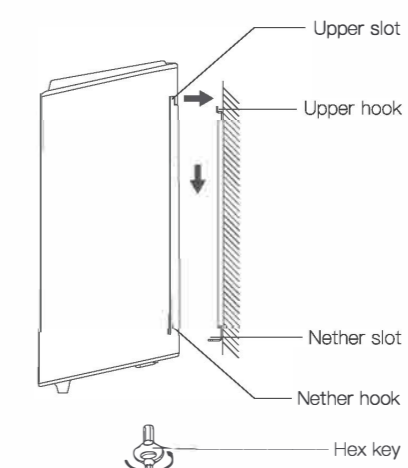

CAUTION

- Do not knock hard on the products to prevent the precision electronic components and solenoid valves from trouble.
- Be careful not to damage the connecting wire when dismantling.
- Please use neutral detergent to clean the surface. Firstly, dip the soft cloth into neutral detergent to wipe the unit, then wipe off the detergent and dirt by wrung-out wet soft cloth, finally to dry the unit by dry soft cloth. Do not clean this unit by showering or using non-standard cleaning solutions in case of surface damage or components corrosion. To keep this unit working in best condition please don't do anything that will damage the sensor window.