

# Semi-Auto Low Profile Stretch Wrap Machine

## User Manual

Model no. 412409

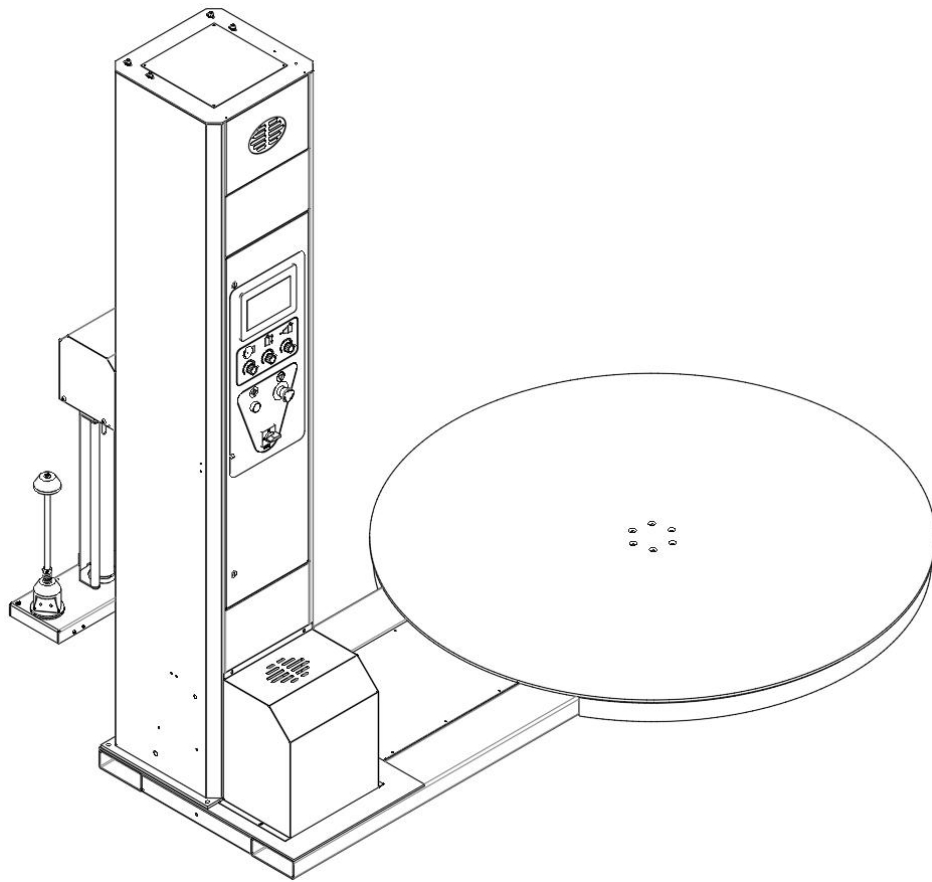

**Globalindustrial.com**

Customer Service  
US: 1-800-645-2986  
CA: 1-888-645-2986

---

**OPTIONAL**

Stretch Wrap Machine Ramp  
Model no. 412410



# Machine Dimensions

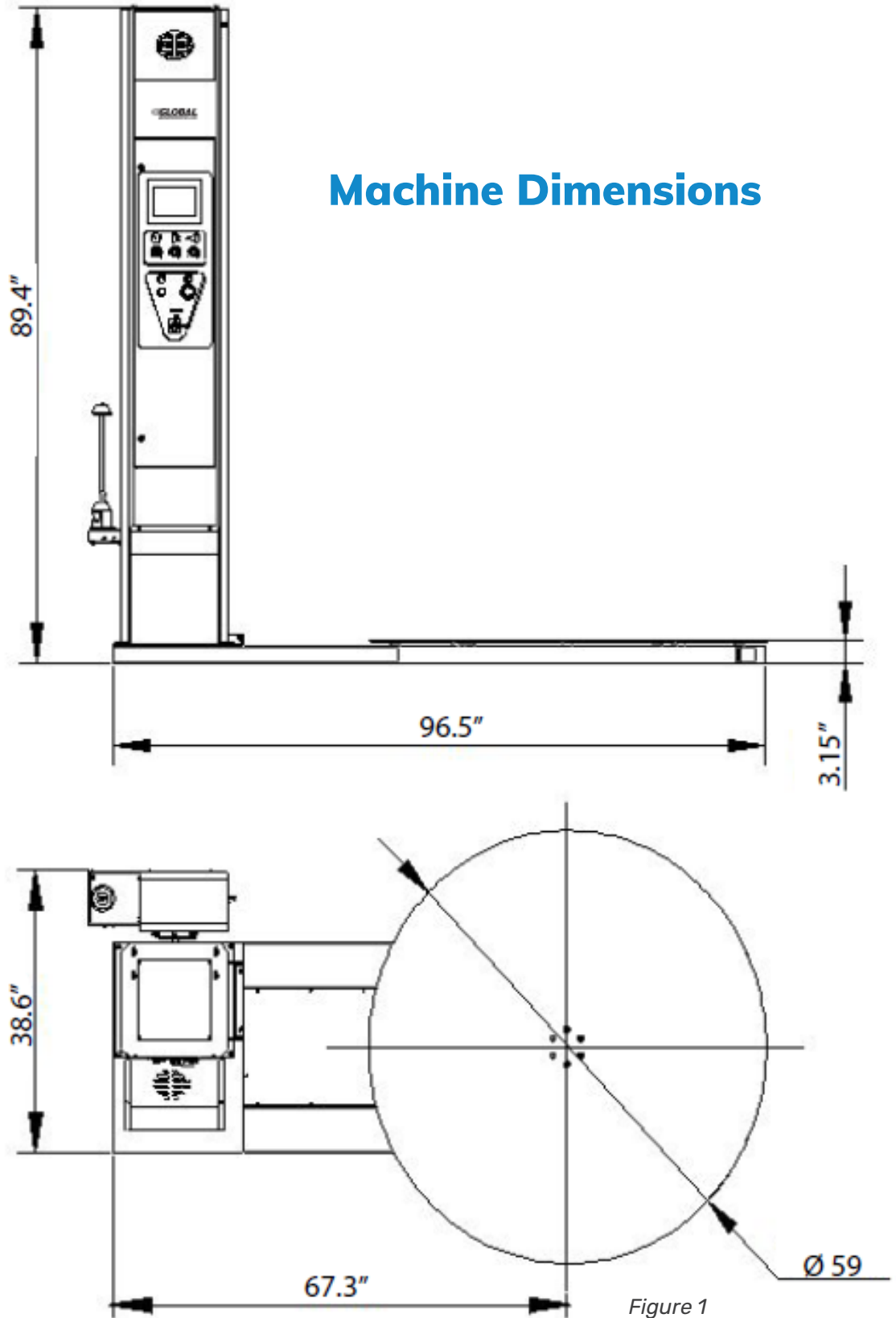

## Table of Contents

<b>1</b>	<b>System Specifications</b> .....	<b>4</b>
<b>2</b>	<b>System Set-up</b> .....	<b>6</b>
	2.1 Machine Set-up .....	<b>7</b>
	2.2 Installation .....	<b>8</b>
<b>3</b>	<b>Control Panel Buttons</b> .....	<b>10</b>
<b>4</b>	<b>Operator Controls</b> .....	<b>12</b>
	4.1 Manual .....	<b>12</b>
	4.2 Auto .....	<b>13</b>
	4.3 Input & Output (I/O) .....	<b>14</b>
	4.4 Film Loading .....	<b>14</b>
	4.5 Machine Operation .....	<b>16</b>
<b>5</b>	<b>Maintenance &amp; Troubleshooting</b> .....	<b>18</b>
<b>6</b>	<b>Components &amp; Parts</b> .....	<b>20</b>

# 1. System Specifications

## Machine Dimensions

(See Figure 1)

Table 1

Length	96.5"
Width	59"
Height	89.4"
Turntable Diameter	59"
Turntable Height from Floor	3.15"
Wrapping Height	83"
Operation Space	97" x 60" x 90"
Maximum Load Size	52" x 52" x 82"

## Electrical Specifications

- 110 VAC, 60 Hz, Single-phase, 9.1AMP
- Turntable motor: 550W
- Lift motor: 200W
- Pre-stretch Motor: 200W

## Turntable System

- 13 RPM turntable maximum speed
- 4,400 lbs. turntable maximum load capacity
- 1-10 round/minute
- Clockwise rotating turntable direction

## Film Delivery System

- Infinite / Manual Stretch Adjustment
- 10" Diameter Roll Capacity
- 3" inner film roll diameter
- 20" Roll Width Capacity

## Machine Features

- Programmable logic controller (PLC) user interface
- 6 modes: that's 5 automatic modes + 1 manual mode.
- The film carriage adopts close loop self-adjusting technology, to ensure each package is evenly wrapped.
- Allowable package weight (22 lbs – 4400 lbs)
- SAFETY: The machine has an emergency stop button & sensor underneath the film carriage. Once an object is detected underneath the moving film carriage, the machine will stop.

### CAUTION!

When servicing drive and controllers, there may be exposed components with housings or protrusions at or above the line potential. Extreme care should be taken to protect against shock.

The user is responsible for conforming to all applicable code requirements with respect to grounding requirements. Do NOT use extension cords to operate the equipment

Disconnect AC input power when the machine is not in use and before checking components, performing maintenance, cleaning up, and. Do NOT connect or disconnect wires and connectors while power is applied to the circuit.

Always plug into a grounded outlet with the rated voltage.



### STOP WARNING!

Loose clothing must NOT be worn while the machine is in operation. Stay clear of moving parts while the machine is running.

## 2. System Set-up

### Machine Placement

Place the Semi-automatic Stretch Wrap Machine close to an area where you will be wrapping your pallet loads. Refer to figure 2 to insure the machine meets the minimum clearance space requirements. Make sure that there is sufficient room to load/unload the machine and that you do not stretch the wiring cable. Remember, you will need to provide electrical service to a 110 VAC, 9.1-AMP outlet. (See Figure 2)

### Floor Weight Bearing Tolerance

The floor must be able to bear the weight of the machine, the weight of the maximum load, plus a safety factor. The floor must also be able to tolerate the stress of the machine operation. If the truck will operate on the same weight bearing area, add the weight of the trucks to the weight bearing stress tolerance requirement.

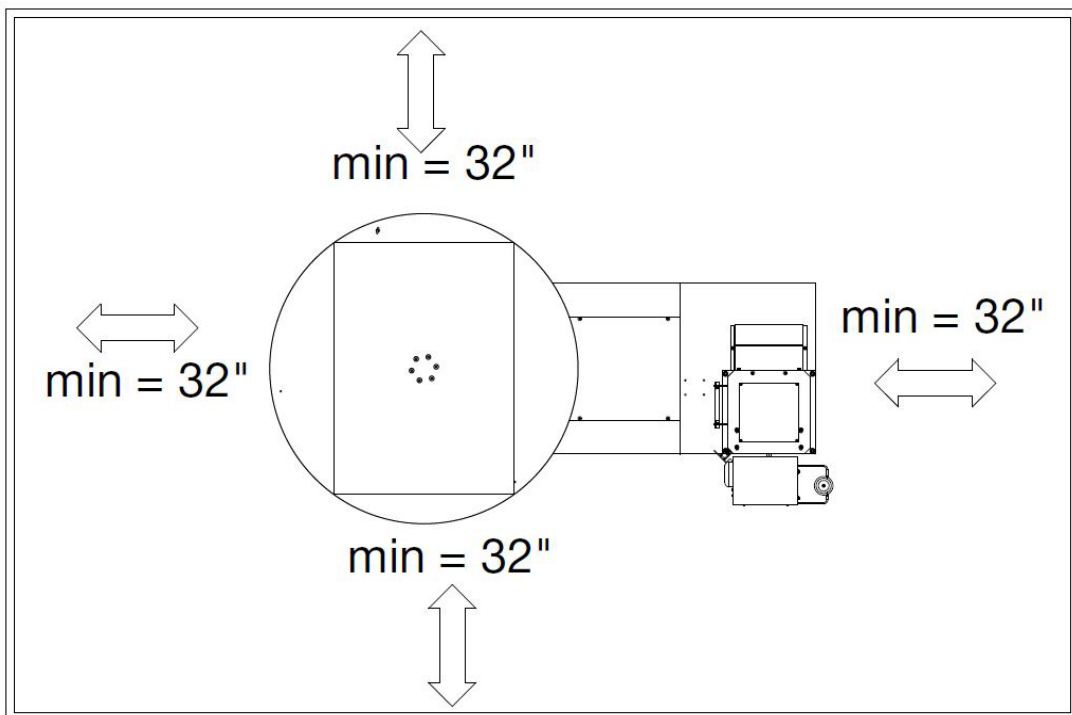

Figure 2

## 2.1 Machine Set-up

1. Place the crated machine close to the designated wrap area. Remove all shipping fasteners holding the machine to the pallet. The machine may be crated with the tower tilted down and the motor cover front carriage roller removed for shipping purpose.
2. Place forks of the forklift through the tubes provided at the rear base of the module, remove the machine from the crate and place it at the designated wrap area.
3. Check all internal connections to ensure there is no loose/disconnected electrical wiring.
4. Connect the motor wiring and sensor leads according to the corresponding wire numbers.
5. If the OPTIONAL ramp (Model no. 412410) is purchased: select a ramp position illustrated below. The ramp can be positioned anywhere in a 180° rotation around the front of the turntable. There should be a ¼" gap between the turntable and the ramp. The ramp should be fully supported by the floor. (See Figure 3)

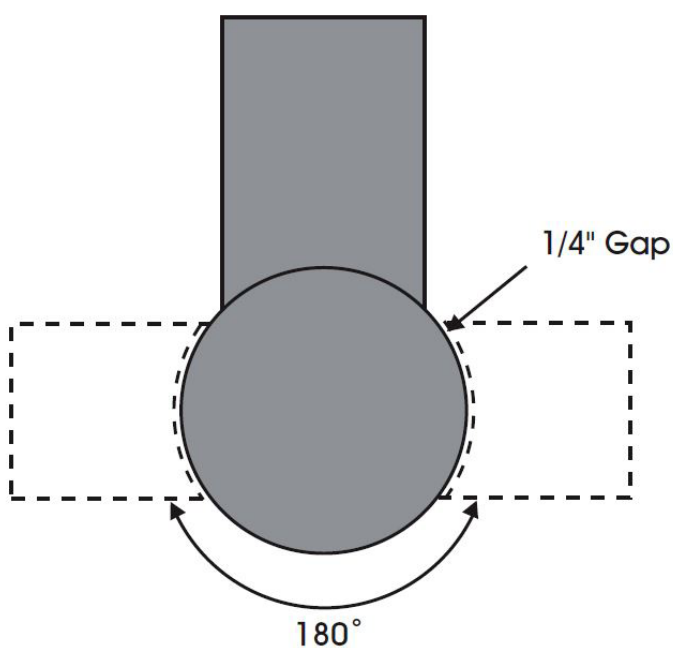

Figure 3

## 2.2 Installation

NOTE: Installation requires two people. 

### CAUTION

Be careful when standing on the turntable during the installation, as it may turn when rotational force is applied.

1. Raise the tower upright safely with two people.
2. Tighten the screw between the tower and the turntable base. (See Figure 4)
3. Screw the film carriage into the post. (See Figure 5)
4. Connect to the power supply and perform a ground test before using the machine.

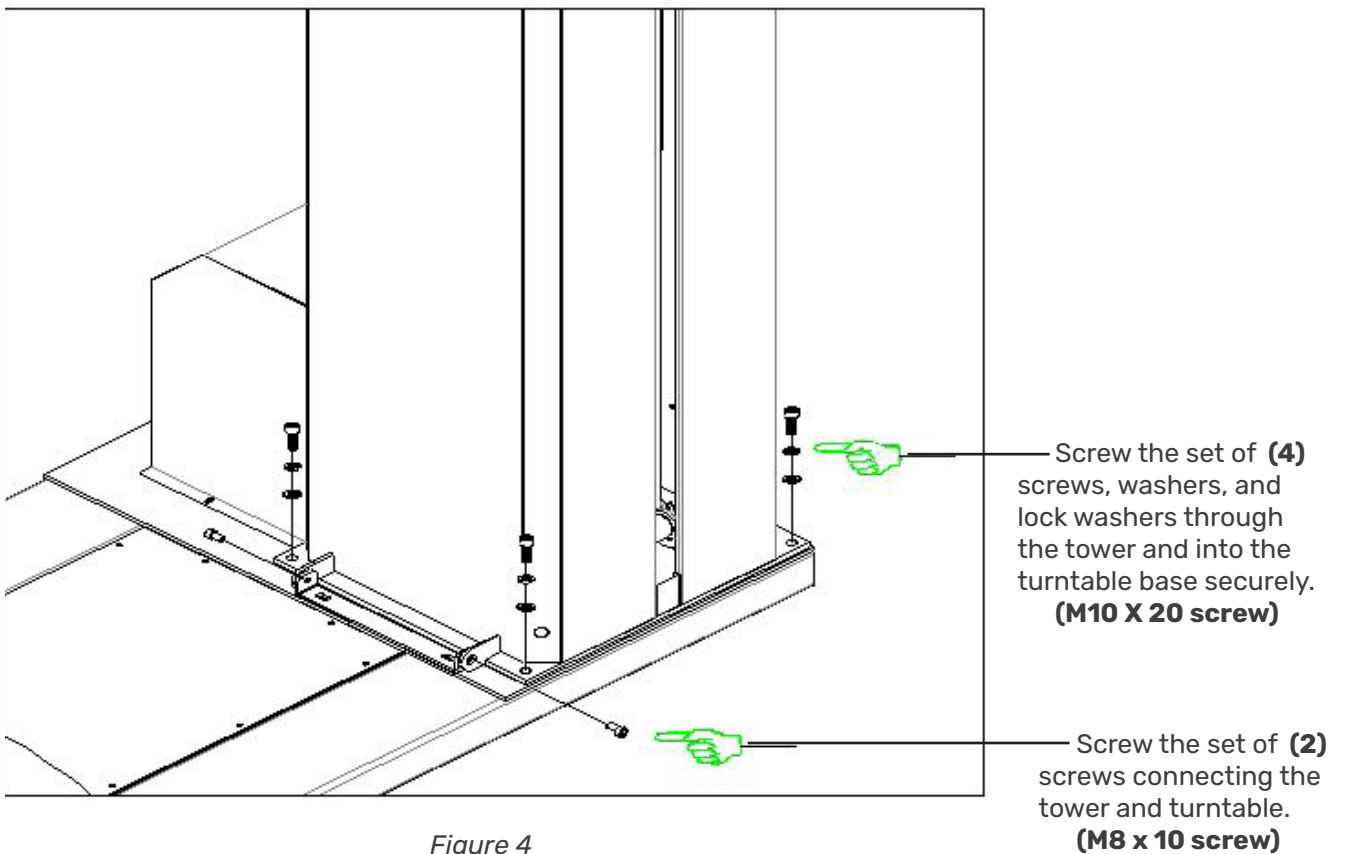

Figure 4



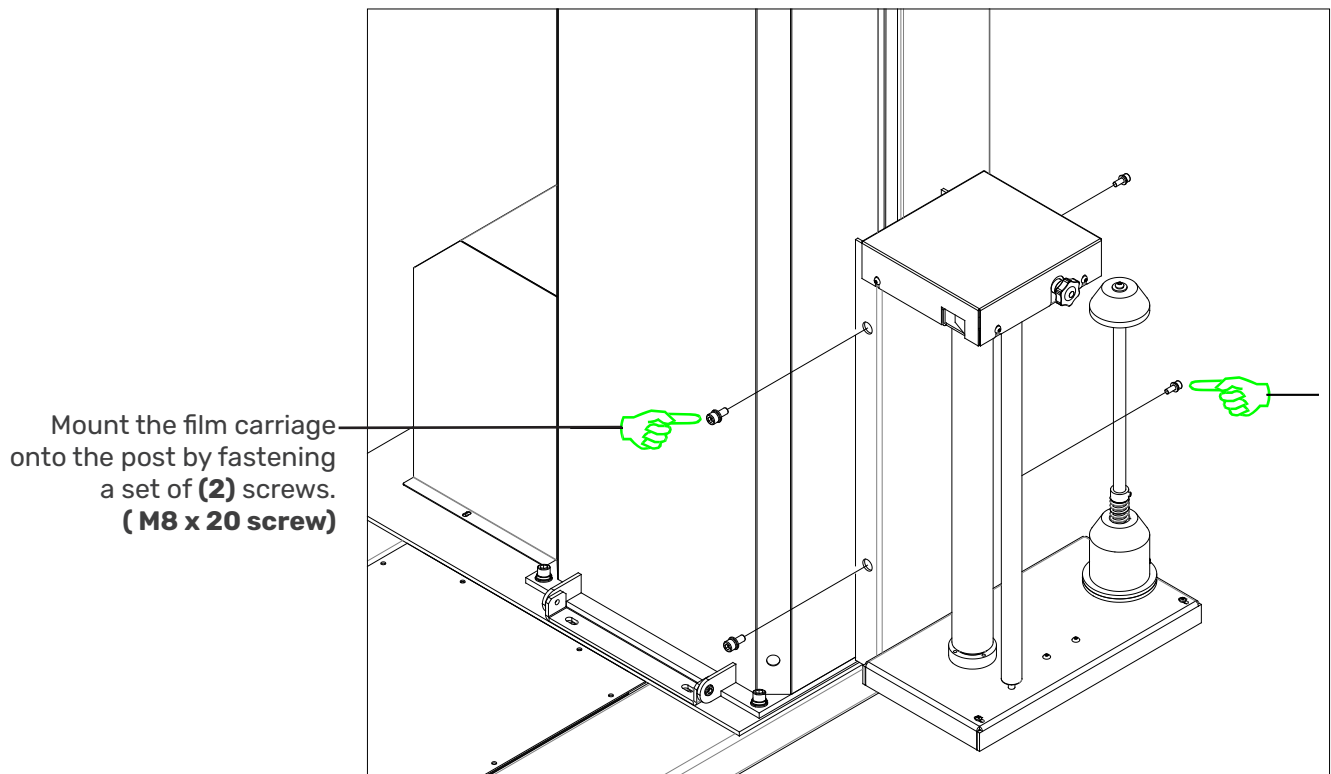

Figure 5

### 3. Control Panel Buttons

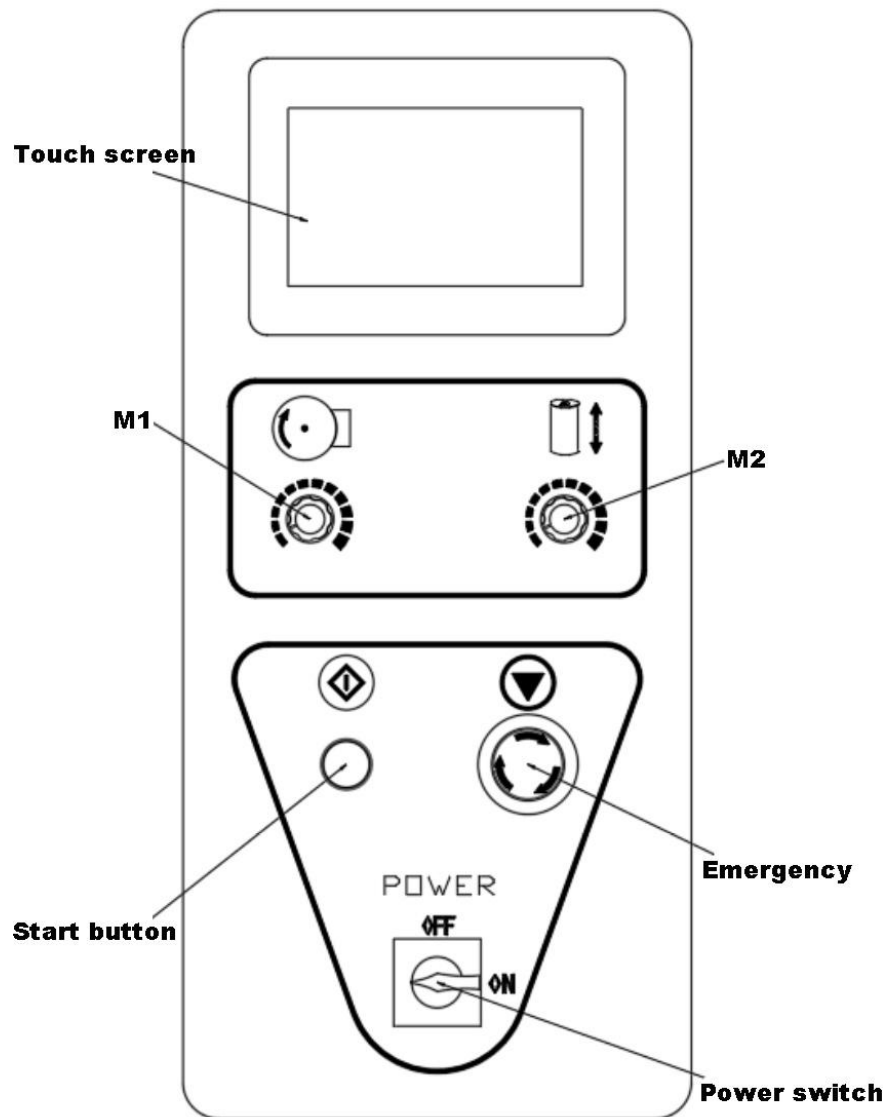

Figure 6

**Speed Controlled by M1, M2 Knob**

- M1: Control the speed of the turntable motor. The speed range 1~ 10 rpm.
- M2: Control the lifting motor speed.

**Start Button has three functions**

- The start of the automatic mode starts
- Resume after emergency stop
- Use/cancel the central reinforcement

**Emergency Stop Button**

Press the emergency stop button to stop the machine immediately. Press the button when any emergency occurred during the packaging process. Turn the emergency stop button clockwise to reset the emergency stop button.

**Power Switch**

- OFF, power off the machine
- ON, power on the machine

## 4. Operator Controls

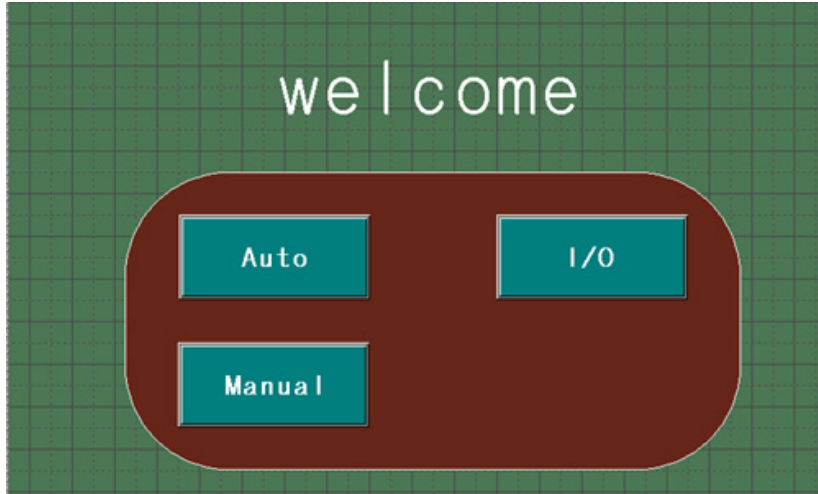

Figure 7 Main menu display

### 4.1 Manual

Press the manual Interface button in the main menu to display the manual operation. (See Figure 8)

#### Carriage up / Carriage down

Manually operate the carriage to move up or down. When this function is pushed, the button will turn green. To pause the operation, simply push the button again. This button may be used in conjunction with the Turntable start button.

#### Turntable start

The Turntable Start button allows you to manually operate the turntable. When this button is pushed, the button will turn green. Pushing the button again will stop the turntable. The button may be used in conjunction with the Carriage up/down button.

#### Reset

Push the Reset button to reset the system operation. The turntable will return to its home position and the carriage will lower to the initial position.

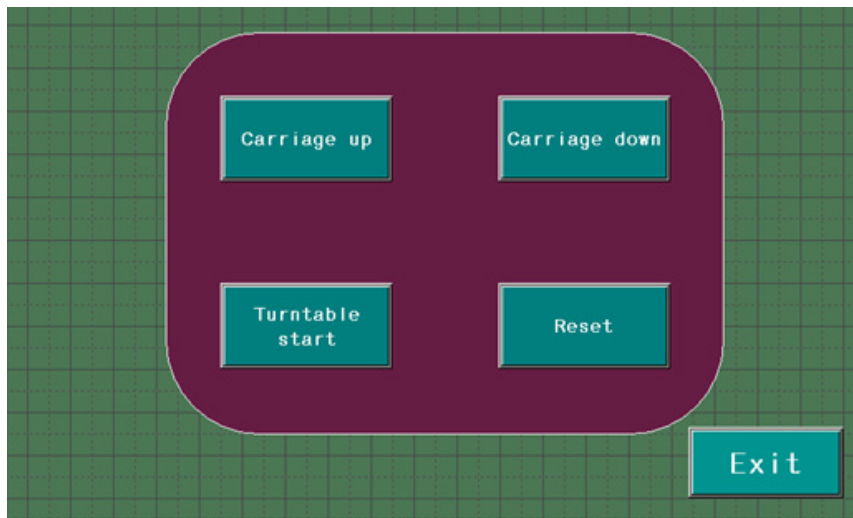

Figure 8 Manual display

#### 4.2 Auto

Press the AUTO button in the main menu to set parameters through the interface shown in figure 9 .

The parameters can be set according to the following packaging requirements: Bottoms Laps, Top Laps, Lifting Time, Strengthening Laps, and electric eye delay. Press the white box to set each parameter through the pop-up numerical keyboard followed by pressing the Enter button.

Once the parameters are set, click the "Save" button on the screen to store the parameters for the assigned group number. A total of five sets of parameters can be stored. To use any of the saved parameters, select the group number. (See Figure 9)

NOTE: The parameters and function settings cannot be changed when the machine is running.

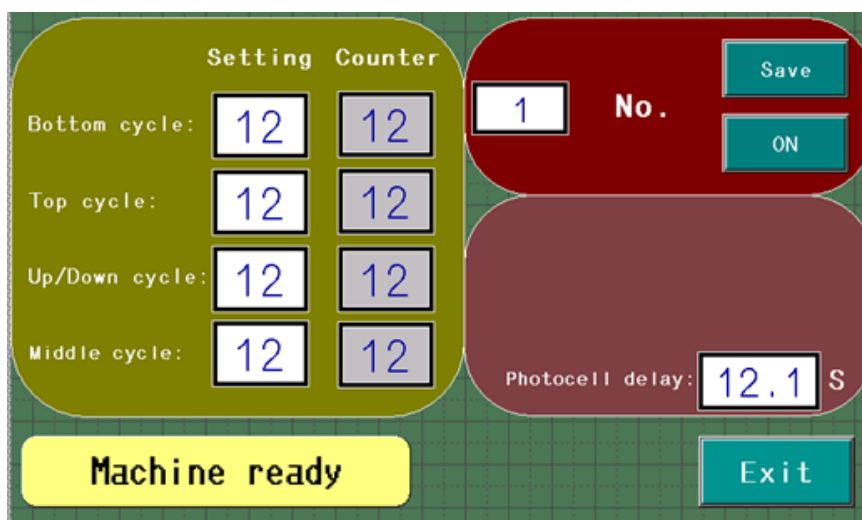

Figure 9 Auto display

### 4.3 Input & Output (I/O)

You can check the status of all the sensors and switches on the I/O interface shown in Figure 10. This display can be used for routine maintenance on the machine. (See Figure 10)

To return to the main menu, press the EXIT button.

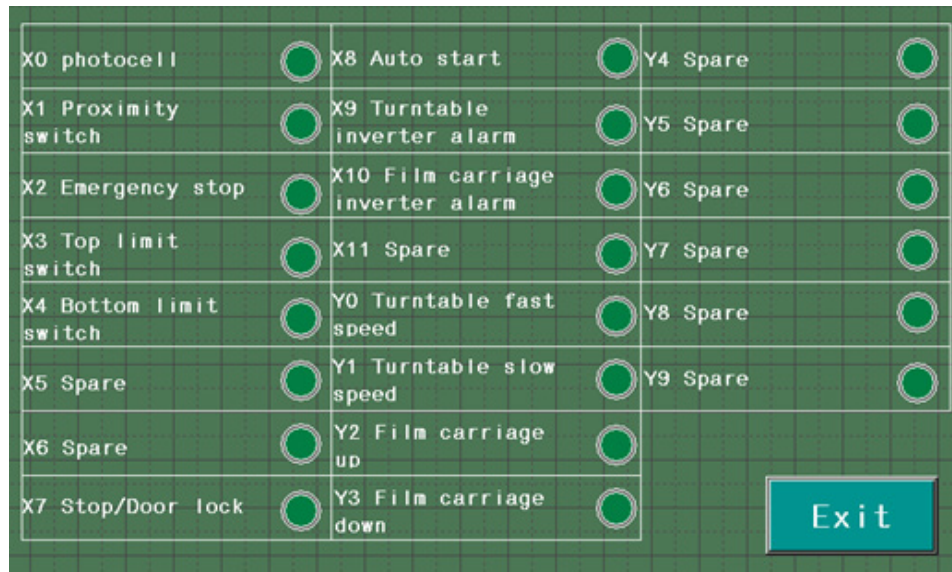
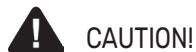

Figure 10 I/O display

### 4.4 Film Loading



CAUTION!

Be sure EMERGENCY STOP is pushed in before threading the film and pulled out when the film is threaded.

1. Load the film roll in the film carriage. (See Figure 11)
2. Follow the film feed diagram and thread the film all the way through the rollers. (See Figure 12)
3. Attach the film securely to the pallet. Tying the end of the film in a knot often helps secure the film to the pallet.
4. Turn the emergency stop switch clockwise and turn the power on.

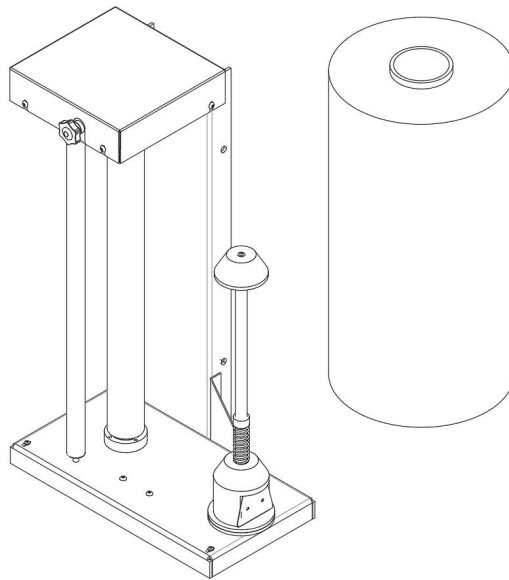

Figure 11

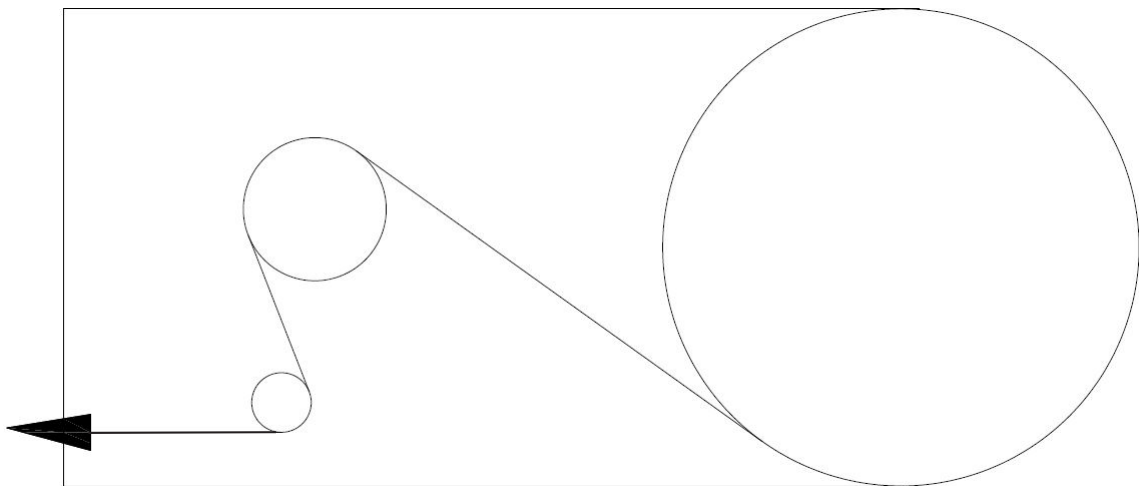

Figure 12

## 4.5 Machine Operation

### Trial run – Normal System Start-up:

1. Place the packaged pallet on the machine turntable.
2. Thread the film as instructed and attach it to the product.
3. Turn the power on.
4. Adjust the sensitivity of the photo switch. The machine is adjusted to the factory setting before delivery.
5. Select either Manual or Auto mode to achieve the user's packaging requirement.
6. Press the START button to initiate cycle.

NOTE: It is recommendwd to try a trail run to become familiar with the various parameters, adjustments, and speed controls.

### Emergency Stop Condition

1. In the event of an emergency, press the STOP button. This cancels the current wrapping cycle and immediately stops the system. Figure 13 will display on the screen.
2. Correct the problem.
3. Turn the STOP button clockwise to reset the stop button and perform the normal system start-up procedure.

NOTE: If the weight of the package exceeds 1,100lbs. , turn the turntable adjustment knob M1 counterclockwise prior to pressing the emergency stop button.

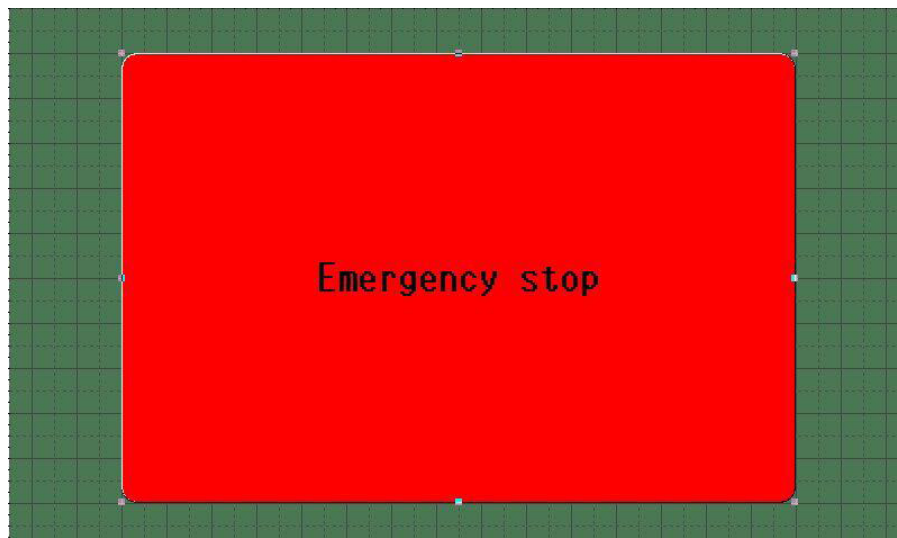

Figure 13



## Operation

1. Load the film roll in the film carriage and thread the film according to figure 12.
2. Turn the power on.
3. Adjust the sensitivity of the photo switch. The machine is adjusted to the factory setting before delivery.
4. Adjust the parameter according to the packing requirements.
5. Trial run: Place the packaged pallet, used for a trial run, on the machine turntable. Adjust M1 & M2 speed controlled knobs to the desired speed. Packaging operation can be adjusted by the multiple parameters to achieve the user's packaging requirement. Once the user is familiar with the various parameters and adjustments, the user is ready to operate the machine.

## 5. Maintenance & Troubleshooting

 CAUTION!

All machine maintenance work must be performed with the power supply disconnected.

1. Keep the machine clean. Use a dry cloth and cleaning agent to clean the machine. Do not use solvent water to clean the machine to prevent rusting.
2. Regularly perform maintenance on the machine every 3 – 6 months; frequency varies with the machine usage. Check for internal dust build up. Check the tightness of the chain and lubricate the chain in routine maintenance inspections.



WARNING!

Make sure that only qualified personnel perform inspection, troubleshooting and part replacement.

 CAUTION!

Disconnect all power, including external control power that may be present before servicing the frequency drive controllers.

Table 2

<b>OPERATING ISSUES</b>	<b>CAUSES</b>	<b>RECOMMENDATIONS</b>
<b>The machine is not powering on</b>	Main Power is turned off.	Check the power going into the machine. Verify that the switch is turned on.
	Machine not plugged into 110VAC outlet.	Verify the voltage going to the machine matches the power supply labels on the power module.
	Faulty power supply	
	Internal battery not charged.	
	PLC Failure	Replace new PLC
	No display on PLC screen	
	Fuse Burn	Replace the fuse
<b>Turntable does not run.</b>	Pallet overweight	Reduce the pallet weight
	Chain falls off	Check the chain transmission mechanism (loosen the chassis screws, remove the turntable cover and check whether the chain and tension are abnormal.
	Loose chain	
	Inverter failure or damage	The output protection of the inverter will flash the fault code on the inverter. Look up the corresponding fault code and troubleshoot method. Replace inverter if damaged.
<b>Film carriage malfunction</b>	Limit switch failure or damage	Overhaul or replace the limit switch
	Photocell failure or damage	Overhaul or replace the photocell
	Loose chain or interference	Overhaul the vertical lifting chain system
	PLC Failure	Replace the PLC
	Carriage Up/Down button is unresponsive	
	Inverter failure or damage	Troubleshoot and replace inverter if damaged
	Motor Failure	Overhaul the lifting motor

# 6. Components & Parts

## Turndtable

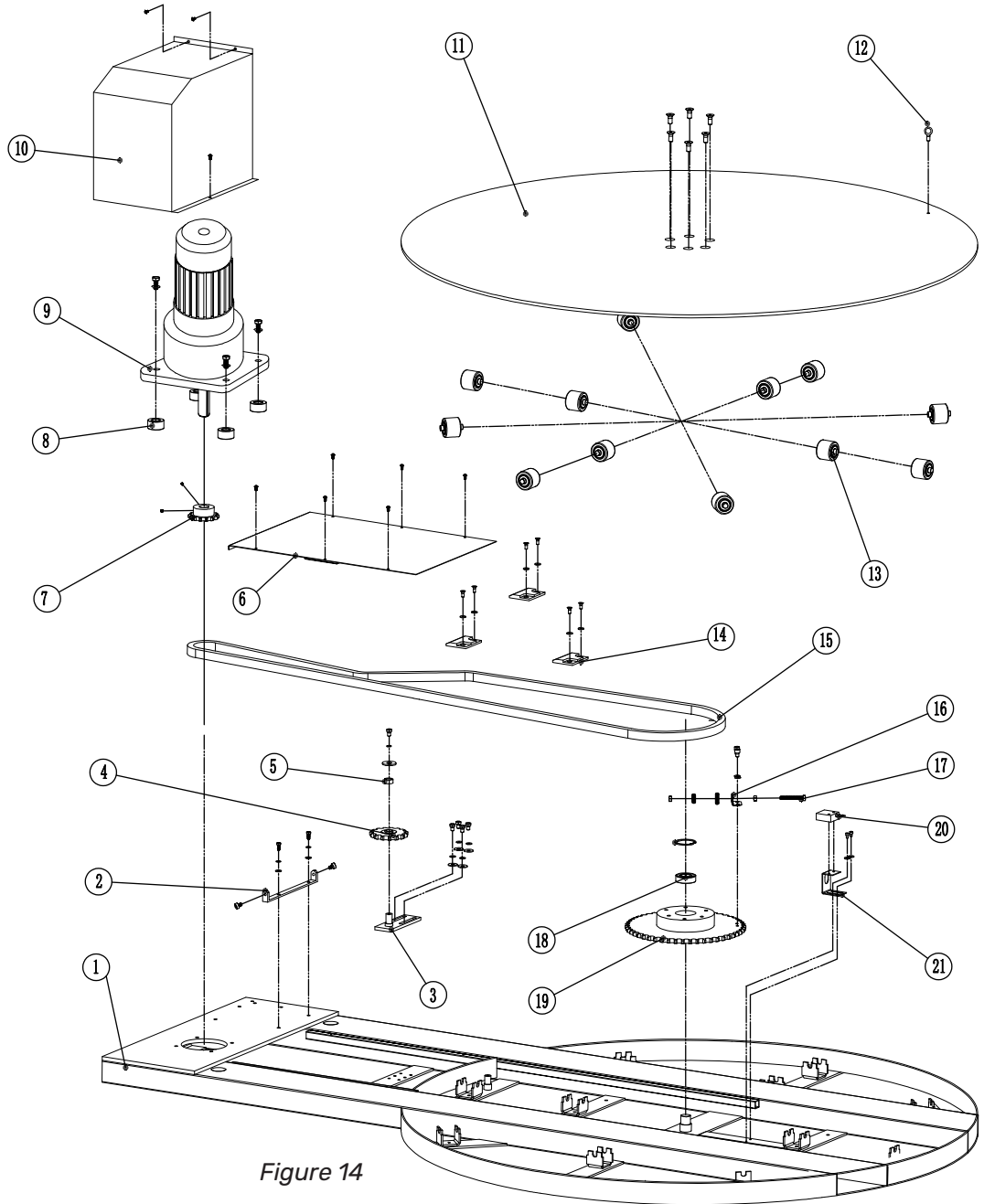

Figure 14

Table 3

<b>Turntable</b>			
<b>No.</b>	<b>Part no.</b>	<b>Description</b>	<b>Qty.</b>
1	XT4505-0100-V1	Turntable base	1
2	XT45N-0101-1	Hinge fixing base	1
3	10000000698-V1	Tension pulley bracket	1
4	XT4505-0129-V1	Tension pulley: 12BZ11	1
5	XT8020-0614	Plastic Spacer	1
6	XT4505-0126-V2	Protection cover	1
7	10000000486G	Motor chain pulley: 12B, 14 teeth	1
8	XT8020-0506	Plain roller	4
9	CV-32-750-30S-UL	Gear Motor	1
10	XT4505-0102-V1	Motor cover	1
11	10000000510-V2	Disc	1
12	GB/T825-1988	Hook M10	1
13	10000000617	Turntable roller	12
14	10000000548	Chain noise reducer	3
15	GB/T1243-1997	Chain 12B 174 keys	1
16	10000000688	Contacting plate holder	1
17	GB/T5783-2000	Hex bolt M8*60	1
18	GB/T276-1994	Deep groove bearing 6205-2Z	1
19	10000000693	Center turntable pulley	1
20	PL-05N	Switch	1
21	XT45N-0110	Switch holder	1

## Film Carriage

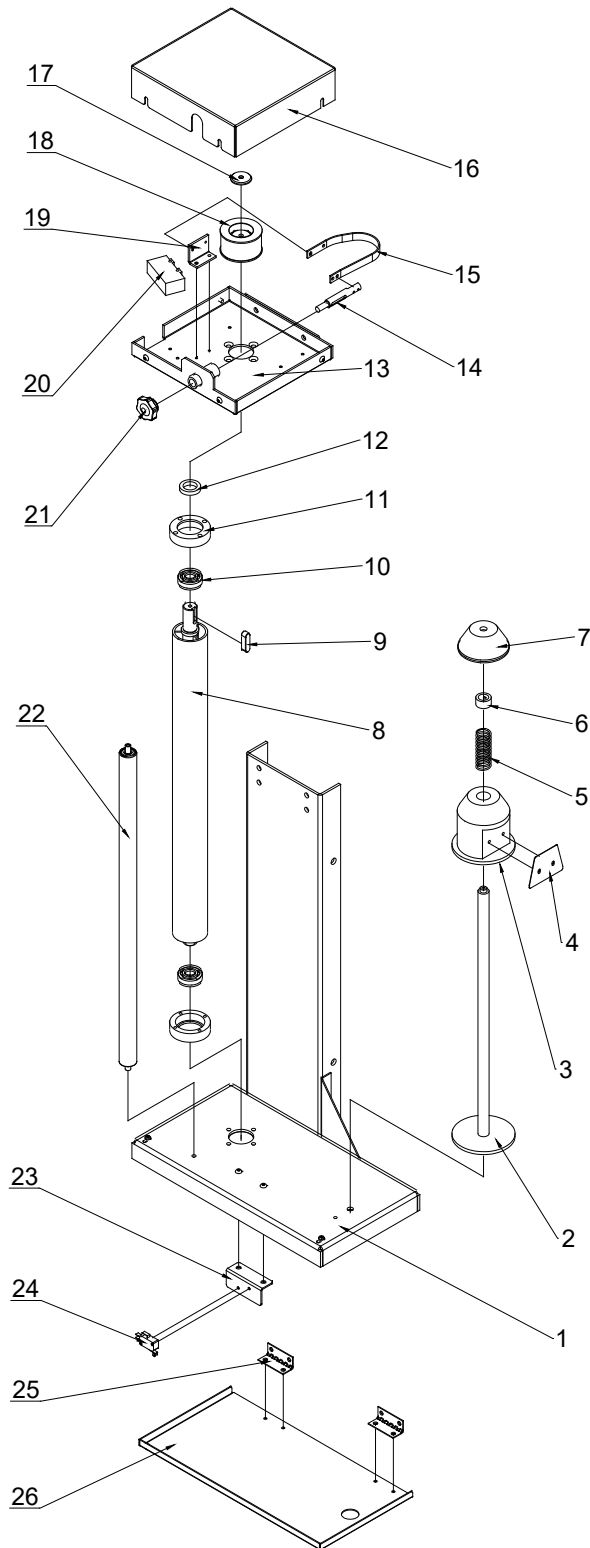

Figure 15

Table 4

<b>Film Carriage</b>			
<b>No.</b>	<b>Part No.</b>	<b>Description</b>	<b>Qty.</b>
1	XT15Z-02-V2	Bottom fixed plate assembly	1
2	XT45M-19	Film roll: welding assembly	1
3	10000000033	Film roll: bottom seat	1
4	10000000035-VI	Spring plate	1
5	10000000030	Spring	1
6	20545000404-V1	Lock ring	1
7	10000000034	Film roll: top seat	1
8	XT45Z-06-V1	Rubber roller unit	1
9	GB/T1096	6*6*25 key	1
10	GB/T276	Bearing 6004	2
11	XT45M-12-V3	Rubber roller bearing seat	2
12	XT4508A-0205	Lock sleeve	1
13	XT45Z-010-V2	Film carriage top plate	1
14	XT45Z-11-V1	Brake shaft	1
15	XT45Z-11-1	Rubber belt 218L*12W*2T mm	1
16	XT45Z-03-V1	Top film carriage cover	1
17	XT45Z-09	Shaft lock ring	1
18	10000000046	Tension friction wheel	1
19	XT45Z-10-V1	Belt holder	1
20	FR-2MX	Photocell	1
21	M8X20	Star knob	1
22	XT45M-14	Guide roller	2
23	XT45Z-16	Swith install plate	1
24	KW3-0Z-2	Microswitch w/ wheel	1
25	QB/T3876	Hinge: 50 x 38	2
26	XT45Z-15-V3	Safety plate	1

Tower and Lift

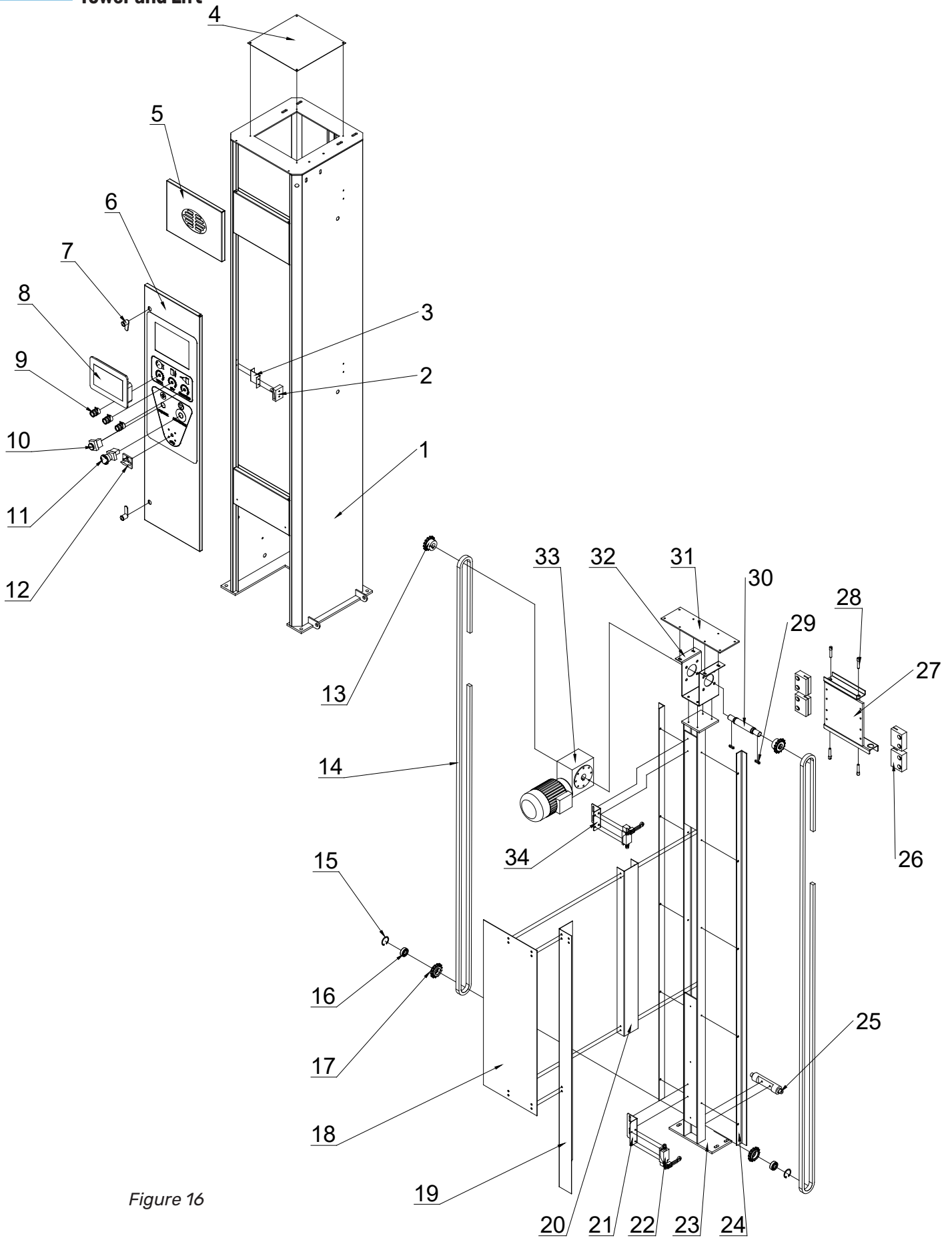

Figure 16



Table 5

<b>Tower and Lift Assembly</b>			
<b>No.</b>	<b>Part No.</b>	<b>Description</b>	<b>Qty.</b>
1	XT4505-0201-V2	Tower body	1
2	Z15G 1703 15A	Door safety switch	1
3	XT4505-0206	Z type holder	1
4	XT4505-0204	Tower body top cover	1
5	XT4505-0203	Tower body top protection plate	1
6	XT4515-02-002	Door	1
7		Locker	2
8	HMIGXU3500	Touch screen (Schneider)	1
9	RV24YN 205 4.7K/2W + MF-A03	Potentiometer + Knob	3
10	HBDS1-AWY-11	Start button	1
11	K22-81R	Emergency stop switch	1
12	ULW26GS-20/04-1	Power switch	1
13	10000000549	Lifting motor chain wheel: 14 teeth	2
14	08B P12.7	Chain 08B (12.7), 314 joint	2
15	GB/T893.1 D35	Locking ring 35	2
16	GB/T276	Bearing: 6202-zz	2
17	XT4505S-0113	Chain wheel: 08b 14 teeth	2
18	XT4505S-0110-V2	Electrical housing	1
19	XT4505S-0115-V2	L Channel bracket	1
20	XT4505S-0105	Electrical component storage	1
21	XT4505S-01-17-V2	Bottom limit switch seat	1
22	TZ-8108	Limit switch	2
23	XT4505S-010702-V4	Inner tower assembly	1
24	XT4505S-0104	Guide rail	2
25	XT4505S-0103G	Sliding block	4
26	XT4505S-0102-V1	Drive shaft	1
27	XT4505S-0109-V1	Connection board assembly	1
28	XT4505S-0111	Screw	4
29	GB/T1095	Key 6*6*25	2
30	XT4505S-0101	Shaft	1
31	XT4505S-0108	Top lifting board	1
32	XT4505S-010701	Motor seat	1
33	NMRV050	Lifting assembly	1

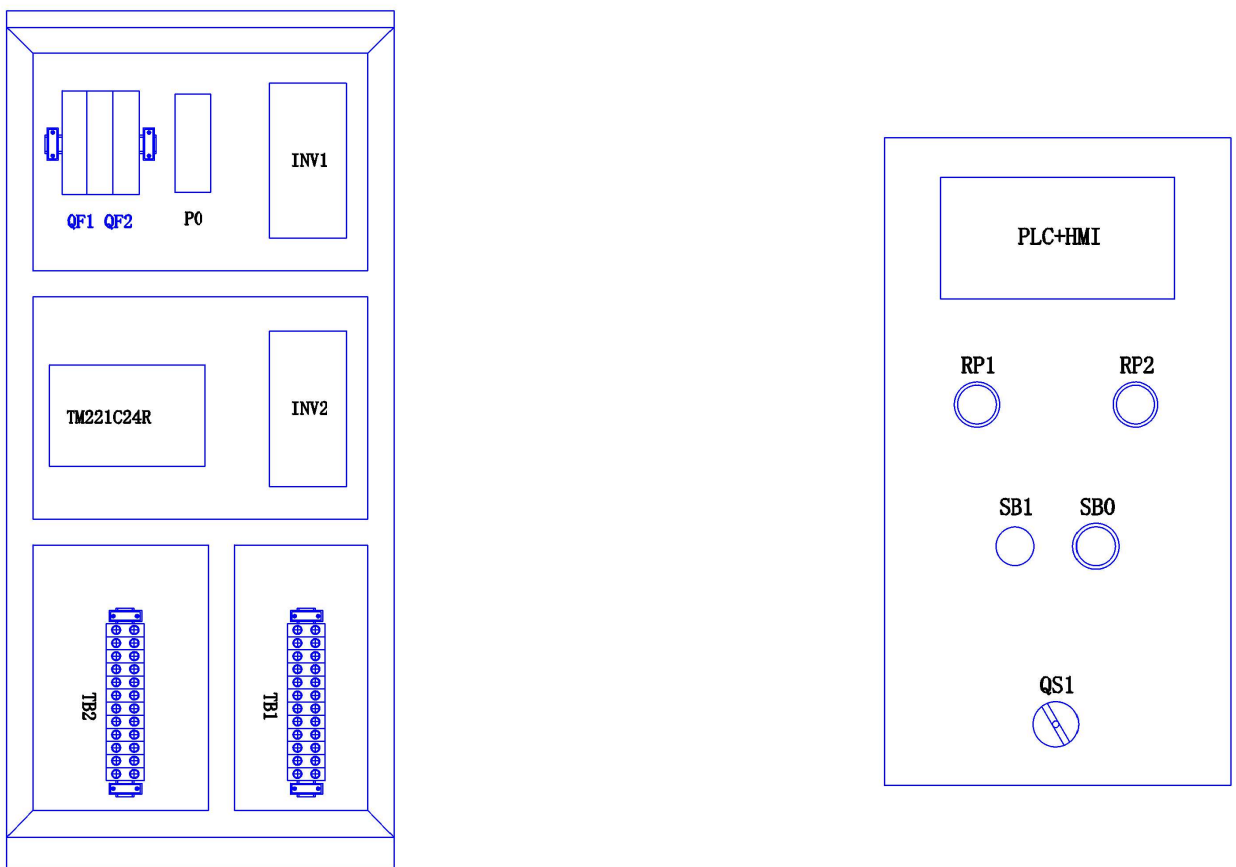

Figure 17

Table 6

Part no.	Description	Specification	Qty.
QF1	Circuit Breaker	DZ47-63 2P C16A	1
QF2	Circuit Breaker	HB1Z-63 1P C2A	1
P0	Power supply	LRS-50-24	1
INV1	Turntable inverter	ATV12H075F1110V 0.75KW	1
INV2	Lift inverter	ATV12H037F1 110V 0.4KW	1
TM221C24R	PLC	TM221C24R	1
TB1	Connector	TD1520	1
TB2	Connector	TD1520	1
PLC+HMI	Touch screen	HMIGXU3500	1
RP1	Potentiometer	RV24YN 205 4.7K/2W	1
RP2	Potentiometer	RV24YN 205 4.7K/2W	1
SB1	Start Button	HBDS1-AWY-11	1
SB0	Emergency button	K22-81R	1
QS1	Power isolation switch	ULW26GS-20/04-1	1

Electrical Diagram

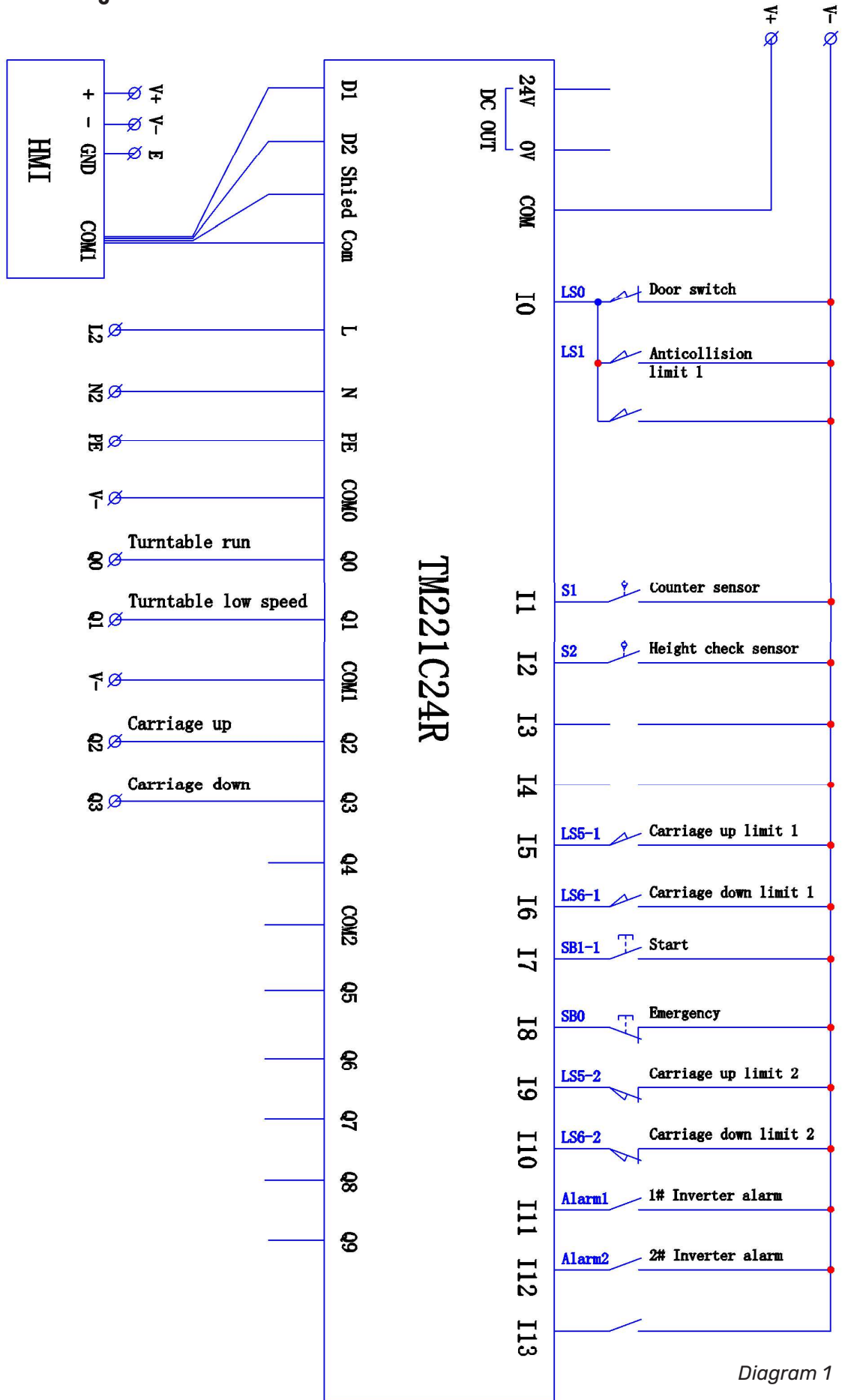

Diagram 1

Power Supply: AC110V, 60 Hz

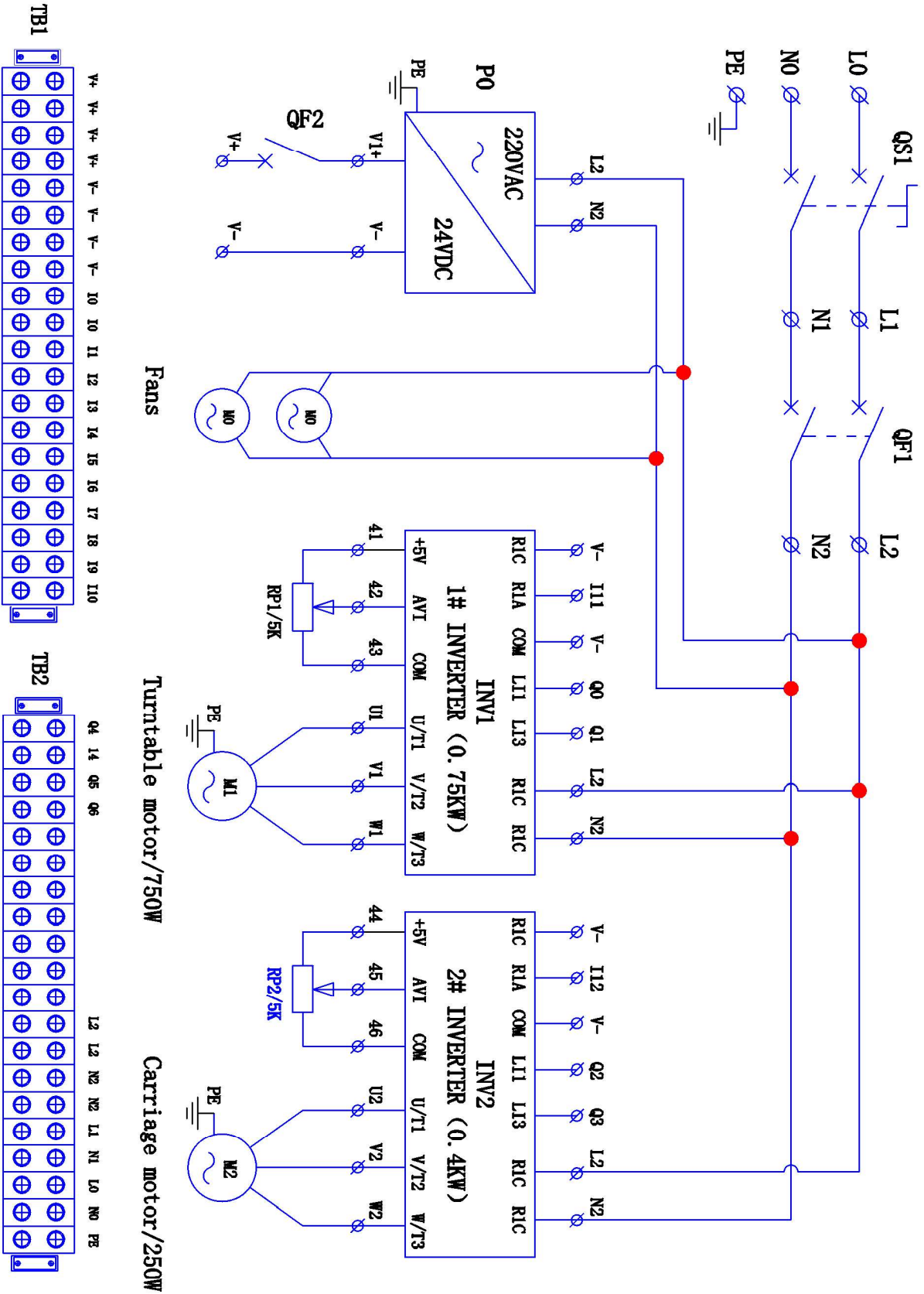

Diagram 2



**WE CAN SUPPLY THAT.®**  
**1,000,000-PLUS PRODUCTS. INDUSTRIAL-STRENGTH SERVICE.**