

Assembly Instructions

Customer Service
US: 1-800-645-2986

Instrucciones de Ensamblaje

Servicio de atención al Cliente
US: 1-800-645-2986

Directives d'assemblage

Service à la clientèle
Canada: 888-645-2986

Hanging Clamps For Blueprint Storage Rack

Model no. 316108, 316109, 316110

Instructions

1. Loosen wing knobs on top of clamp turning counter clockwise. Pull jaws out from "U" channel and the clamp will open.

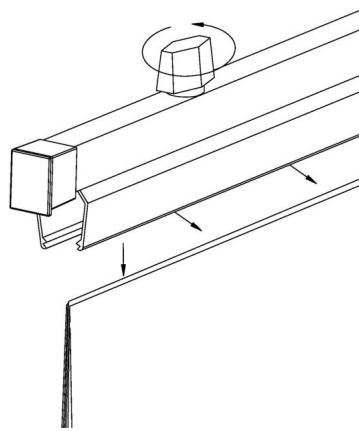

2. Insert files into clamp jaw and hand tighten wing knobs until the files are secure. Print clamp shown is a cut-away diagram to show the internal mechanism.

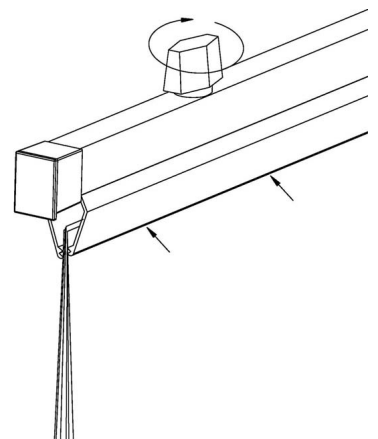

Installation

1. Make certain that the pivot bracket is installed properly on the rack with the spring on top.

2. Insert clamp clip (on top of clamp) as shown at an angle and push forward and then down to horizontal.

3. Once completely inserted on the hanger, gently pull the hanger away from the rack until the rear knob on the clamp pulls over the mounting plate.

