

Fully Automatic Low Profile Pallet Wrapper

User Manual

Model NO: 238509

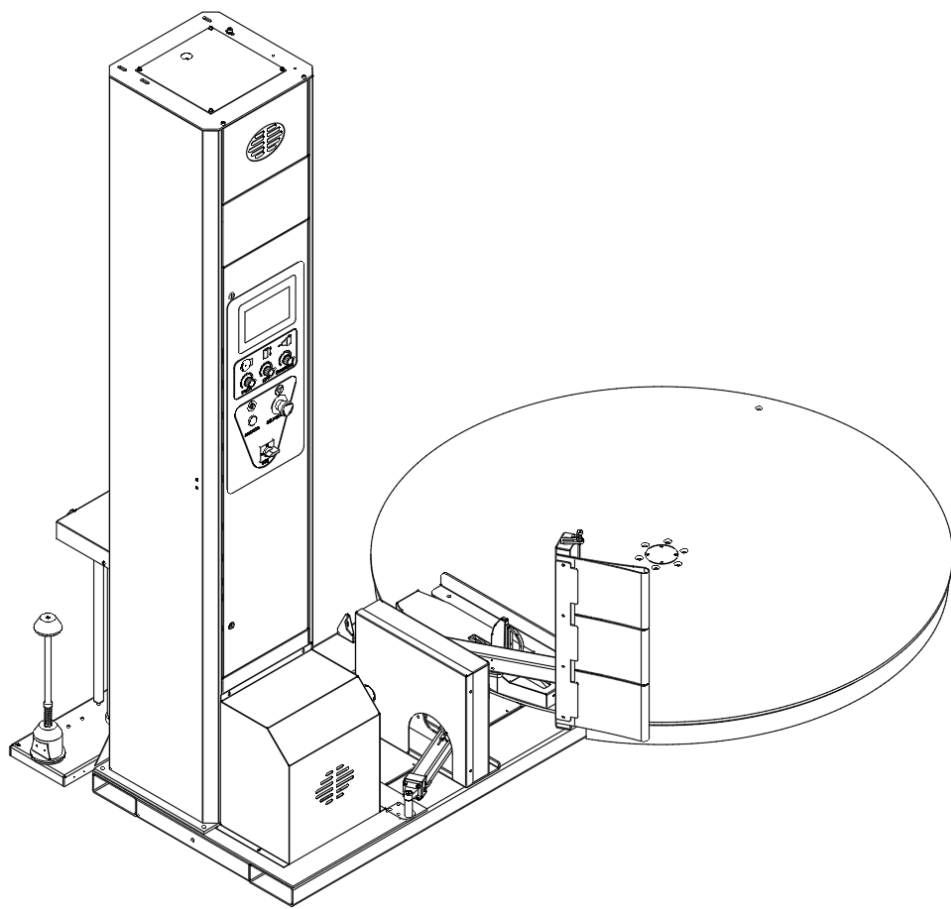

Content

1. System Specification	1
2. System Set-up.....	3
2.1 Machine Set-up	4
2.2 Installation.....	5
3. Control Panel Buttons	7
4. Operator Controls	9
4.1 Manual	9
4.2 Auto.....	10
4.3 Input & Output (I/O)	11
4.4 Film Loading	12
4.5 Machine Operation	13
5. Maintenance & Troubleshooting	15
6. Components & Parts	17

Machine Dimension

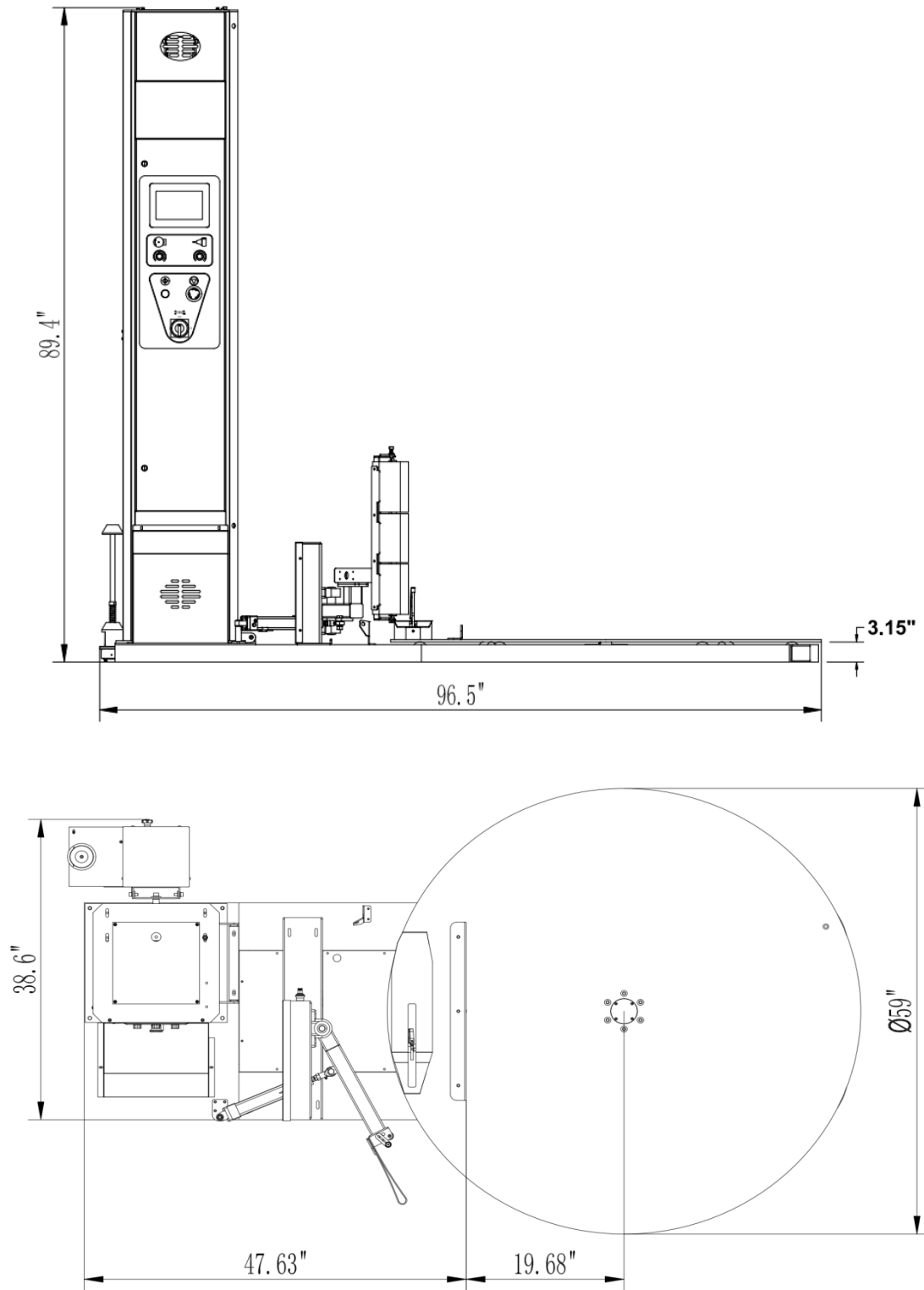

Figure 1

1. System Specification

Machine Dimension

(See Figure 1)

Length	96.5"
Width	59"
Height	89.4"
Turntable Diameter	59"
Turntable Height from Floor	3.15"
Wrapping Height	83"
Operation Space	97" x 60" x 90"
Maximum Load Size	47" x 31" x 82"

Specification

- 120V 60HZ Single-Phase
- Power Supply: 1000W
- Air: 0.6-0.7Mpa

Turtable System

- 13RPM turntable maximum speed
- 4400 lbs turntable maximum load capacity
- 1-13 rounds/minute
- Clockwise rotating turntable direction

Film Delivery System

- Infinite/Manual Tension Adjustment
- 10" Diameter Roll Capacity
- 3" inner film roll diameter
- 20" Roll width Capacity

Machine Features

- Programmable logic controller (PLC) user interface
- 6 Modes: that's 5 automatic modes+1 manual mode
- The film carriage adopts close loop self-adjusting technology, to ensure each package is evenly wrapped
- Allowable package weight (22lbs-4400lbs)
- SAFETY: The machine has an emergency stop button & sensor underneath the film carriage. Once an object is detected underneath the moving film carriage, the machine will stop.
- The machine is equipped with automatic film attaching and cutting mechanism. It can feed and cut the film automatically, no operator required.
- The interval between 2 wrapping operations is required to more than 3 minutes.

CAUTION!

When servicing drive and controllers, they may be exposed components with housing or protrusions at or above the line potential. Extreme care should be taken to protect against shock.

The user is responsible for conforming to all applicable code requirements with respect to grounding requirements. Do NOT use extension cords to operate the equipment.

Disconnect AC input power when the machine is not in use and before checking components, performing maintenance, cleaning up and. Do NOT connect or disconnect wires and connectors while power is applied to the circuit.

Always plug into a grounded outlet with the rated voltage.

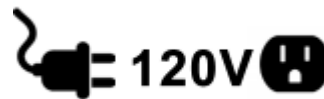

WARNING!

Loose clothing must NOT be worn while the machine is in operation. Stay clear of moving parts while the machine is running.

- For industrial and indoor use only.
- Do not immerse in water.
- To Reduce the Risk of Electric Shock and Injury to Persons, Disconnect from Power Supply Before Servicing and Opening.
- To provide continued protection against risk of electric shock, connect to properly grounded outlets only.
- Any servicing should be performed by an authorized service representative AND that the product has no user serviceable parts.
- The door lock can only be opened by authorized service personnel.

2. System Set-up

Machine Placement

Place the semi-automatic Stretch Wrap Machine close to an area where you will be wrapping your pallet loads. Refer to figure 2 to insure the machine meets the minimum clearance space requirements. Make sure that there is sufficient room to load/unload the machine and that you do not stretch the wiring cable. Remember, you will need to provide electrical service to 120 VAC, 9.1-AMP outlet. (see Figure 2)

Floor Weight Bearing Tolerance

The floor must be able to bear the weight of the machine, the weight of the maximum load, plus a safety factor. The floor must also be able to tolerate the stress of the machine operation. If the truck will operate on the same weight bearing area, add the weight of the trucks to the weight bearing stress tolerance requirement.

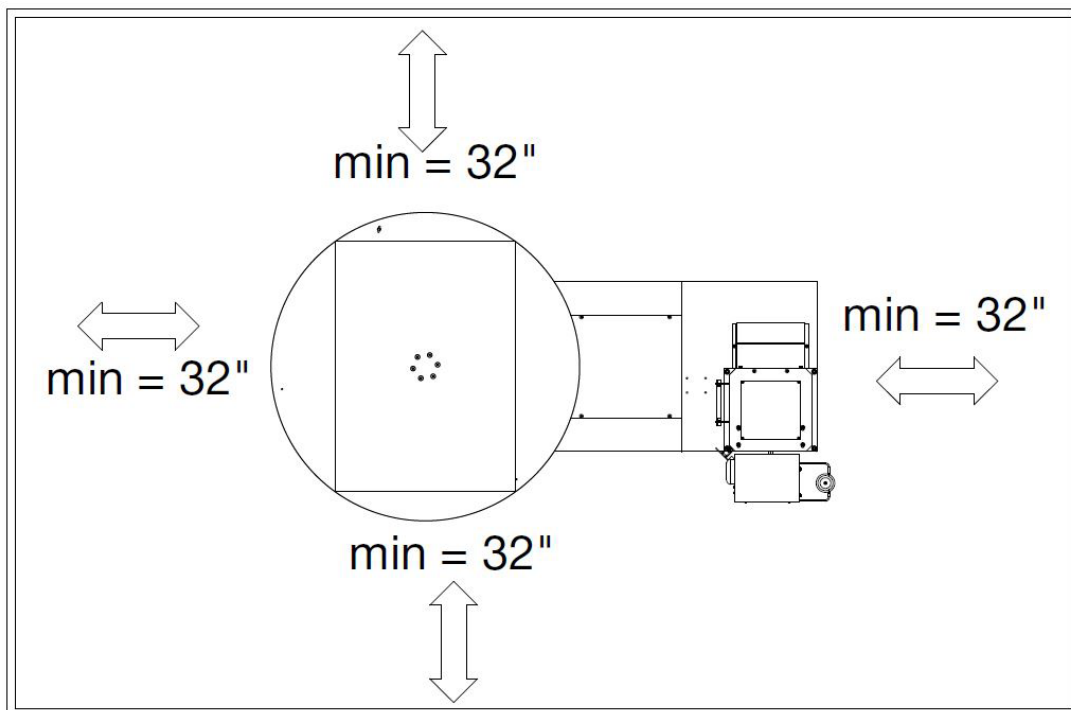

Figure 2

2.1 Machine Set-up

1. Place the crated machine close to the designated wrap area. Remove all shipping fasteners holding the machine to the pallet. The machine may be crated with the tower tilted down the motor cover front carriage roller removed for shipping purpose.
2. Place forks of the forklift through the tubes provided at the rear base of the module, remove the machine from crate and place it at the designated wrap area.
3. Check all internal connections to ensure there is no loose/disconnected electrical wiring.
4. Connect the motor wiring and sensor leads according to the corresponding wire numbers.
5. If the OPTIONAL ramp (Model NO: 412410) is purchased: Select a ramp position illustrated below. The ramp can be positioned anywhere in a 180 rotation around the front of the turntable. There should be a 1/4" gap between the turntable and the ramp. The ramp should be fully supported by the floor.
(See Figure 3)

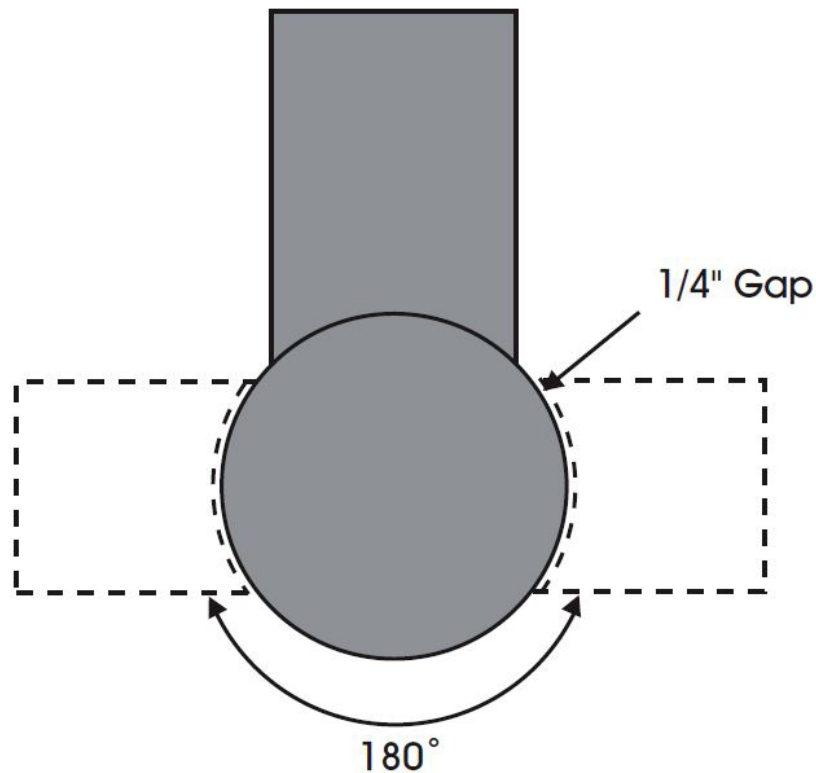

Figure 3

2.2 Installation

NOTE: Installation requires two people



CAUTION

Be careful when standing on the turntable during the installation, as it may turn when rotational force is applied.

1. Raise the tower upright safely with two people
2. Tighten the screws between the tower and the turntable base (See Figure 4)
3. Screw the film carriage into the post (See Figure 5)
4. Connect to the power supply and perform a ground test before using the machine.

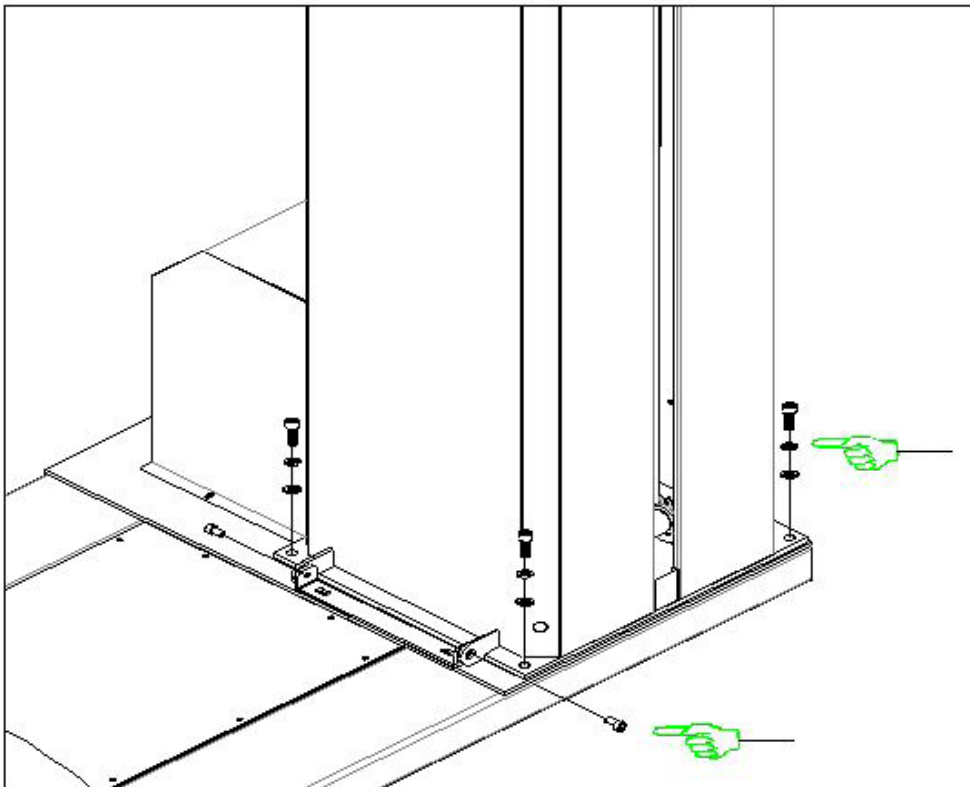

Screw the set of **(4)** screws, washers, and lock washers through the tower and into the turntable base securely. **(M10 x 20 screw)**

Screw the set of **(2)** screws connecting the tower and turntable **(M8 x 10 screw)**

Figure 4

Mount the film carriage
onto the post by fastening a
set of (2) screws.
(M8 x 20 screw)

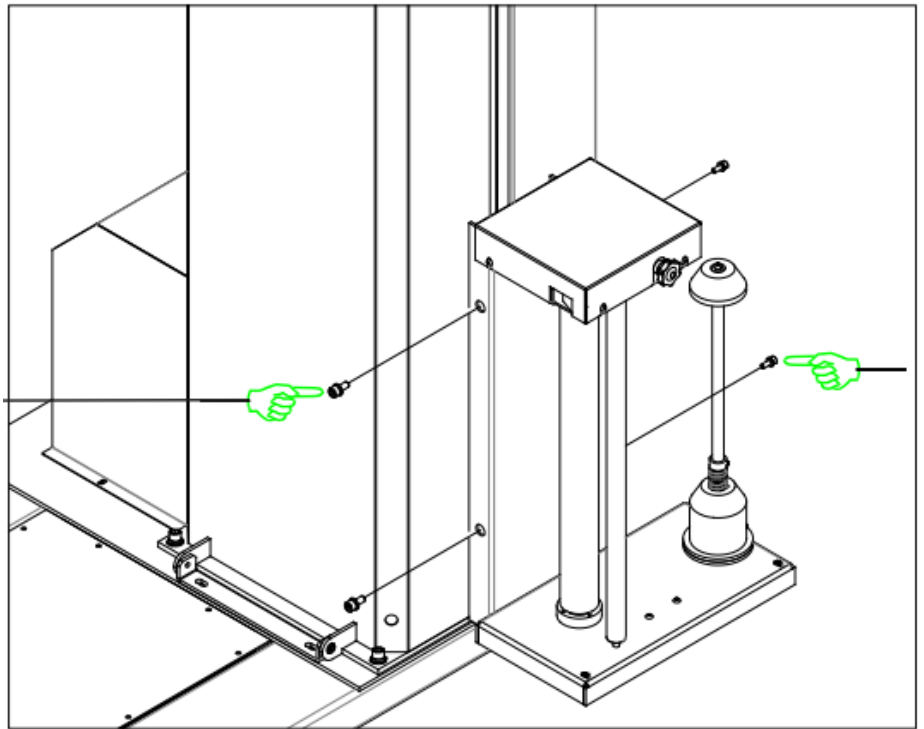

Figure 5

3. Control Panel Buttons

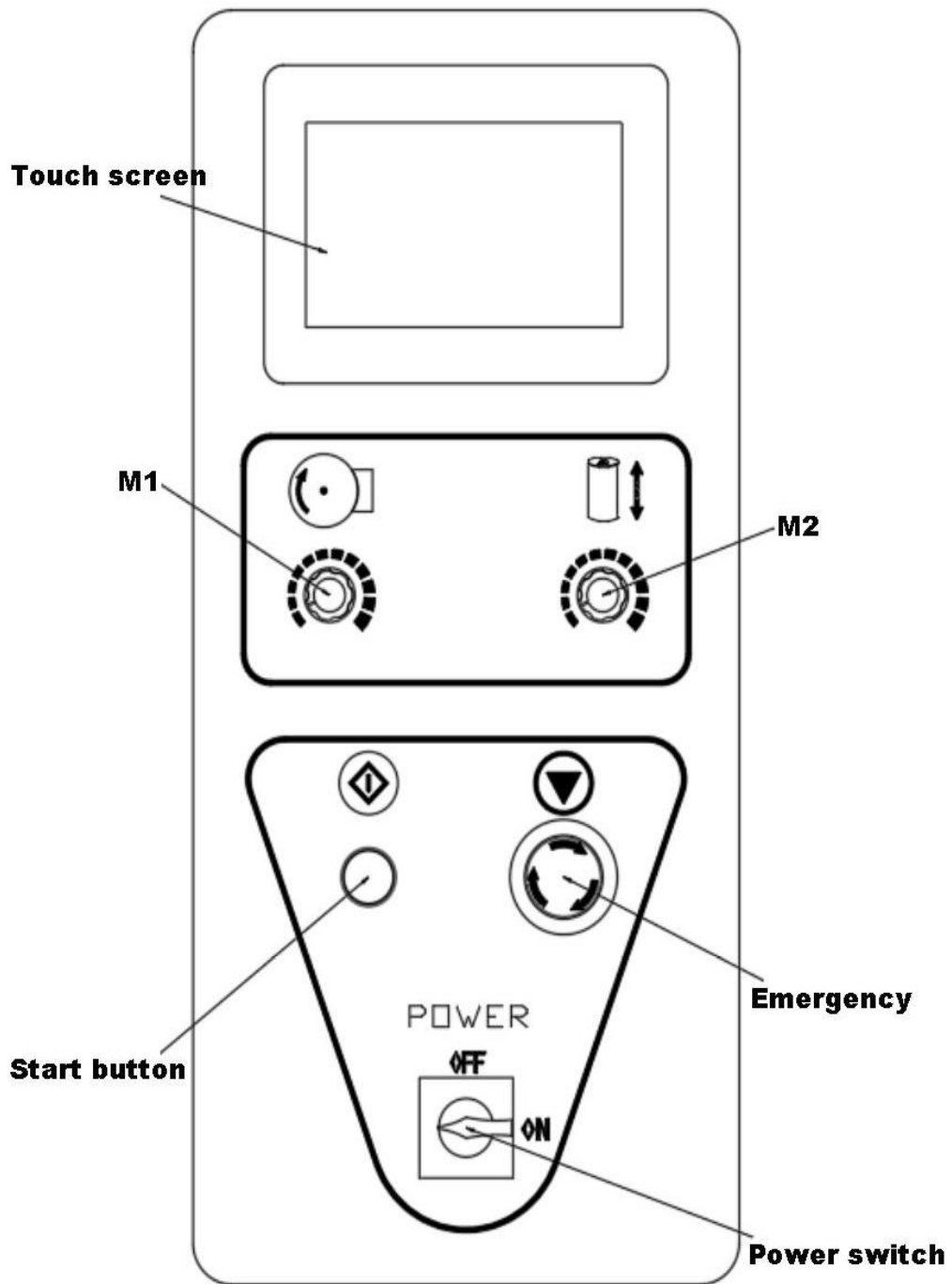

Figure 6

Speed Controller by M1, M2 knob

M1: Control the speed of the turntable motor. The speed range 1-10 rpm.

M2: Control the lifting motor speed

Start Button has three functions

The start of the automatic mode starts

Resume after emergency stop

Use/Cancel the central reinforcement

Emergency Stop Button

Press the emergency stop button to stop the machine immediately. Press the button when any emergency occurred during the packaging process. Turn the emergency stop button clockwise to reset the emergency stop button.

Power Switch

OFF, Power off the machine

ON, Power on the machine

4. Operator Controls

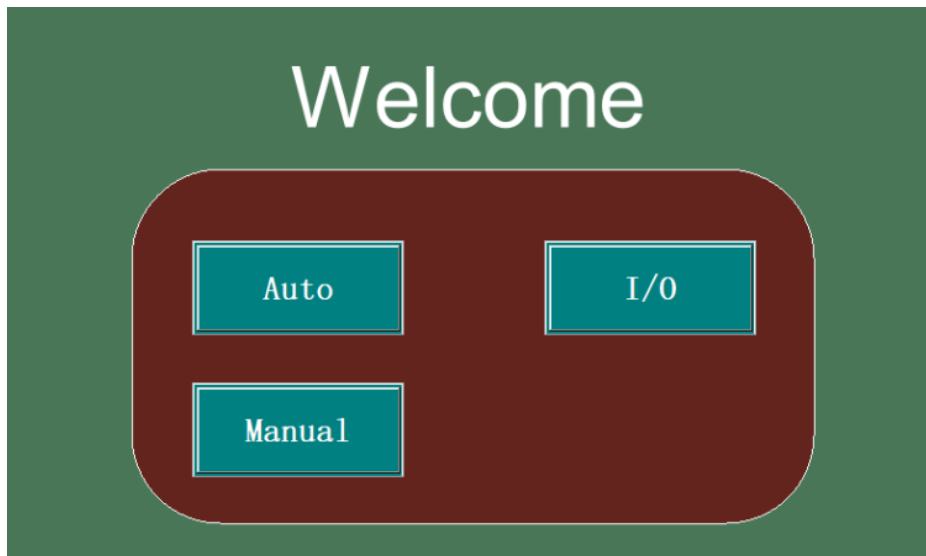

Figure 7 Main Menu Display

4.1 Manual

Press the manual interface button in the main menu to display the manual operation. (See Figure 8)

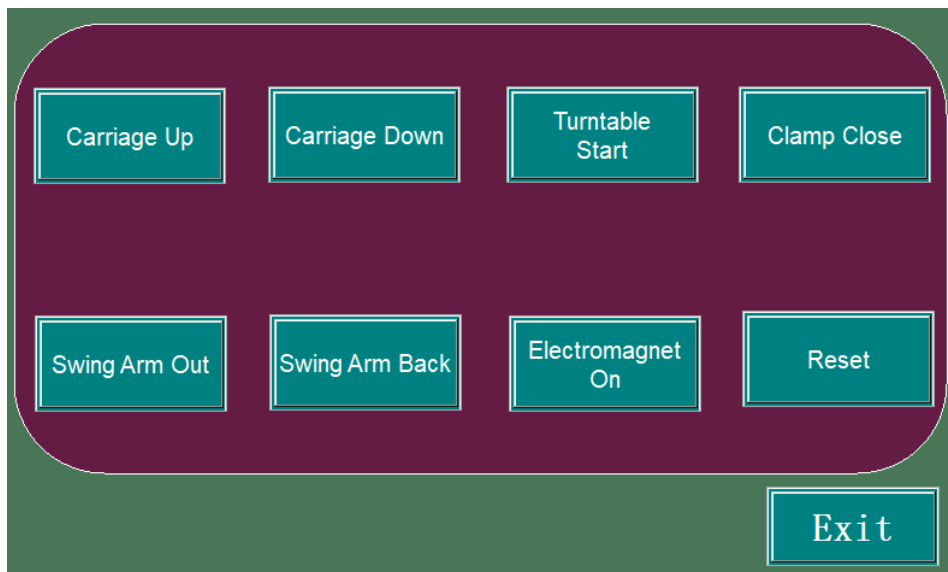

Figure 8 Manual Display

Carriage up/Carriage down

Manually operate the carriage to move up or down. When this function is pushed, the button will turn green. To pause the operation, simply push the button again. This button may be used in conjunction with the turntable start button.

Turntable Start

The turntable Start button allows you to manually operate the turntable. When this button is pushed, the button will turn green. Pushing the button again will stop the turntable. The button may be used in conjunction with Carriage up/down button.

Clamp Close

Manually close or open the film clamp device. When this button is pushed, the button will turn green and display as "Clamp Open". Push the button again, the clamp will open.

Swing Arm Out/Swing Arm Back

Manually operate the swing arm to move closer and further from the pallet.

Electromagnet ON

Manually release film tension from the film carriage. When this button is pushed, the button will turn green.

Reset

Push the Reset button to reset the system operation. The Turntable will return to its home position and the carriage will lower to the initial position.

4.2 Auto

Press the AUTO button in the main menu to set parameters through the interface shown in figure 9.

The parameters can be set according to the following packaging requirements: Bottom laps, Top laps, lifting time, strengthening laps, film cutting time and electric eye delay. Press the white box to set each parameter through the pop-up numerical keyboard followed by pressing the Enter button.

Once the parameters are set, click the "Save" button on the screen to store the parameters for assigned group number. A total of five sets of parameters can be stored. To use any of the saved parameters, select the group number. (See Figure 9)

NOTE: The parameters and function settings cannot be changed when the machine is running.

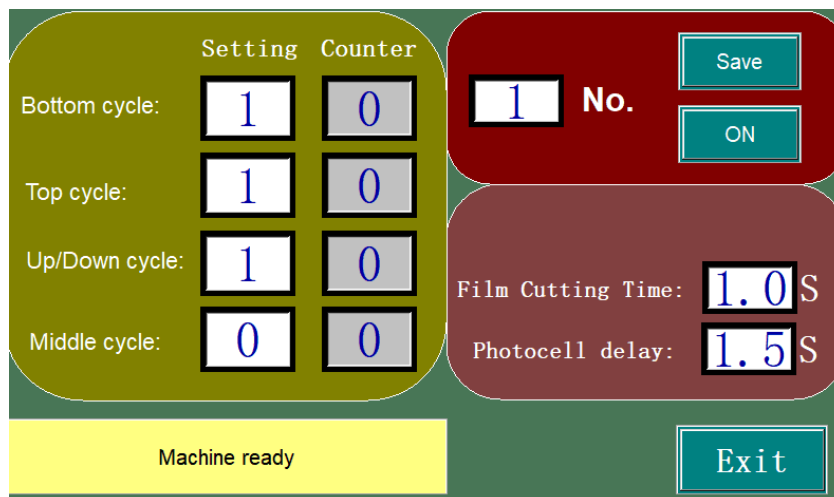

Figure 9 Auto Display

4.3 Input & Output (I/O)

You can check the status of all sensors and switches on the I/O interface shown in Figure 10. This display can be used for routine maintenance on the machine. (See Figure 10 & 11)

To return to the main menu, press the EXIT button.

X0 Photocell	<input type="checkbox"/>	X10 Emergency	<input type="checkbox"/>	X20 Swing Arm End Position	<input type="checkbox"/>
X1 Proximity switch	<input type="checkbox"/>	X11 Carriage up limit 2	<input type="checkbox"/>	X21 Spare	<input type="checkbox"/>
X2 Height sensor	<input type="checkbox"/>	X12 Carriage down limit 2	<input type="checkbox"/>	X22 Spare	<input type="checkbox"/>
X3 Press up limit	<input type="checkbox"/>	X13 Turntab inverter alarm	<input type="checkbox"/>	X23 Spare	<input type="checkbox"/>
X4 Press down limit	<input type="checkbox"/>	X14 Carriage inverter alarm	<input type="checkbox"/>	X24 Spare	<input type="checkbox"/>
X5 Carriage up limit 1	<input type="checkbox"/>	X15 Pre-stretch inverter alarm	<input type="checkbox"/>	X25 Spare	<input type="checkbox"/>
X6 Carriage down limit 1	<input type="checkbox"/>	X16 Swing Arm Original Position	<input type="checkbox"/>		
X7 Auto start	<input type="checkbox"/>	X17 Swing Arm Middle Position	<input type="checkbox"/>		

Figure 10 I/O display

Y0 Turntable fast speed	<input type="checkbox"/>	Y10 Film Carriage Slow	<input type="checkbox"/>	
Y1 Turntable slow speed	<input type="checkbox"/>	Y11 Swing Arm Out	<input type="checkbox"/>	
Y2 Film carriage up	<input type="checkbox"/>	Y12 Swing Arm Back	<input type="checkbox"/>	
Y3 Film carriage down	<input type="checkbox"/>	Y13 Spare	<input type="checkbox"/>	
Y4 Pre-stretch motor	<input type="checkbox"/>	Y14 Clamping	<input type="checkbox"/>	
Y5 Press unit up	<input type="checkbox"/>	Y15 Film Cutting Start	<input type="checkbox"/>	
Y6 Press unit down	<input type="checkbox"/>	Y16 Electromagnet	<input type="checkbox"/>	
Y7 Spare	<input type="checkbox"/>	Y17 Spare	<input type="checkbox"/>	

Figure 11 I/O display

4.4 Film Loading

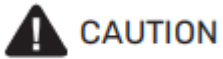

Be sure EMERGENCY STOP is pushed in before threading the film and pulled out when the film is threaded.

1. Load the film roll in the film carriage (See Figure 12)
2. Follow the film feed diagram and thread the film all the way through the rollers (See Figure 13)
3. Attach the film securely to the film clamp and leave 50-100mm longer than the clamp (See Figure 14)
4. Turn the emergency stop switch clockwise and turn the power on.

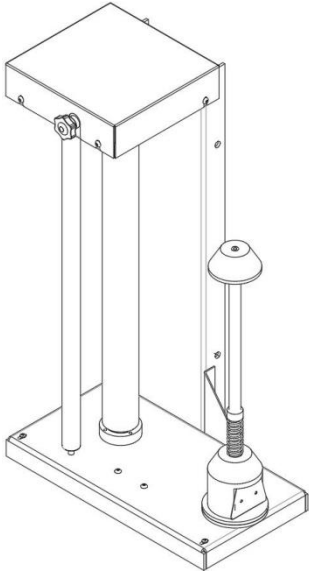

Figure 12

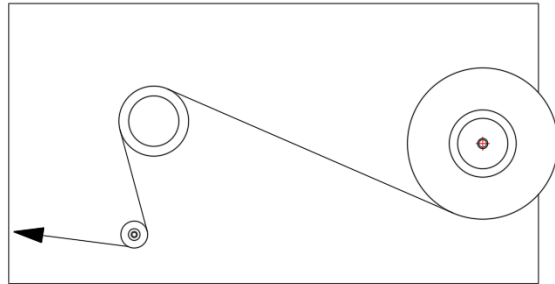

Figure 13

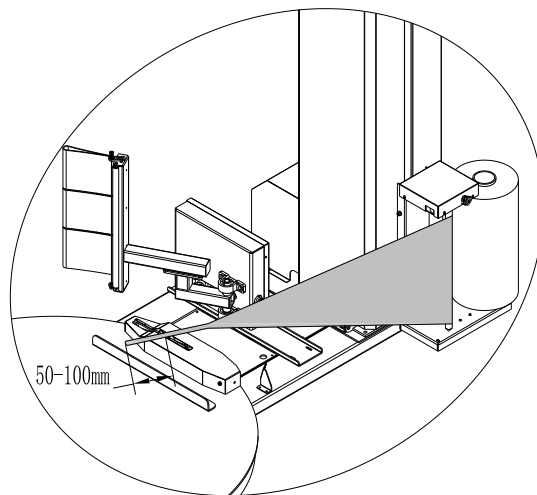

Figure 14

4.5 Machine Operation

Trial run-Normal System Start-Up:

1. Place the Packaged pallet on the machine turntable until the positioning stopping plate touch.
2. Turn the power on
3. Thread the film as instructed and attach it to the film clamp.
4. Adjust the sensitivity of the photo switch. The machine is adjusted to the factory setting before delivery.
5. Push "Start" button on control panel or "ON" on remote controller to initiate cycle.
6. Push "E-Stop" or "OFF" on the remote controller to stop machine running.

NOTE: It is recommended to perform a trial run in order to become familiar with the various parameters, adjustments, and speed controls.

Emergency Stop Condition.

1. In the event of an emergency, press the STOP button. This cancels the current wrapping cycle and immediately stops the system. Figure 15 will display on the screen.
2. Correct the problem.
3. Turn the STOP button clockwise to reset the stop button and perform the normal system start-up procedure.

NOTE: If the weight of the package exceeds 1,100lbs, turn the turntable adjustment knob M1 counterclockwise prior to pressing the emergency stop button.

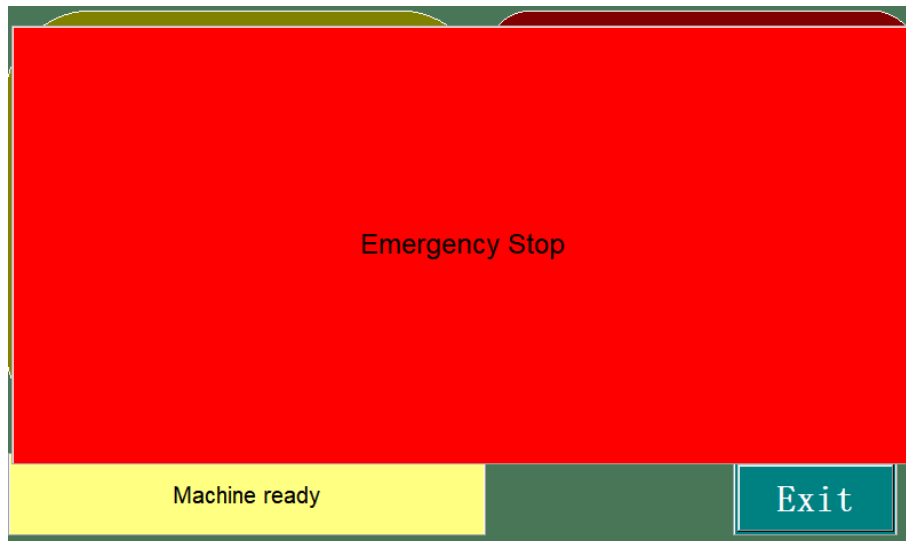

Figure 15

Operation

1. Load the film roll in the film carriage and thread the film according to Figure 13
2. Turn the power on.
3. Attach the film to film clamp according to Figure 14
4. Adjust the sensitivity of the photo switch. The machine is adjusted to the factory setting before delivery.
5. Adjust the parameter according to the packing requirements.
6. Trial run: Place the packaged pallet, used for a trial run, on the machine turntable. Adjust M1 & M2 speed-controlled knobs to the desired speed. Packaging operation can be adjusted by the multiple parameters to achieve the user's packaging requirement. Once the users is familiar with the various parameters and adjustments, the user is ready to operate the machine.

5.Maintenance & Troubleshooting



All machine maintenance work must be performed with the power supply disconnected.

1. Keep the machine clean. Use a dry cloth and cleaning agent to clean the machine. Do not use solvent water to clean the machine to prevent rusting.
2. Regularly perform maintenance on the machine every 3-6 months; Frequency varies with the machine usage. Check for internal dust build up. Check the tightness of the chain and lubricate the chain in routine maintenance inspections.



Make sure that only qualified personnel perform inspection, troubleshooting and part replacement.



Disconnect all power, including external control power that may be present before serving the frequency drive controllers.

OPERATING ISSUES	CAUSES	RECOMMENDATIONS
The machine is not powering on	Main power is turned off	Check the power going into the machine. Verify that switch is turned on.
	Wrong parameter setting	Reset parameter
	PLC Failure	Replace PLC
	No display on PLC screen	
	Breaker Failure	Replace Breaker
Turntable does not run	Pallet overweight	Reduce the pallet weight
	Chain falls off	Check the chain transmission mechanism (loosen the chassis screws, remove the turntable cover and check whether the chain and tension are abnormal.
	Loose Chain	
	Inverter failure or damage	The output protection of the inverter will flash the fault code on the inverter. Look up the corresponding fault code and troubleshoot method. Replace inverter if damaged.
Film Carriage malfunction	Limit switch failure or damage	Overhaul or replace the limit switch
	Photocell failure or damage	Overhaul or replace the photocell
	Loose chain or interference	Overhaul the vertical lifting chain system

	PLC Failure	Replace the PLC	
	Carriage Up/Down button is unresponsive		
	Inverter failure or damage		Troubleshoot and replace inverter if damaged
	Motor Failure		Overhaul the lifting motor
	The bottom safety plate is stuck		Overhaul if the safety plate is stuck or the safety switch is damaged
Film clamping failure	Air supply is not enough or disconnected	Overhaul if the air tube is leaking and make sure the air supply is 0.6MPa	
	Clamp rubber falls off or damage	Fasten or replace rubber	
	Magnetic valve or cylinder failure	Replace magnetic valve or cylinder	
Film Breaks	Clamping is not tight enough	Refer to previous troubleshoot	
	The position of Roll making roller falls off the position	Adjust and fasten the roller	
	Film is too thin or insufficient quality	Replace film roll (Thickness $\geq 20\mu\text{m}$)	
Film clamp does not open	Clamping sensor does not detect signal	Overhaul the sensor cable or replace clamping sensor	
Turntable does not stop	Home position sensor does not detect signal	Overhaul the sensor cable or replace home position sensor	

6.Components & Parts

Turntable

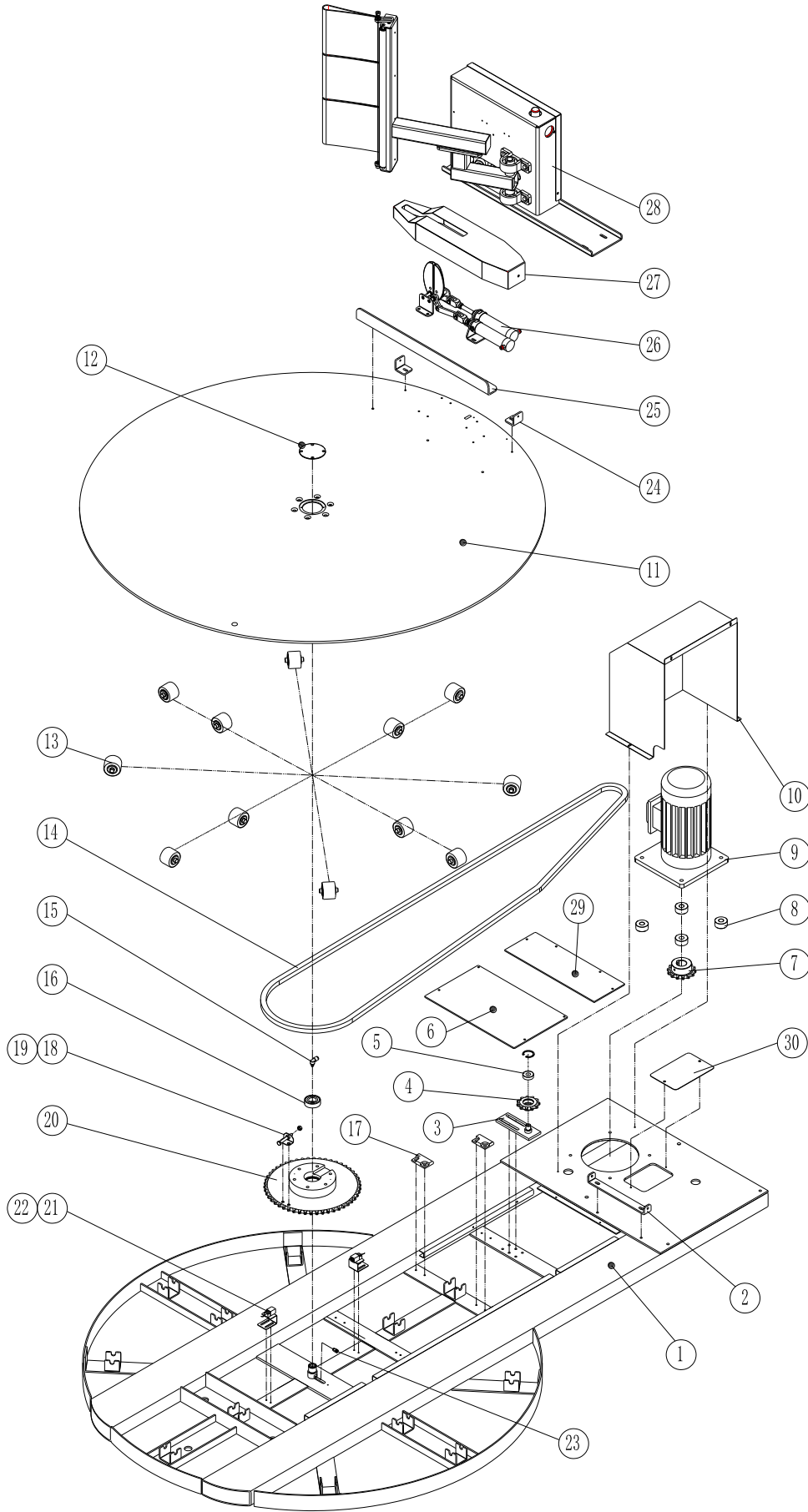

Figure 16

Turntable			
No	Part No	Description	QTY
1	XT4505-DM-0100	Turntable Base	1
2	XT45N-0101-1-V1	Hinge fixing base	1
3	10000000697	Tension pulley bracket	1
4	XT4505-0129-V1	Tension pulley:12B-Z11	1
5	XT8020-0614	Plastic Spacer15*5	1
6	XT4505-DM-0126	Protection Cover	1
7	10000000486G	Motor chain pulley: 12B, 14 teeth	1
8	XT8020-0506	Plain roller	4
9	30 CV-32-750-30	Vertical Gear motor 0.75KW	1
10	XT4505-DM-0102	Motor cover	1
11	10000000510-DM-HJ	Disc	1
12	XT4505-DM01-09	Round Cover	1
13	10010000617	Turntable roller	12
14	GB/T1243	Chain 12B-190 keys with joint	1
15	KSL06-M6	L type rotating joint ϕ 6-M6	1
16	GB/T276	Bearing 6205-2RS	1
17	10000000548	Chain noise reducer	3
18	10000000688	Contacting plate holder	2
19	GB/T5783-2000	Hex bolt M8*60	2
20	10000000693-DM	Center turntable pulley:12B-Z50	1
21	PL-05N NPN Type	Approximate Switch	2
22	XT45N-0110	Switch holder	2
23	FPC6-M5	Welding plate	1
24	XT4505-DM01-02	Bracket	2
25	XT4505-DM01-01	Positioning stopper plate	1
26	XT4505-DM01.01	Clamping unit	1
27	XT4505-DM01-08	Clamping cover	1
28	XT4505-DM01.02	Film cutting unit	1
29	XT4505-DM-0126-1	Protection cover A	1
30	XT4505-0138-CN82	Motor bottom cover	1

Film Attach Unit

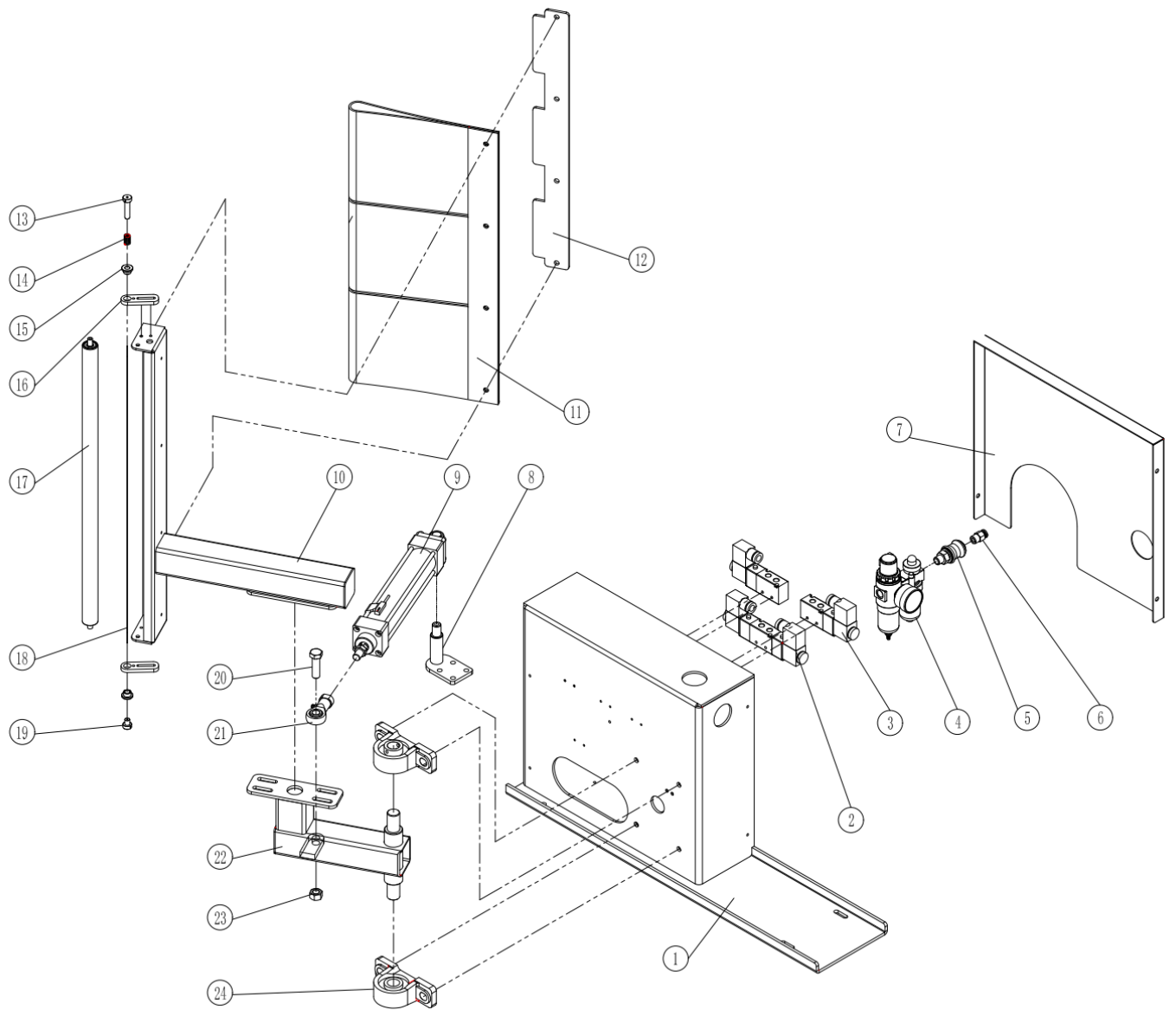

Figure 17

Film Cutting Unit

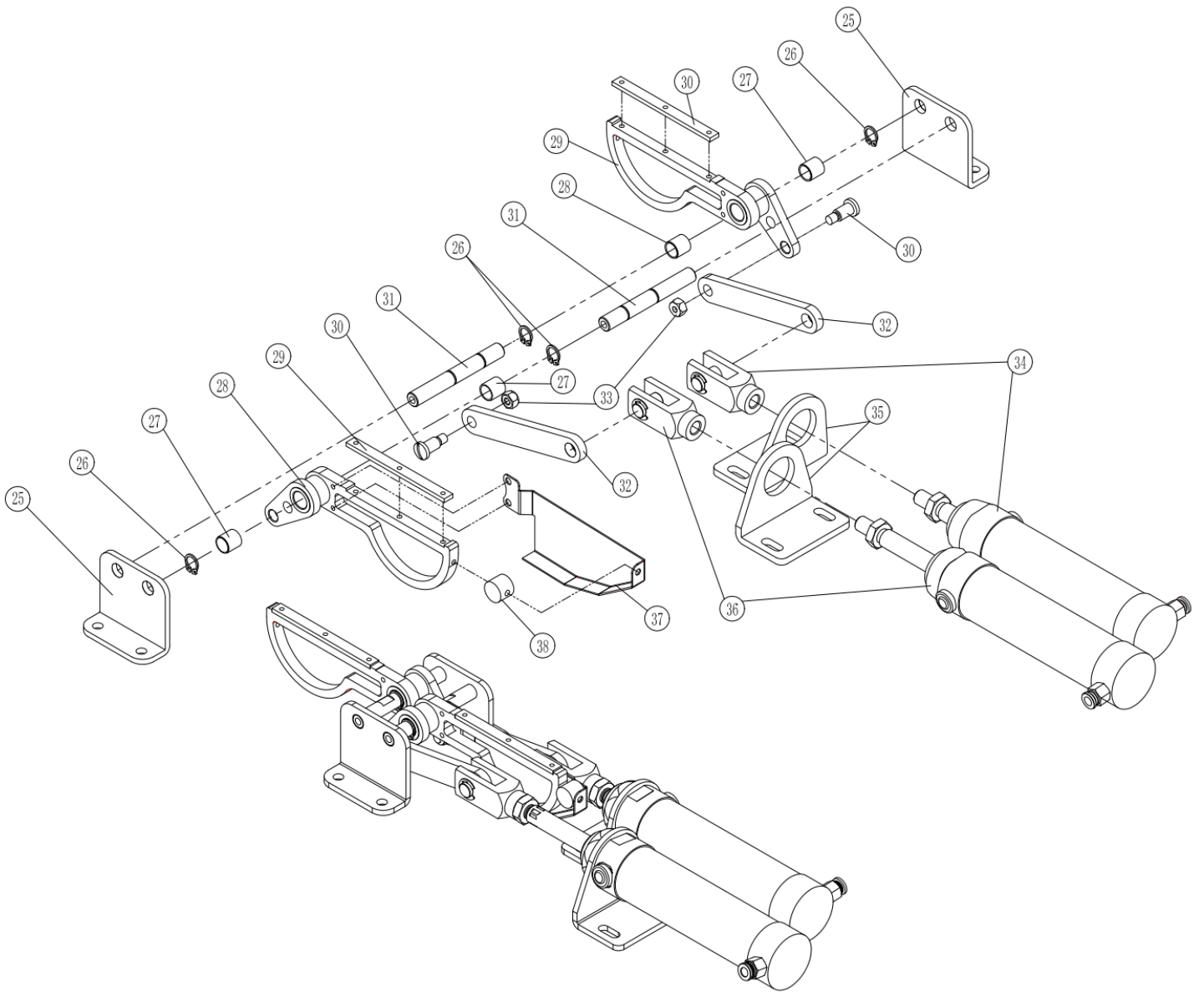

Figure 18

Film Attaching & Cutting Unit			
No	Part No	Description	QTY
1	XT4505-DM02-01	Film cutting holder	1
2	BM530-02-D9	Magnetic valve	1
3	PU322-02-S9	Magnetic valve	1
4	AFC20001	Pneumatic combination parts	1
5	HSV08	Manual valve	1
6	FPC 8-02	Screw	1
7	XT4505-DM02-05	Film breaker base cover	1
8	XT4505-DM02-13	Cylinder holder	1
9	SC40*175SCA	Cylinder 40*175	1
10	XT4505-DM02-03	Roller holder	1
11	W550*T2mm-L520mm	Wiping PVC belt	1
12	XT4505-DM02-04	Wiping belt cover	1
13	XT4505-DM02-08	Heating element copper joint A	1
14	XT4505-DM02-09	Heating element tension spring	2
15	XT4505-DM02-12	Bakelite sleeve	2
16	XT4505-DM02-07	Heating element base	2
17	20600000153-V1	Tension roller	1
18	Φ1*700	Heating element	1
19	XT4505-DM02-11	Copper joint B	1
20	M12*45	Hex Bolt M12*45	1
21	SC-40-U	Fish eye joint PHS12	1
22	XT4505-DM02-02	Rotating arm welding parts	1
23	M12	Hex Bolt M12	1
24	UCP204	Bearing	2
25	XT4505-DM01-05	Clamping arm base	2
26	10	Shaft Ring	4
27	M6*12-N	Screw	2
28	MB1012	Oil free bearing	4
29	XT4505-DM01-02	Clamping arm unit A	1
30	XT4505-DM02-1	Clamping rubber	2
31	XT4505-DM01-04	Clamping arm rotating arm shaft	2
32	XT4505-DM01-03	Clamping arm unit B	1
33	XT4505-DM01-07	Connection pole	2
34	APDCL-32-B50-Y	Cylinder	1
35	XT4505-DM01-06	Cylinder Base	2
36	APCCL-32-B50-Y	Cylinder	1
37	M6	Hex fasten bolt	2

Film Carriage

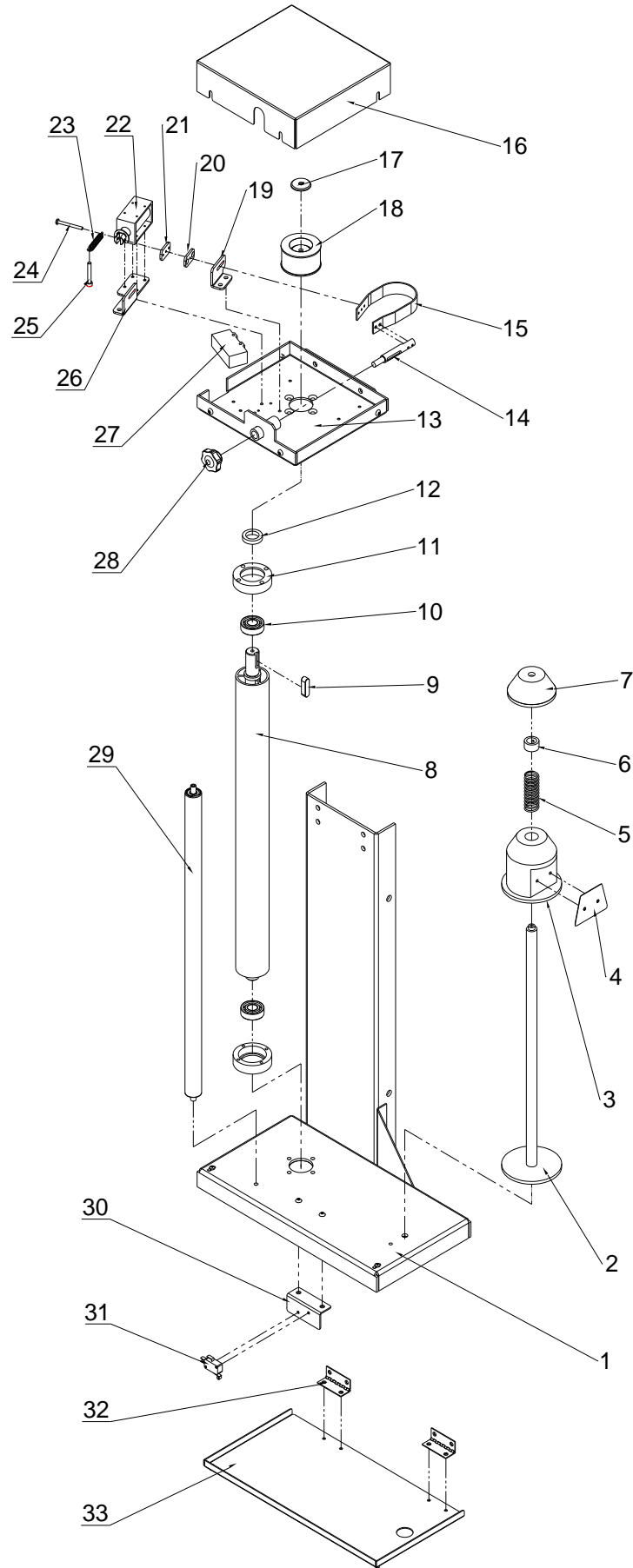

Figure 19

Film Carriage			
No	Part No	Description	QTY
1	XT45Z-02-V2	Bottom fixed plate assembly	1
2	XT45M-19	Film roll: Welding assembly	1
3	10000000033	Film roll: bottom seat	1
4	10000000035-V1	Spring Plate	1
5	10000000030	Spring	1
6	20545000404-V1	Lock Ring	1
7	10000000034	Film roll: Top seat	1
8	XT45Z-06-V1	Rubber roller unit	1
9	GB/T1096	Plain key 6*6*25	1
10	GB/T276	Deep groove bearing	2
11	XT45M-12-V3	Rubber roller bearing seat	2
12	XT4508A-0205	Lock Sleeve	1
13	XT45Z-01-V2	Film carriage top plate	1
14	XT45Z-11-V1	Brake shaft	1
15	XT45Z-11-1	Rubber belt L218*W12*T2mm	1
16	XT45Z-03-V1	Top film carriage cover	1
17	XT45Z-09	Shaft lock ring	1
18	10000000046	Tension friction wheel	1
19	XT4505-DM03-01	Guiding plate, A	1
20	XT4505-DM03-04	Belt bracket B	1
21	XT4505-DM03-03	Belt bracket A	1
22	ZYE1-1564Z	Electromagnet	1
23	TD98-03-39	Spring	1
24	M4*40	Cross head screw	1
25	M5*35	Hexagon socket cap head screw	1
26	XT4505-DM03-03	Guiding plate B	1
27	FR-2MX	Photocell	1
28	M8*20	Star knob	1
29	XT45M-14	Guide roller	2
30	XT45Z-16	Switch install plate	1
31	KW3-0Z-2	Micro switch with Wheel	1
32	QB/T3876	Hinge:50*38	2
33	XT45Z-15-V3	Safety plate	1

Tower and Lift

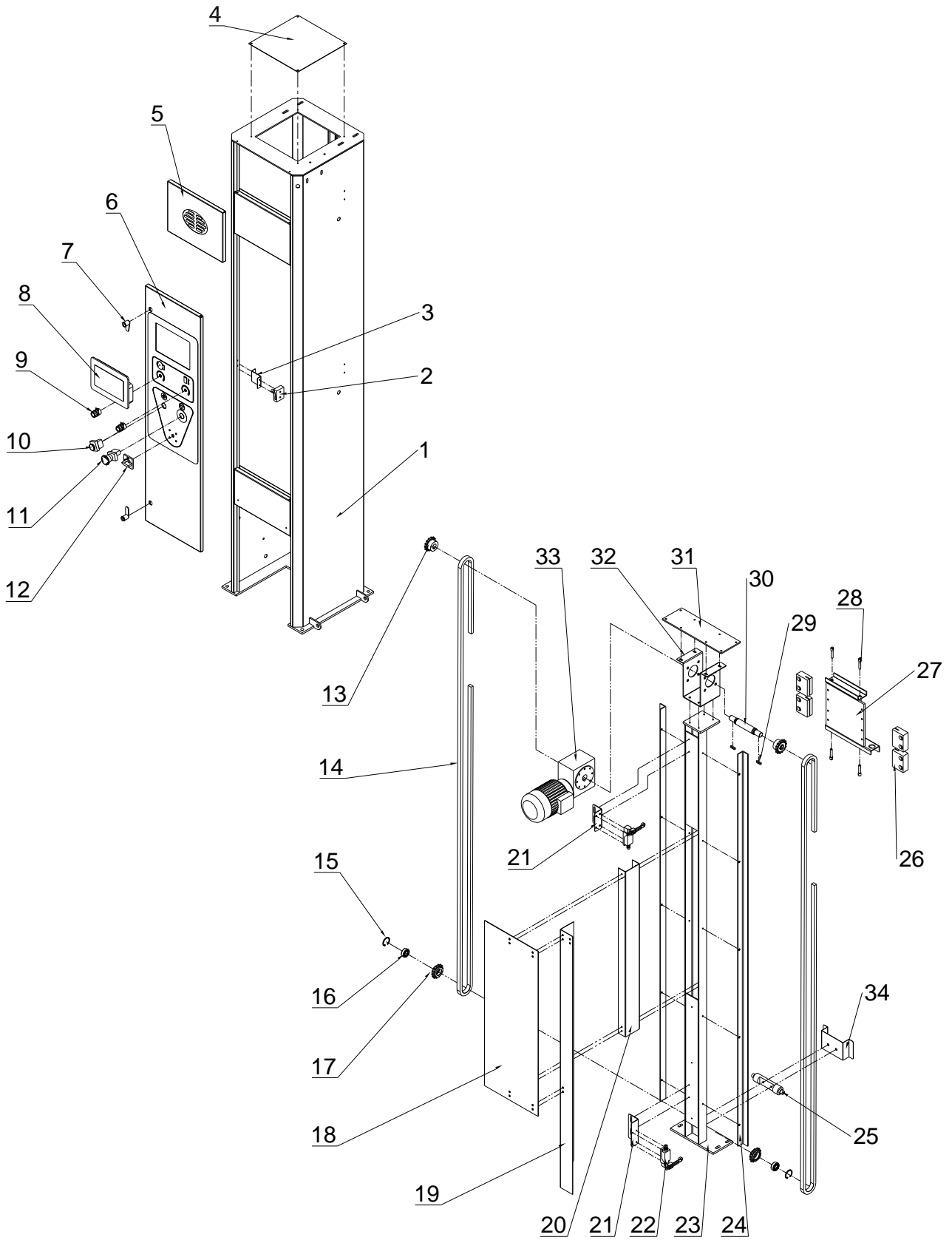

Figure 20

Tower and lift Assembly			
No	Part No	Description	QTY
1	XT4505-0201-V2	Tower body	1
2	Z15G 1703 15A	Door safety switch	1
3	XT4505-0206	Z type holder	1
4	XT4505-0204	Tower body top cover	1
5	XT4505-0203	Tower body top protection plate	1
6	XT4515-02-002	Door	1
7		Latch	2
8	DOP-107BV	Delta Touch Screen	1
9	NRV228P-B472-4.7K + MF-A03	Potentiometer + Knob	2
10	HBDS1-AWY-11	Start Button	1
11	K22-81R	Emergency stop switch	1
12	ULW26GS-20/04-1	Power switch	1
13	10000000549	Lifting motor chain wheel:08B 14 teeth	2
14	08B P12.7	Chain 08B(P12.7),314 joints	2
15	GB/T893.1 D35	Locking ring 35	2
16	GB/T276	Bearing:6202-ZZ	2
17	XT4505S-0113	Chain wheel:08B 14 teeth	2
18	XT4505S-0110-V2	Electrical housing	1
19	XT4505S-0115-V2	L Channel bracket	1
20	XT4505S-0105	Electrical component storage	1
21	XT4505-0119-CN82	Bottom limit switch seat	2
22	XCM2145L1	Limit switch	2
23	XT4505S-010702-V4	Inner tower assembly	1
24	XT4505S-0104	Guide rail	2
25	XT4505S-0103G	Sliding block	4
26	XT4505S-0102-V1	Driven shaft	1
27	XT4505S-0109-V1	Connection board assembly	1
28	XT4505S-0111	Screw	4
29	GB/T1095	Key 6*6*25	2
30	XT4505S-0101	Driving shaft	1
31	XT4505S-0108	Top lifting board	1
32	XT4505S-010701	Motor Seat	1
33	NMRV050-60-T712-4 B414	Lifting reduction motor	1
34	XT4505S-01-20	Lifting Pulley Cover	1

Electrical Components

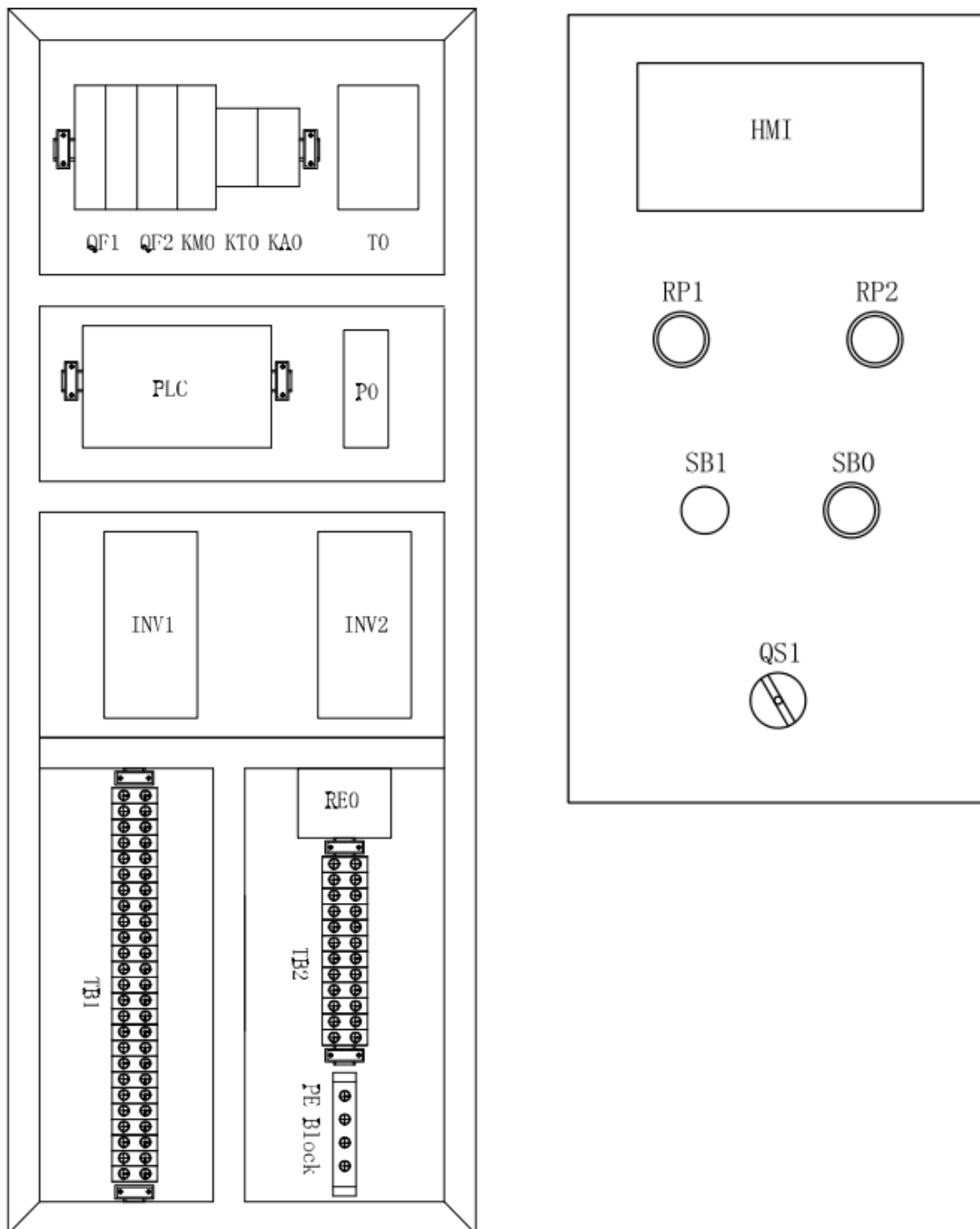

Figure 21

No	Part No	Description	QTY
QF1	Circuit Breaker	NB1-63 2P C16A6KA (R)	1
QF2	Circuit Breaker	NB1-63 1P C2A6KA (R)	1
KMO	Contacto	LC1D18BD 18A 24VDC	1
KTO	Time Relay	REXL2TMBD	1
KAO	Middle Relay	LY2N-Z24VDC	1
TO	Transformer	10001F-O 96VA	1
PLC	Delta PLC	DVP40ES200R	1
P0	Power Supply	LRS-50-24	1
INV1	Turntable inverter	GD20-0R7G-S12-UL	1
INV2	Lift inverter	GD20-0R4G-S12-UL	1
TB1	Connector	TB1-1538	1
RE0	Remote controller unit	BHT03G	1
TB2	Connector	TB1-1512	1
PE	Terminal Connector	5 ports, 3*15	1
HMI	Touch screen	DOP-107BV	1
RP1	Potentiometer	NRV228P-B472-4.7K	1
RP2	Potentiometer	NRV228P-B472-4.7K	1
SB1	Start Button	HBDS1-AWY-11	1
SB0	Emergency button	K22-81R	1
QS1	Power isolation switch	ULW26GS-20/04-1	1

Electrical Diagram

