



---

Direct Heat Foot Sealers

Models: W-220DT(S), W-300DT(S), W-450DT(S)

**Distributed By:**

Copyright © 2014 by Stephanie Hwang

All rights reserved. No part of this publication may be reproduced, distributed, or transmitted in any form or by any means, including photocopying, recording, or other electronic or mechanical methods, without the prior written permission of the publisher, except in the case of brief quotations embodied in critical reviews and certain other noncommercial uses permitted by copyright law. For permission requests, write to the publisher, addressed "Attention: Permissions Coordinator," at the address below.

Sealer Sales, Inc.  
8820 Baird Avenue  
Northridge, Ca 91324  
[www.sealersales.com](http://www.sealersales.com)

Printed in the United States of America

# General Information

---

Thank you for purchasing our W-Series Direct Heat Foot Sealers.

This owner's manual contains information relating to your sealer. The manual will provide you with basic information concerning both operation and maintenance of your new machine. Please read it carefully as failure to do so may result in bodily injury and/or damage to the equipment.

Please fill in the information below. You will find the information on the machine identification plate. You will need this information when ordering replacement parts or making technical inquiries.

No part of this manual may be duplicated, reproduced, stored in a retrieval system, translated, transcribed, or transmitted in any form without the express prior written permission of Sealer Sales.

---

## WHDT EQUIPMENT INFORMATION

---

❖ Model #

---

❖ Serial #

---

❖ Purchase Date:

---

❖ Reference # (found on packing slip)

---

❖ Owner:

---

# Safety Instructions

---



**WARNING!** *Below are general safety precautions and warnings that should be understood prior to setting up or operating your equipment. Read and fully understand all instructions and warnings prior to using this unit. Your safety is most important! Failure to comply with procedures may result in serious injury or property damage. Remember: Your personal safety is your responsibility.*

Unsafe practices or unauthorized modifications could result in accidents or property damage. Failure to follow these safety rules and take necessary precautions can result in serious injury as well as damage to equipment.

- ❖ Never operate or service your sealer until you have read this manual completely and understand it fully.
- ❖ Plug the sealer into a standard 120 Volt, 60Hz wall outlet or surge protector.
- ❖ Do not use the sealer if the power cord, plug or any other parts are damaged. Be sure not to allow the power cord to drape into your work area. Check that all parts are operating properly and perform the intended functions. Check for any worn parts before starting operation. Check for all other conditions that may affect the operation.
- ❖ Reduce risk of unintentional starting. Make sure the power switch is in the "OFF" position before connecting to the power source.
- ❖ Always disconnect sealer from power source before servicing, changing accessories or cleaning the unit.
- ❖ To provide protection against the risk of electrical shock, the power connection must be properly grounded at all times.
- ❖ Do not leave the sealer unattended when in use. Disconnect the sealer from the power source before leaving the work area.
- ❖ Sealer is used solely for sealing thermoplastic materials. Using the machine for any other purpose can cause damage to the machine and operator.
- ❖ While operating machinery, wear close-fitting clothing and tie back long hair to prevent any external items from getting caught in the machine. Do not wear jewelry when operating the sealer.



- ❖ Never touch the sealing bars with your bare hands while the sealer is plugged into a power source, in operation or just finished operation. Touching heated areas may cause fire and/or severe burns.
- ❖ While machine is in operation, do not place fingers, tools, or other foreign objects on or into the machine. Do not place hands or fingers near pinch points. Do not touch machine while it is in operation. Perform all procedures carefully and watch where hands and fingers are at all times.
- ❖ The sealer is not water resistant or water proof. Spraying down the machine will damage machine or cause electrical shock. Do not submerge the sealer into water or liquid.
- ❖ Do not operate sealer in a corrosive or humid environment.
- ❖ Always keep the machine clean, lubricated and in good working condition. Follow any maintenance and lubrication procedures outlined in this manual. Make sure unit is disconnected from power source before cleaning.
- ❖ NEVER use any accessories or parts from other manufacturers. Machine should not be altered or modified using parts that are not genuine authorized parts. Doing so will VOID YOUR WARRANTY.
- ❖ Never leave the sealer unattended. Be safe, disconnect the sealer from power source before leaving work area.
- ❖ Always keep out of reach of children and pets.
- ❖ Close supervision is necessary when any appliance is near persons with reduced physical, sensory or mental capabilities or lack of experience and knowledge . This sealer is NOT to be used by children or by persons with reduced physical, sensory or mental capabilities or lack of experience and knowledge.
- ❖ DO NOT use the sealer outdoors.
- ❖ DO NOT use the sealer while under the influence of drugs, medications or alcohol.

**SAVE THESE INSTRUCTIONS - REFER TO THEM OFTEN AND USE THEM TO INSTRUCT OTHERS.**

# Introduction

---

W-Series Direct Heat Foot Sealers are designed for sealing many different types of thermoplastic materials including: coated aluminum foil, Kraft paper, cellophane, polypropylene, poly-nylon, and other thicker materials up to 20mil in total thickness. Please note that our direct heat sealers would not be appropriate for sealing polyethylene and/or polyvinyl chloride.

## Features of the W-Series Direct Heat Foot Sealers

*Your Direct Heat foot sealer is equipped with a wide range of standard features and capabilities.*

- ❖ Direct heat sealing / constant heat sealing system
- ❖ Heavy duty all metal construction
- ❖ 26" pedestal stand with optional 36" stand available
- ❖ Simple to use - minimal operator training
- ❖ German manufactured temperature controller that maintains the seal bars at a proper temperature providing consistent seal quality
- ❖ Electronic timer (0-6 seconds) to adjust sealing time providing for consistent seal quality
- ❖ Equipped with protector bars around the sealing bars to prevent injury
- ❖ Hands free sealing activated by footswitch
- ❖ Sealing width: 1/2" (15mm)
- ❖ Adjustable work table
- ❖ Options: meshed (T-version) or serrated (TS-version) sealing bars

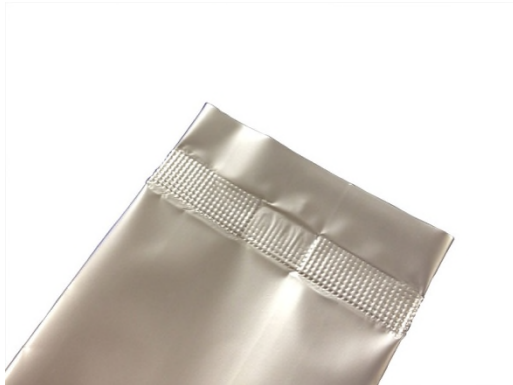

**Figure 1.** Meshed seal line



**Figure 2.** Serrated seal line

## How Do W-Series Direct Heat Foot Work?

### Basic

### Principles

Place material on lower sealing bar. Press foot board to bring upper seal bar down.

Our W-Series direct heat foot sealers maintain constant heat in both sealing jaws. Direct heat sealers consume power as long as the sealers remain on thus providing better heat penetration than impulse sealers. The temperature and length of the seal time will depend on the characteristics of the bag being sealed. The sealing process is simple: The operator places material on lower sealing bar of sealer and presses the foot board to bring the upper sealing bar down. Operator will release foot board when sealing is complete.

## Specifications

	W-220DT/S	W-300DT/S	W-450DT/S
Power	110V/60Hz	110V/60Hz	110V/60Hz
Watts	250W	350W	400W
Seal Width	15mm	15mm	15mm
Sealing Length	8"	12"	18"
Seal Type	Meshed (I) / Serrated (IS)	Meshed (I) / Serrated (IS)	Meshed (I) / Serrated (IS)
Temperature Range	0°C-300°C	0°C-300°C	0°C-300°C
Dimensions	13" x 13" x 35"	13" x 13" x 35"	19" x 13" x 35"
Shipping Dimensions	TBD	31" x 18" x 13"	TBD
Net Weight	28lbs	33lbs	35lbs
Gross Weight	TBD	41lbs	TBD

# Getting to Know your Direct Heat Foot Sealer

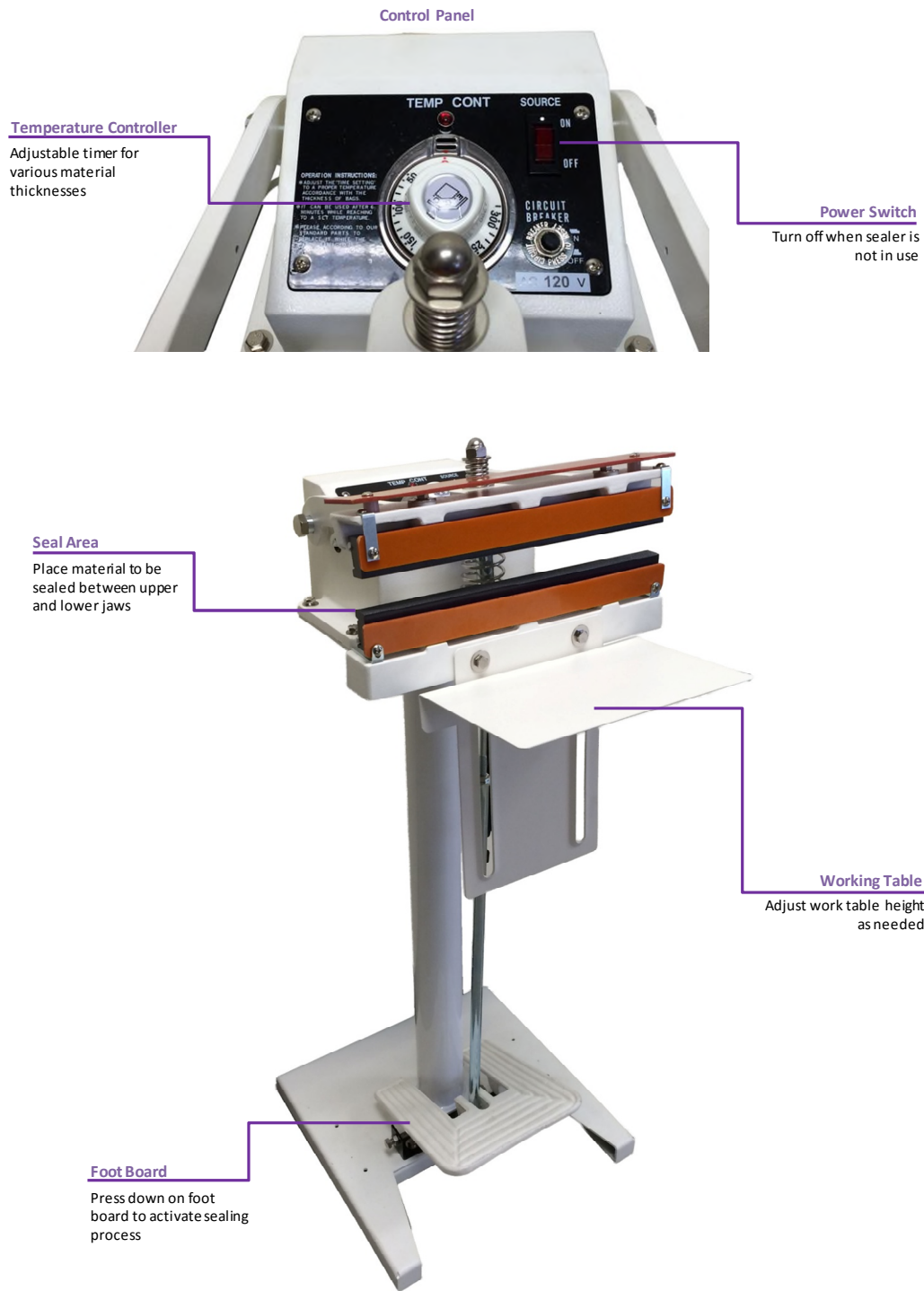

Figure 3. W-Series Direct Heat Foot Sealer Overview



# Electrical Circuit Diagram

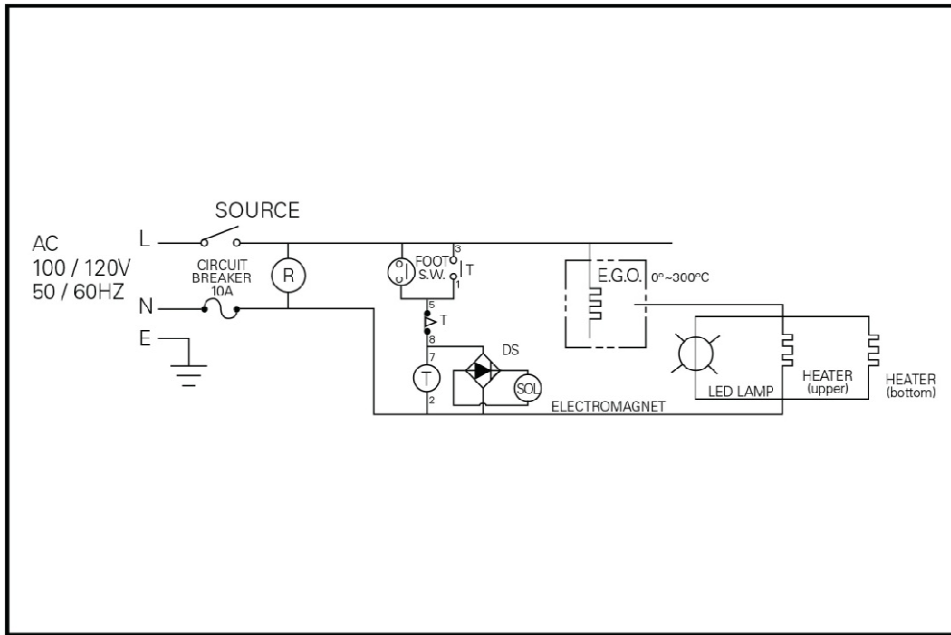

Figure 4. Electrical Circuit Diagram for W-Series Direct Heat Sealers

# Operating your Sealer

---

## Assembly Instructions

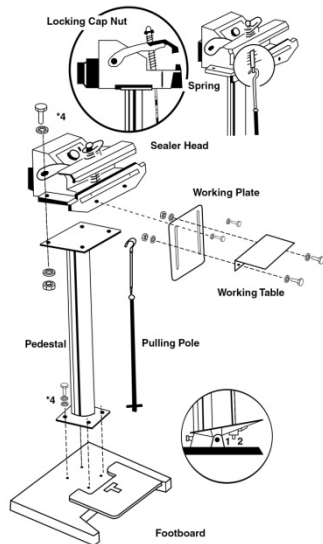

Figure 5. Double Foot Assembly Diagram

1. Position the pedestal on the floor standing upright.
2. Mount the complete sealer head to the top of the pedestal and attach with four screws.
3. Bring the upper jaw down and position the small pulling pole/plate set (**Figure 12, Item #9B**) through the pressing spring (**Figure 12, Item #9A**).
4. Gently push the upper jaw to meet the lower jaw. While jaws are compressed, reach under the unit and hook the pulling pole (**Figure 12, Item #5**) onto the small pulling pole/plate set.
5. With jaws still compressed, lift up the foot pedal to a 45° angle and slide the metal foot pedal rod onto one of the two pre-molded slots. This will create tension on the foot pedal and cause the pedal to stand upright at 45°.
6. Sealer is now ready to operate.
7. To install the optional working plate and table, remove the screws from bottom sealing jaw and install the working plate and table.

## Operation



1. Before operating, check for any worn parts of the sealer. Make sure the sealing bars are clean and without residue.
2. Insert the power cord into the correct receptacle (110V).
3. Turn the power switch on.
4. Set the sealing temperature on the temperature controller depending on the material to be sealed. (Note: Temperature on the dial is Celsius, not Fahrenheit.) Always start with a lower temperature setting and gradually increase the temperature as needed. Allow 5-10 minutes for the sealer to reach the set temperature. The light above the temperature controller will turn off when the unit has reached the set temperature.
5. Place material to be sealed on the lower sealing jaw and press the footboard to bring the upper sealing jaw down. Release the footboard when sealing process is complete.
6. When sealer is not in use, turn off the power switch.



**Please note: Sealing bars will be extremely hot. Do not touch the sealing bars as this could cause severe burns.**

## Tips for Successful Sealing

1. If the seal is broken or damaged, decrease the sealing time / temperature.
2. If the seal is not fully welded, increase the sealing time / temperature.
3. If the sealing material sticks to the sealing bars, decrease the sealing time / temperature.
4. Always keep the sealer clean. Remove any residue found on the sealing bars. Silicone spray may be used.



5. Be sure to turn off the power or unplug the unit before replacing any parts.

# Maintenance

---

The following maintenance procedures should be followed to ensure the longevity of your W-Series Direct Heat Foot Sealer.

## Inspection and Cleaning

1. Inspect your machine daily.
2. Make sure the unit is not left on when not in use. Never leave unit on overnight. This will shorten the life of the parts.
3. Find the lowest temperature that will still seal the bag.
4. Use a clean cloth to remove any plastic residue remaining on the sealing bars. We recommend using silicone spray to clean. Spray the silicone spray onto a shop cloth or toothbrush. Wipe down the sealer when the sealer is turned off and cool to touch. Never spray the silicone spray directly on the unit.

## Replacement Parts



Before changing any parts, turn off and unplug sealer.

Please make sure parts purchased are from an authorized distributor of W-Series sealing equipment.

## Replacing Heater (s)

Our W-Series Direct Heat Foot Sealers will require new heaters from time to time. There are two heaters found on the unit, one in the upper sealing jaw and one in the lower sealing jaw.

Remove the old heater on either the top and/or bottom sealing jaw. Unscrew the heater loose from the sealing jaw and base of sealer. Remove the thermostat plate to access the other end of the heater. We suggest marking down the exact locations of the connections in order to accurately replace the new heater. Note: In order to the fully remove and install the heater one may also need to separate the head of the sealer from the base.



Figure 6. Loosen screws found on sealing jaw.

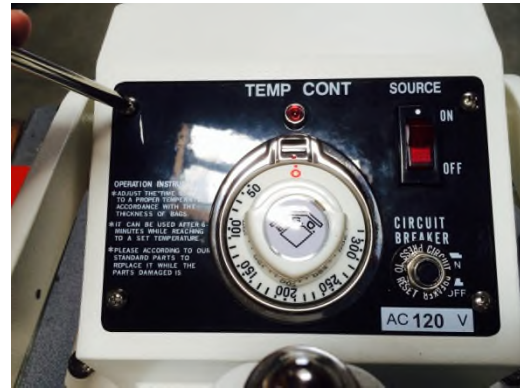

Figure 7. Remove thermostat plate.

To install new heater, remove the old heater and crimp on the new heater. Following your marked connections, install the new heater back on the sealing bar and screw to tighten back into place.

## Replacing Thermostat

1. To remove the thermostat, remove the thermostat cap and four screws from the thermostat control plate. Then, remove the two screws attaching the thermostat plate to the control panel.



Figure 8. Remove thermostat cap.



Figure 9. Remove two screws attaching thermostat plate to the control panel.

2. Unplug the two connections from the thermostat base.

3. Unscrew the heaters from the bottom sealing jaw in order to remove the thermostat sensor from the sealing jaw. Note: In order to fully remove and install the thermostat, one may also need to separate the head of the sealer from the base.



**Figure 10.** Unplug two connections from thermostat base found inside sealer head

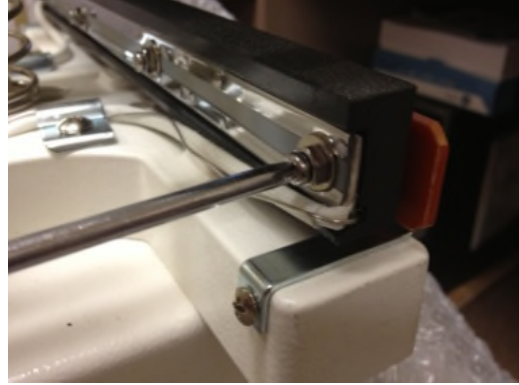

**Figure 11.** Unscrew heaters from bottom sealing jaw

# Parts Diagram

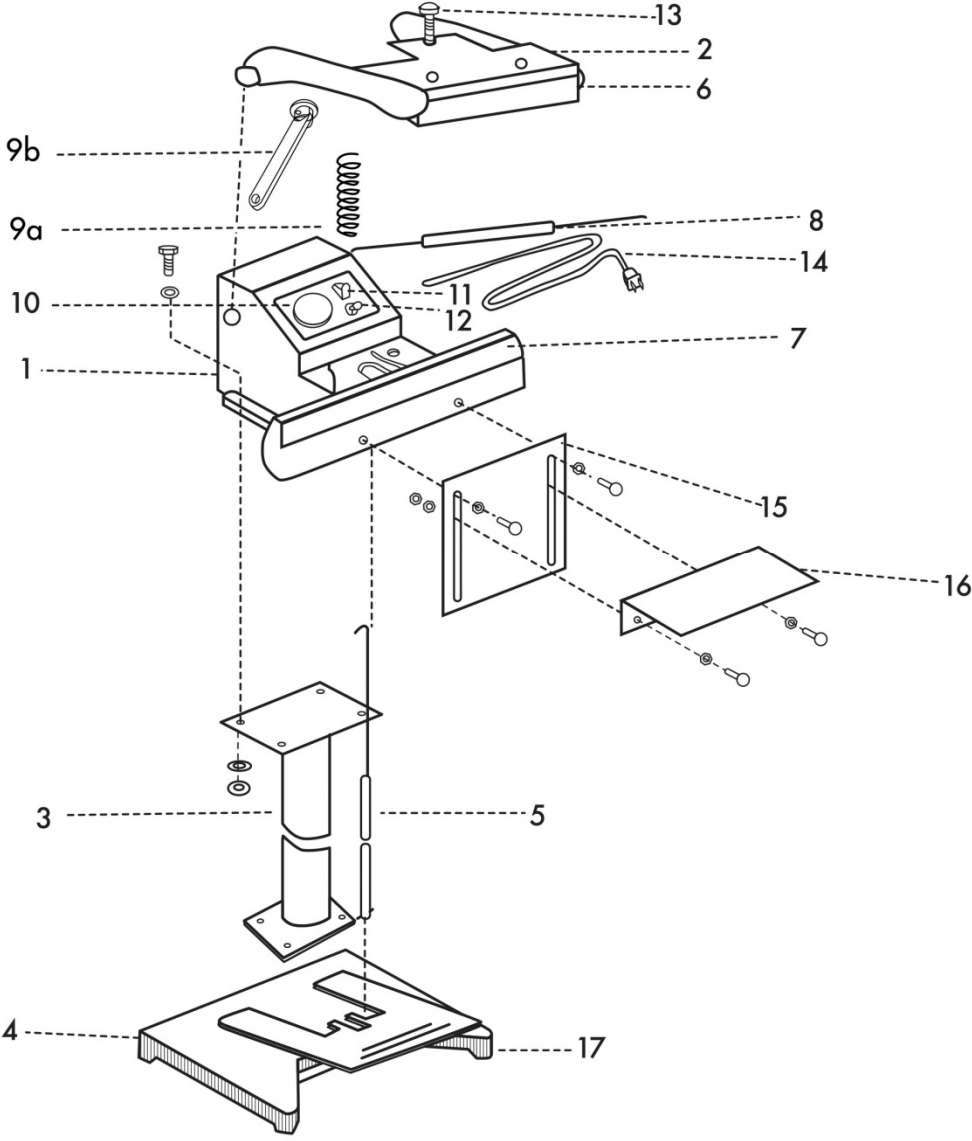

Figure 12. Spare Parts Diagram Overview

Item	Part #	Description	Comments
1	<b>WHDH-1</b>	Control Set Bracket	
2	<b>WHDH-2</b>	Upper Bracket/Jaw (same as W-300T, but with holes)	
	<b>WHDH-1/2</b>	Control Set Bracket (#1) and Upper Jaw (#2) and accompanying screws	
3	<b>ST-WH</b>	Standing Tube	
3a	<b>STE-WH</b>	Standing Tube Extended, 36"	
4	<b>WHDF-4</b>	Pedal Base	
	<b>FB-WH</b>	Foot Board	
5	<b>PPS-WH</b>	Level Set, Pulling Pole Set	
5a	<b>PPSE-WH</b>	Level Set, 36"	
	<b>ST+PP-WH</b>	Standing Tube + Pulling Pole Set	
	<b>STE+PPE-WH</b>	Standing Tube, Extended, 36" + Pulling Pole Set	
6A		PTFE Coated Sealing Bar - W-220DT - Pair (upper and lower)	
6C	<b>WHDH-3A</b>	PTFE Coated Sealing Bar, Pair, Meshed - W-300DT	
	<b>WHDH-3B</b>	PTFE Coated Sealing Bar, Pair Coated, Serrated (line) - W-300DTS	<b>sold as pair only - WHDH-3A / 3B</b>
6D		PTFE Coated Sealing Bar - W-450DT - Pair (upper and lower)	
7A		PTFE Coated Sealing Bar - W-220DT - Pair (upper and lower)	
7C	<b>WHDH-3A</b>	PTFE Coated Sealing Bar, Pair, Meshed - W-300DT	<b>sold as pair only - WHDH-3A / 3B</b>
	<b>WHDH-3B</b>	PTFE Coated Sealing Bar, Pair Coated, Serrated (line) - W-300DTS	
7D		PTFE Coated Sealing Bar - W-450DT - Pair (upper and lower)	
8A		Heater Element - W-220DT	
8B	<b>WHDH-11</b>	Heater Element, 1 piece E-92302	<b>for W-300DT</b>
8D		Heater Element - W-450DT	
9A	<b>W-300T-12</b>	Pressing Spring, Large	
9B	<b>WHLF-9A</b>	Short Pulling Pole and Plate Set	
10	<b>TMC-WHDH</b>	Thermostats (E.G.O) E-010	
11	<b>WHLH-7</b>	Power Switch, 3P, 15A/125V (W-Series)	
12	<b>WHI-11a</b>	Circuit Breaker, 7A, W-350I and W-300DAT(S)	
13	<b>WHDF-6</b>	Pressing Spring, Small W-00403	
14	<b>PWC-WH</b>	Power Cord	
15	<b>WHDF-19</b>	Working Adjusting Plate - 6 1/4" x 9 1/2" (W x L)	
16	<b>WHDF-20</b>	Working Plate - 13 1/2" x 7" (W x L)	
17		Rubber Foot	
Not Shown			
18	<b>WHDH-20</b>	Protector Bar / Isolated Plate / Top of Upper Seal Bar (old #22) - 12 1/4" x 2"	
18	<b>WHDH-23</b>	Protector Bar / Isolated Plate / Upper Sealing Bar (old #22B) - 12" x 1" (holes - 1/2")	

Figure 13. Spare Parts Diagram List



# Troubleshooting

---

Problem	Possible Causes	Solution
Upper and/or lower sealing bars not heating	1. Heater(s) are worn out.	1. Replace heaters(s) on the unit.
Unit does not heat up (both jaws are not heating up)	1. Heater(s) are worn out. 2. Temperature controller is worn out.	1. Replace heaters(s) on the unit. 2. Replace temperature controller
Temperature controller will not stay at set temperature (i.e. temperature set at 150 but temperature keeps going up)	1. Temperature controller is worn out. 2. Thermocouple is worn out (rare occasion).	1. Replace temperature controller. 2. Replace thermocouple.
Sealing jaw not activating	1. No power to the unit. 2. Timer is worn out. 3. Solenoid needs replacement. 4. Footswitch needs replacement.	1. Check power source. 2. Replace timer. 3. Replace solenoid. 4. Replace footswitch.