



---

# CN-4520A Heat Shrink Tunnel Instruction Manual

**Distributed By:**

Version 1.3  
Last Updated: 5/6/19



# General Information

---

Thank you for purchasing our CN-4520A shrink tunnel.

This owner's manual contains information relating to your machine. The manual will provide you with basic information concerning both operation and maintenance of your new machine. Please read it carefully as failure to do so may result in bodily injury and/or damage to the equipment.

Please fill in the information below. You will need this information when ordering replacement parts or making technical inquiries.

No part of this manual may be duplicated, reproduced, stored in a retrieval system, translated, transcribed, or transmitted in any form without the express prior written permission of Sealer Sales.

---

## CN-4520A EQUIPMENT INFORMATION

---

❖ Model #

---

❖ Serial #

---

❖ Purchase Date:

---

❖ Reference # (found on packing slip)

---

❖ Owner:

---

## **Important - Please read**

---

The development of a good safety program, that is rigidly enforced, is absolutely imperative when involved in the operation of industrial equipment. Our machinery is well designed and includes extremely important safety features. The part you the user play through proper installation and maintenance procedures is of far greater significance than our designs. Only properly trained individuals following rigidly enforced safety rules, as recommended by A.N.S.I. and O.S.H.A., should be allowed to operate these machines.

# Unpacking

---

## Thoroughly Inspect Equipment Upon Arrival

If goods are received short or in a damaged condition, it is important that you notify the carrier's driver before he leaves your company and insist on a notation of the loss or damage across the face of the freight bill. Unless this is done, no claim can be enforced against the transportation company.

If concealed loss or damage is discovered, notify the carrier at once and insist on an inspection. This is absolutely necessary! A concealed damage report must be made no later than ten (10) days from the date the shipment was delivered. Unless you do this, the carrier will not consider any claim for loss or damage. The carrier's agent will then make an inspection and grant a concealed damage notation. If you give the transportation company a clear receipt for the goods that have been damaged or lost in transit, you do so at your own risk and expense.

All claims must be filed within six days of delivery date or carrier will not accept them.

Sealer Sales, Inc. is willing to assist in every possible manner to collect claims for loss or damage; however, this does not hold Sealer Sales, Inc. responsible for collection on claims or replacement of material.

Do not throw away damaged pallets or box until freight inspection has occurred.

# Safety Instructions

---



**WARNING!** Below are general safety precautions and warnings that should be understood prior to setting up or operating your equipment. Read and fully understand all instructions and warnings prior to using this unit. Your safety is most important! Failure to comply with procedures may result in serious injury or property damage. Remember: **Your personal safety is your responsibility.**

Unsafe practices or unauthorized modifications could result in accidents or property damage. Failure to follow these safety rules and take necessary precautions can result in serious injury as well as damage to equipment.

- ❖ Never operate or service your shrink tunnel until you have read this manual completely and understand it fully. Make sure the machine operators and others working on the machinery are properly trained in the correct usage of the equipment and properly instructed regarding the safety procedures of operation.
- ❖ Do not tamper with the electrical wiring. Unit operates on 1 $\phi$ , 220V/240V power. Make sure the heat tunnel is installed by a qualified electrician in accordance with local electrical codes. Always disconnect the electrical power before attempting any maintenance to all electrical and/or moving parts.
- ❖ In order to prevent injury to personnel and/or machinery, do not increase settings or ratings on either electrical or mechanical overload safety devices.
- ❖ Do not use the shrink tunnel if the power cord, plug or any other parts are damaged. Do not allow the power cord to drape into your work area. Check that all parts are operating properly and perform the intended functions. Check for all other conditions that may affect the operation.
- ❖ Reduce risk of unintentional starting. Make sure all switches are in the "OFF" position before attaching to the power source.
- ❖ Always disconnect shrink tunnel from power source before servicing, changing accessories or cleaning the unit.
- ❖ To provide protection against the risk of electrical shock, the power connection must be properly grounded at all times.
- ❖ Do not leave the shrink tunnel unattended when in use. Disconnect the shrink tunnel from the power source before leaving the work area.
- ❖ Shrink tunnel is used solely for shrinking thermoplastic materials. Using the machine for any other purpose can cause damage to the machine and operator. Do NOT use the machine for any other purpose other than to shrink thermoplastic materials. Doing so may result in damage to the machine and injury to the operator.
- ❖ The use of certain types of plastic films in sealing and/or shrinking equipment may result in the release of hazardous fumes due to the degradation of the film at high temperatures. Before using any plastic film in this equipment, the manufacturer or supplier of the film should be contacted for specific information concerning the potential release of hazardous fumes. Adequate ventilation must be provided at all times.
- ❖ Before operating, please make sure no foreign objects are located in the tunnel.

- ❖ Always operate machine on a flat stable surface.
- ❖ While operating machinery, wear close-fitting clothing and tie back long hair to prevent any external items from getting caught in the machine. Do not wear jewelry when operating the shrink tunnel.



- ❖ While machine is operating do not place hands in the tunnel. Tunnel will be extremely hot and may burn your hands.



- ❖ While machine is in operation, do not place fingers, tools, or other foreign objects on or into the machine. Do not touch any moving parts while machine is operating. Fingers may get caught in between the gears and cause significant injury.
- ❖ Allow the shrink tunnel to cool to room temperature before turning conveyor off.
- ❖ Shrink tunnel is NOT washdown rated. The tunnel is not water resistant or water proof. Spraying down the machine will damage machine or cause electrical shock. Do not submerge the shrink tunnel into water or liquid.
- ❖ Do not operate shrink tunnel in a corrosive or humid environment.
- ❖ Do not operate the tunnel for extended periods of time without the conveyor running. Operating the tunnel without running the conveyor may result in damage to the conveyor.
- ❖ Always keep the machine clean, lubricated and in good working condition. Follow any maintenance and lubrication procedures outlined in this manual. Make sure unit is disconnected from power source before cleaning
- ❖ Any modifications to either the electric circuitry or the mechanical assemblies of the machinery will void any warranties associated with this equipment. Such modifications may introduce hazards that would not otherwise be associated with this machinery. Sealer Sales will not be responsible for any consequences resulting from unauthorized modifications. Doing so will VOID YOUR WARRANTY.
- ❖ Never leave the shrink tunnel unattended. Be safe, disconnect the shrink tunnel from power source before leaving work area.
- ❖ Close supervision is necessary when any appliance is near children or persons with reduced physical, sensory or mental capabilities or lack of experience and knowledge . This tunnel is NOT to be used by children or by persons with reduced physical, sensory or mental capabilities or lack of experience and knowledge.
- ❖ Good housekeeping is a good safety practice and aids in improving machine efficiency. Keep the shrink tunnel and the area around the shrink tunnel clean at all times.
- ❖ DO NOT use the shrink tunnel outdoors.
- ❖ DO NOT use the shrink tunnel while under the influence of drugs, medications or alcohol.

SAVE THESE INSTRUCTIONS - REFER TO THEM OFTEN AND USE THEM TO INSTRUCT OTHERS.



# Introduction

---

CN-4520A shrink tunnel is a conveyed, heat shrinking device that uses re-circulating electric heat in a closed chamber to shrink PVC and/or POF film around a package. Unit is equipped with an adjustable speed conveyor that allows the user to operate the tunnel up to 30 feet per minute. Two separate temperature controllers heat both the upper and lower heaters. The tunnel is heated on all four sides by ten ceramic replaceable electric heating tubes. Curtains cover the entrance and exit ends of the heat chamber to minimize the heat loss as packages travel through the tunnel.

The shrink tunnel can be used on a table top or attached to a stand as a free standing unit. The machine includes a stand and casters, allowing the operator to easily move the machine from one location to another.

## Features of the CN-4520A Shrink Tunnel

*Your shrink tunnel is equipped with a wide range of standard features and capabilities.*

- ❖ Simple to use – minimal operator training
- ❖ Equipped with electronic adjustable speed control
- ❖ Quick warm up time
- ❖ Silicone covered conveyor rollers
- ❖ Stand with casters

## Specifications

CN-4520A	
Power	220V/240V 1 $\phi$
Watts	6Kw
Amps	27Amps
Sealing Speed	0-393"/ min
Tunnel Dimensions (L x W x H)	31.5" x 17.7" x 7.9"
Max Temperature	200°C (392°F)
Max Conveyor Load	11lbs
Conveyor Size	47" x 18" x 27"
Max Film Thickness	240 Gauge
Dimensions (L x W x H)	52" x 28" x 43"
Box Dimensions (L x W x H)	55" x 30" x 30"
Weight	240-lbs

# Getting to Know your Shrink Tunnel

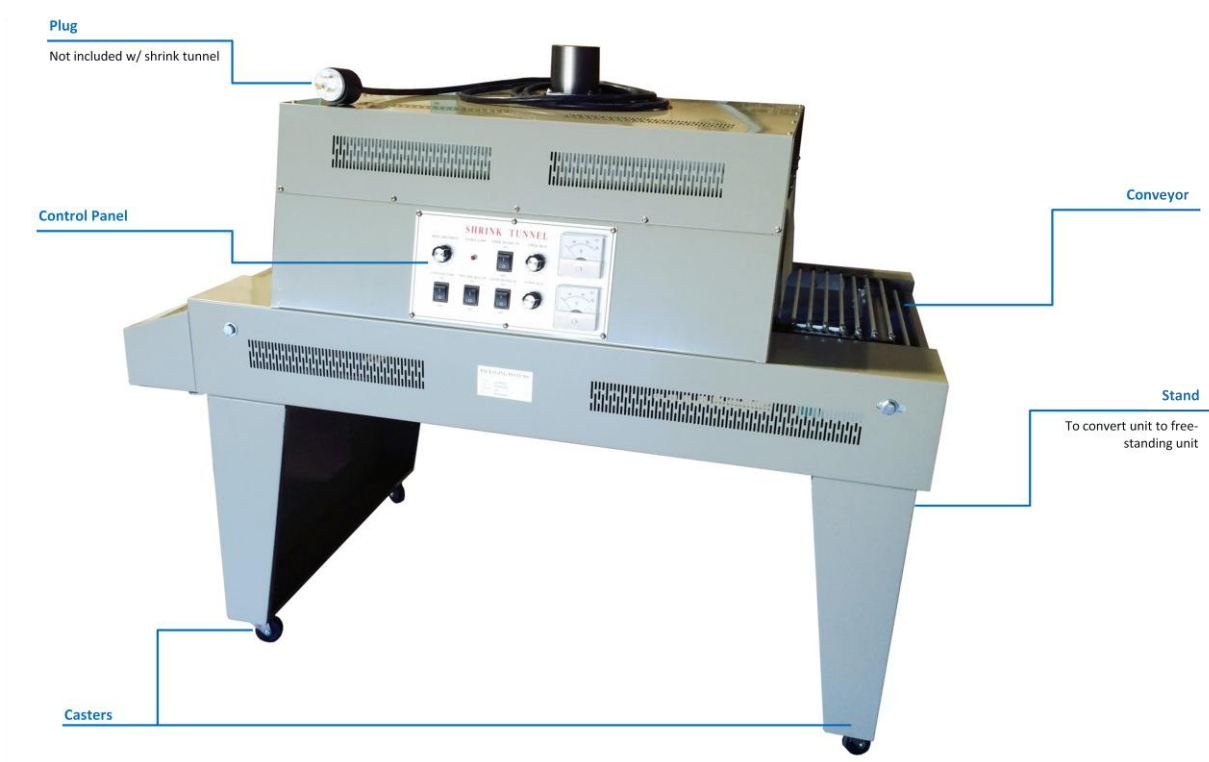

# Electrical Circuit Diagram

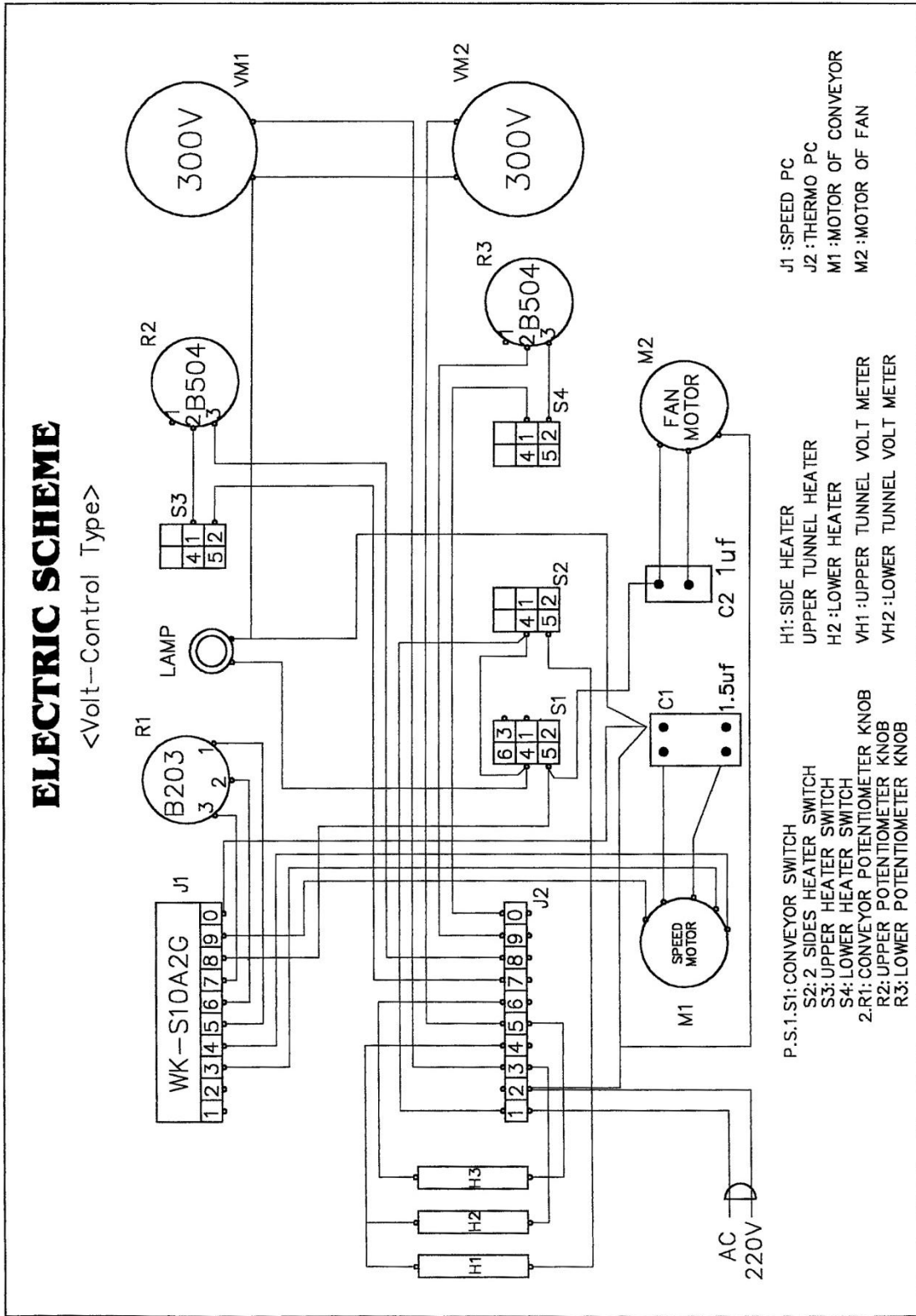

# Operating Your Shrink Tunnel

---

## Initial Set-up

Please inspect the tunnel for any obvious signs of damage, which may have occurred during shipping. If any signs of damage are detected, please contact your distributor immediately.

Place the tunnel in the desired position with the required electrical power source available. Make sure your electric wiring is adequate to guard against low voltage. If the voltage is too low, the equipment will not perform properly. ***An electrician should install a plug on the end of the main power cord. Get qualified assistance to do your installation.***

Finding the proper location is a most important function of the initial set-up. One must take several factors into consideration:

- ❖ Adequate power source
- ❖ Relationship to source of product
- ❖ Relationship to shrink tunnel
- ❖ Relationship to any conveyors necessary to transport finished product
- ❖ Convenience of operator

## Operation Set-up

1. Our shrink tunnel is equipped with an optional stand with casters. Mount the stand and casters to the machine if desired.



2. First time operation. Allow the machine to pre-heat by running at a low temperature for a few minutes. This would apply if the machine has not been in operation for a long time. The machine can sometimes be damp from storage or shipment and running at a low temperature will dry out any residual moisture.

## Operation



Figure 1. Control Panel of CN-4520A

1. Make sure the plug is well-connected in the appropriate socket to ensure safe operation. Source lamp will turn on when power is applied to the tunnel.
2. Turn on the Conveyor Start to start the conveyor. Adjust conveyor speed accordingly with the Speed Adjustment knob.
3. Turn on the Upper Heater, Lower Heater, and Two Side Heat switches. The switches will turn on the heaters of the unit located on the top of the unit, bottom of the unit and on the sides of the unit.
4. Temperature can be adjusted using the Upper Heat and Lower Heat knobs. The volt meters will display the temperature. Please note the fan on top of the unit allows the heat to circulate in the tunnel and create even temperature within the unit. Temperature can be adjusted higher or lower according to your package. Once correct settings have been maintained, temperature should not have to be adjusted again.
5. Please allow 15 minutes for the tunnel to warm up and achieve the heat settings.
6. Place package on the tunnel's conveyor belt and let the conveyor transport package into the shrink tunnel. If the shrink on the package is satisfactory, no need to make additional adjustments. If the shrink on the package is not satisfactory, make the appropriate changes and wait 5-10 minutes before testing your product again.
7. To shut down, turn down the Upper Heat and Lower Heat knobs to the lowest setting. Turn off the Upper Heat, Lower Heat and Two Side Heat switches. Allow the machine to run and cool down for approximately 10 minutes. Once machine has cooled, then turn off the conveyor. ***Following the shut down procedure will significantly prolong the life of machine.***

## Sealing Optimization

1. Getting air out of the package - the most simple and most effective way to let the air escape from the package while shrinking is to create tiny slits on the center folded end of the shrink film.
  - a. As you remove the new shrink film out of its box, determine which end of the roll is the center-folded end.
  - b. With a single edge razor blade or razor blade knife, make four hair-line cuts at every 90 degree angle starting at the cardboard core outwards.
  - c. Please also check your shrink film as some film comes pre-perfed; you would not need to create your own perforations.
2. In order to effectively shrink film packaging, your package must have a degree of rigidity to withstand the shrink force as it passes through the tunnel.
  - a. In the case of shrinking thin packages that may curl or distort during the shrink process, it is advisable to use a chipboard/cardboard backing to add strength to your package

# Maintenance

---

The following maintenance procedures should be followed to ensure the longevity of your shrink tunnel.

## Cleaning

1. Inspect your machine daily.
2. Check if there is any foreign matter or dirt adhering to the shrink tunnel
3. To clean your shrink tunnel, wipe down your tunnel with silicone spray and a shop cloth. Do not apply silicone directly to your shrink tunnel. Definitely DO NOT wash down your machine with water.
4. Check and clean the intake screens.

## Preventative Maintenance

1. Check the condition of the silicone covering the rollers. The silicone covering on the tunnel rollers should be inspected regularly to assure that no scrap pieces of film are wrapped around the rollers to cause sticking of packages. To clean, run conveyor until the affected rollers are within the heated chamber, thus heating the film residue to soften the film, then advance the conveyor to stop the rollers outside the heat chamber for cleaning. Make sure the conveyor is stopped before putting your hands or anything else in the conveyor area. If necessary to remove the film residue, use a dull, blunt- edged tool. Do not use any sharp instruments, as nicking the silicone may result in having to replace the roller covering. Repair/replace as necessary.
2. Check and clean the motor to the conveyor drive chain. Adjust the tension as needed.
3. Check for loose fasteners. Tighten as necessary.
4. Check the condition of the power cord for wear, especially if exposed to traffic.
5. Check that the tunnel is able to maintain the set temperature.
6. Check that the tunnel is able to vary the conveyor speed.
7. Check the overall wear on the roller guide rails and starter rails. Repair as needed.

# Parts Diagram

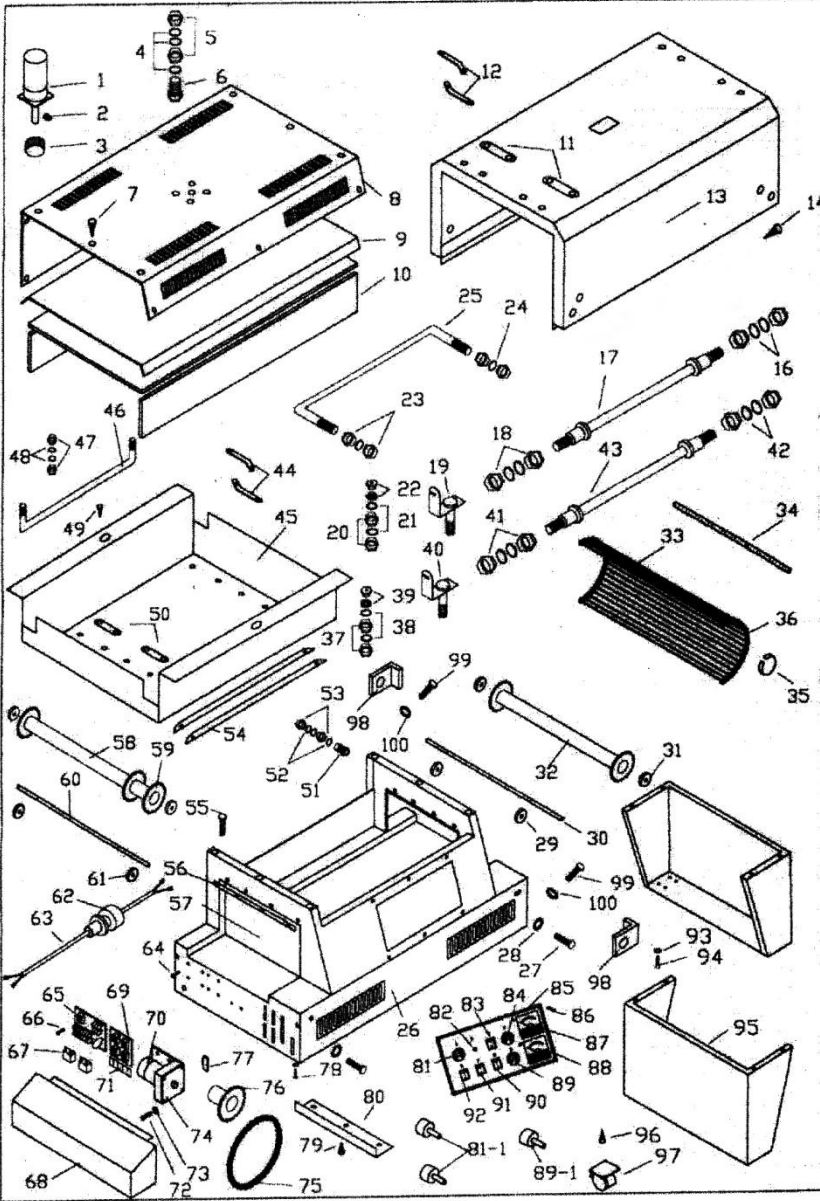

Figure 2. Spare Parts Diagram Overview



**Figure 3. Spare Parts Diagram Overview**

Item	Description	Item	Description	Item	Description
1	Fan Motor	35	E-Type Ring, 184 pcs/tunnel	70	Transmission Motor
2	Socket Heat Set Screw	36	Transmission Chain,4*2LSA-1,184L*36, 2 pcs/tunnel	71	PC Board Bracket
3	Fan	37	Hexagon Nut	74	Motor Bracket
4	Washer	38	Washer	72	Hexagon Head Bolt
5	Hexagon Nut	39	Ceramic Bushing Insulation	73	Washer
6	Bolt Hexagon Head Screw	40	L-Type Bracket for Heater Tube	75	Transmission Chain35RX*44L
7	Tapping Screw	41	Hexagon Nut	76	Transmission Gear
8	Body Cover	42	Washer	77	Socket Heat Set Screw
9	Glass Fiber	43	Heater Tube (17)	78	Tapping Screw
10	Heat Insulating Panel	44	Connecting Brass Strip	79	Tapping Screw
11	I-Type Connecting Brass	45	Stainless Steel Under Tunnel	80	Cover Protecting Hood
12	Connecting Brass	46	U-Type Guard Rail	81	Knob/ Conveyor Potentionmeter
13	Upper Stainless Steel Tunnel	46a	L-Type Guard Rail	81-1	Conveyor Rate Variable Resistance
14	Tapping Screw	47	Hexagon Nut	102	Knob/ Heater Potentiometer
15	Heat Resistance	48	Washer	82	Power Lamp
16	Washer	49	Tapping Screw	83	Switch/ Upper Heater
17	Heater Tube	50	I-Type Connecting Brass Strip	84	Knob/Upper Potentiometer
17a	Ceramic in Heat Tube	51	Hexagon Head Bolt	84-1	Upper Heater Variable Resistance
18	Hexagon Nut	52	Washer	85	Control Panel
19	Heater tube L-Type Bracket	53	Hexagon Nut	86	Tapping Screw
20	Hexagon Nut	54	Track	87	Volt Meter/Upper Heater
21	Washer	55	Tapping Screw (66)	88	Volt Meter/Lower Heater
22	Ceramic Insulating Bushing	56	PTFE Pressing Strip	88a	Volt Meter Cover
23	Hexagon Nut	57	PTFE	89	Knob/ Lower Potentiometer
24	Washer	58	Transmission Gear Shaft	89-1	Lower Heater Variable Resistance
25	U-Type Guard Rail	59	Ball Bearing (same as #31)	90	Switch/4 P, Lower Heater
26	Machine Body	60	Central Shaft	91	Switch/ Two Sides Heater, 4P
27	Hexagon Head Bolt	61	C-Type Ring (same as #29)	92	Conveyor & Fan Switch
28	Washer	62	Cable Glands,Bushing	93	Washer
29	C-type Ring	63	Power Line	94	Hexagon Head Bolt
30	Central Shaft		Thermocouples	95	Supporting Leg
		64	Locking Circuit Board Support	96	Tapping Screw
31	Ball Bearing	101	Magnetic Connector	97	Caster
32	Transmission Gear	66	Tapping Screw	98	Adjustable Clip
33	Bar ,Conveyor Roller, 92 pcs/tunnel	67	Condenser	99	Screw
33a	Conveyor Roller, 80pcs/set	68	Small Cover	100	Washer
34	Silicon Glass Fiber Tube, 92 pcs/tunnel	65	PC Board/Heater, JC-2F098	101	Complete Conveyor 2(#36),92(#34),184(#35),92(#33)
33+34	Conveyor Roller w/sleeve	69	PC Board/Motor/Conveyor	102	Net Type Conveyor Belt