

User Manual

Manual de Usuario

Manuel de l'Utilisateur

Customer Service
US: 1-800-645-2986

Servicio de atención al Cliente
US: 1-800-645-2986

Service à la clientèle
Canada: 888-645-2986

SELF DUMPING FORKLIFT HOPPER

989012
989013
Model 989014

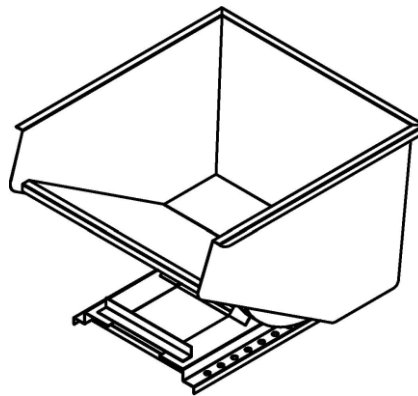

SELF DUMPING FORKLIFT HOPPER						
Model no.	Size [cu.yd]	Capacity [lbs.]	Length	Width	Height	Dump Angle
989012	1	4000	63.9"	44.2"	45"	70°
989013	1-1/2	4000	63.9"	58.0"	39.1"	70°
989014	2	4000	63.9"	58.0"	45"	70°

Please read these instructions completely and save for reference. Upon receiving, inspect the unit for any damage. If damage is evident, notify the carrier immediately to file a claim. These products must be handled with caution by trained operators with proper safety gear and equipment. Failure to comply with instructions could result in serious injury. Please contact global industrial customer service (1-800-645-2986) for any issues.

PRODUCT INFORMATION

Hoppers can be used in industrial spaces for easy waste disposal in commercial properties, medical facilities and more. These Hoppers are made with heavy duty gauge steel for durability, strength, and indoor/outdoor use.

Self Dumping Hoppers are to be used with a fork truck and is released manually through a release latch. The bin returns to normal upright by tilting forks back, then locking both release latch and safety latch. Hoppers rotate 70 degrees and include a safety chain to secure the hopper to the forklift truck.

Product Description

SAFETY INFORMATION

- Only experienced operators with protective gear should be using this product.
- Do not use the hopper if damaged or if any unusual motion is detected or malfunctioning.
- Make sure all warnings and labels are clearly visible.
- Before use, make sure the hopper is fully secured to the forklift and locked in place.
- Do NOT overload or surpass the capacity limit.
- If the hopper does not operate accordingly, STOP operation immediately and inspect the unit.
- No modifications can be made to this unit as this could interfere with function/capacity.
- Operators must comply with OSHA 29 CFR 1910.
- Before work is started or performed, any load on hopper must be removed.
- Before loading the hopper, make sure the hopper is locked in the upright position.
- When unloading the hopper, make sure all **people** are far away from the hopper.

OPERATION

1. Insert the forklift truck's forks completely into the hopper at the backside of the unit.
2. Secure the hopper to the forklift by wrapping the chain around the fork carriage and putting the chain's snap hook through one of the chain links with only a little slack.
3. Position the front of the hopper to one side of the dumpster.
4. The forklift truck mast must then be lifted and tilted forward until the hopper is at the proper height to allow the front part of its frame to touch the dumpster. Make sure there is enough room for the hopper to rotate forward.
5. **To dump, unlock the safety latch and then release hopper with release latch.**
6. After dumping, tilt the forklift truck mast back, **making sure hopper is upright, and then lock both release latch and safety latch.**
7. Move away from the **dumpster** and lower the hopper.

MAINTENANCE

Prior to each use, all procedures **MUST** be followed:

1. Inspect unit to make sure there is no damage or changes.
2. Ensure all cables are in place and fully connected.
3. Make sure there is no unusual noise or any debris/dirt blocking the functionality of the unit.
4. Make sure all latching components/mechanisms work properly and not rusted.
5. Make sure all warning labels are on the unit and clearly visible.
6. Make sure all rods and pins are fully in place.
7. Contact Global Industrial customer service 1-800-645-2986 for any issues.

Product Description



Over 1,000,000 products. Industrial strength service.
We can supply that.

REGISTER ONLINE AT

<http://www.globalindustrial.com/wr> or <http://www.globalindustrial.ca/wr>

Global Limited 1 Year Warranty

1. LIMITED WARRANTY

Global Equipment Company Inc. (DBA Global Industrial) ("Global") hereby warrants to you, the original purchaser and end user ("you" or "your"), that the products that you purchased which accompany this Limited Warranty ("Products") shall be free from defects in materials and workmanship under normal use consistent with the accompanying documentation for 1 year commencing upon the date of purchase (the "Warranty Period").

Global will repair or replace any Product determined to be defective and which has been returned, as set forth in section 3 herein, to Global. A Product may be replaced with a new or used product and/or current or prior revision. Where Global determines in its sole judgment that repair or replacement of such Product is not reasonable, Global will keep the non-conforming Product and refund to you the amount you paid for such Product. Returned Products shall be subject to the balance of the Warranty Period otherwise applicable. Any reconditioned parts used by Global shall be subject to all the same provisions as otherwise applicable to new parts.

THE FOREGOING DESCRIBES THE SOLE LIABILITY OF GLOBAL, AND YOUR SOLE REMEDY, FOR ANY BREACH OF WARRANTY. IF YOU DO NOT AGREE WITH THE TERMS OF THIS LIMITED WARRANTY, YOU MUST RETURN THE PRODUCTS UNUSED AND IN THEIR ORIGINAL PACKAGING WITHIN THREE (3) DAYS AND YOUR PURCHASE PRICE WILL BE REFUNDED.

2. WARRANTY EXCLUSIONS AND LIMITATION OF LIABILITY

This Limited Warranty does not cover: (i) defects or damages resulting from acts of God, casualty, accident, misuse or abuse, overloading, exceeding the recommended weight capacity, neglect, alterations, modification, service or repair by other than Global or its independent third party service providers, including without limitation by you; (ii) improper assembly or installation or de-installation, operation or maintenance, improper connections with peripherals or other causes not arising out of defects in the materials or workmanship of Products; (iii) any Product for which the warranty sticker has been removed, modified or defaced; (iv) shipping containers, batteries, cabinets, media, software or accessories; (v) normal wear and tear; (vi) damage to or loss of repaired or replaced Products during shipping by Global except when such damage or loss is caused by poor or inadequate packaging by Global; or (vii) Products purchased outside the United States or Canada.

UNDER NO CIRCUMSTANCES WILL GLOBAL BE LIABLE FOR ANY LOSS OF USE, INTERRUPTION OF BUSINESS OR ANY INDIRECT, SPECIAL, INCIDENTAL, PUNITIVE OR CONSEQUENTIAL DAMAGES OF ANY KIND (INCLUDING LOST PROFITS) REGARDLESS OF THE FORM OF ACTION WHETHER IN CONTRACT, TORT (INCLUDING NEGLIGENCE), STRICT PRODUCT LIABILITY OR OTHERWISE, EVEN IF GLOBAL HAS BEEN ADVISED OF THE POSSIBILITY OF SUCH DAMAGES. IN NO EVENT SHALL THE TOTAL LIABILITY OF GLOBAL HEREUNDER EXCEED THE GREATER OF \$50 OR THE AMOUNT YOU ACTUALLY PAID FOR THE PRODUCT GIVING RISE TO SUCH LIABILITY, REGARDLESS OF THE CAUSE OF ACTION, IN CONTRACT, TORT, STRICT LIABILITY OR OTHERWISE. NOT ALL JURISDICTIONS ALLOW SUCH LIMITATIONS OF DAMAGES SO THE FOREGOING LIMITATIONS MAY NOT APPLY TO YOU.

3. PROCEDURE FOR WARRANTY SERVICE

Prior to returning any Products to Global for warranty service, you must first contact Global, by telephone at (800) 645-2986 (US) or (888) 645-0878 (Canada) to confirm that such Products are covered by this Limited Warranty. If such Products are so covered, you shall obtain from Global a return materials authorization ("RMA") number and shipping instructions prior to any shipment of such Products to Global, and you must include such RMA number with any corresponding Product shipment, along with a true and correct copy of the original receipt showing the date of Product purchase by you, and a detailed, written description of any associated Product problems.

Please note that you are responsible for all shipping charges incurred in returning an item for exchange or repair. Global shall pay for return shipping of repaired and/or replaced Products to addresses within the United States and Canada only, and return shipments to all other addresses outside of the United States or Canada is your responsibility. If Global determines that any Product is not covered by this Limited Warranty, you must pay all parts, labor charges and return shipping for such Product.

4. WARRANTY DISCLAIMER AND LIMITATIONS

EXCEPT AND TO THE EXTENT EXPRESSLY SET FORTH ABOVE THERE ARE NO WARRANTIES, EXPRESS OR IMPLIED, INCLUDING BUT NOT LIMITED TO, ANY WARRANTIES OF MERCHANTABILITY OR FITNESS FOR A PARTICULAR PURPOSE AND GLOBAL EXPRESSLY DISCLAIMS ALL WARRANTIES NOT STATED HEREIN.

EXCEPT AND TO THE EXTENT EXPRESSLY SET FORTH ABOVE, THE PRODUCTS ARE PROVIDED ON AN "AS IS" BASIS, AND GLOBAL MAKES NO ADDITIONAL WARRANTIES, EXPRESS, IMPLIED, ARISING FROM COURSE OF DEALING OR USAGE OF TRADE, OR STATUTORY, AS TO THE PRODUCTS OR ANY MATTER WHATSOEVER. THIS IS A LIMITED WARRANTY AND IS THE ONLY WARRANTY MADE BY GLOBAL. THE AGENTS, EMPLOYEES, DISTRIBUTORS, AND DEALERS OF GLOBAL ARE NOT AUTHORIZED TO MAKE MODIFICATIONS TO THIS LIMITED WARRANTY, OR MAKE ADDITIONAL WARRANTIES BINDING ON GLOBAL. ACCORDINGLY, ADDITIONAL STATEMENTS SUCH AS DEALER ADVERTISING OR PRESENTATION, WHETHER ORAL OR WRITTEN, DO NOT CONSTITUTE WARRANTIES BY GLOBAL AND SHOULD NOT BE RELIED UPON. GLOBAL DOES NOT WARRANT THAT THE PRODUCTS WILL OPERATE WITHOUT FAILURE, OR THAT THE PRODUCTS WILL MEET YOUR NEEDS OR EXPECTATIONS. NOT ALL JURISDICTIONS ALLOW SUCH WARRANTY LIMITATIONS SO THE FOREGOING LIMITATIONS MAY NOT APPLY TO YOU.

5. CHOICE OF LAW AND JURISDICTION

FOR PURCHASES WITHIN THE US - This Limited Warranty shall be subject solely to the laws of the State of New York as applied to contracts entered into in the State of New York between New York residents. Any dispute arising hereunder shall be subject to the sole jurisdiction of the State and Federal Courts located in Nassau County, New York. The parties hereby consent to the personal jurisdiction of such courts.

FOR PURCHASES WITHIN CANADA - This Limited Warranty shall be subject solely to the laws of the Province of Ontario. Any dispute arising hereunder shall be subject to the sole jurisdiction of Ontario, Canada. The parties hereby consent to the personal jurisdiction of such courts.

