

Magnetic Sweeper Instruction Manual

Easily pick up and release nails, screws, paper clips, and more. It can be used for sweeping factory aisles, shop aisles, construction sites, walkways, loading docks, parking lots, etc.

Assembly Instructions

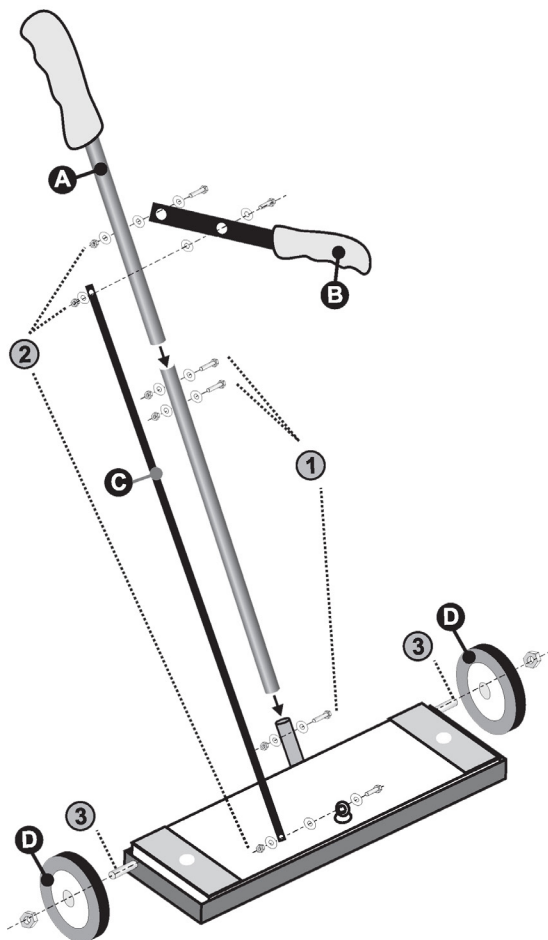

1. ATTACH HANDLE TO MAGNET BASE

Attach the handle with the 2 hex screws and nuts. Slide the open end of the Handle(A) over the stem and align the holes. Insert hex bolt and secure from the underside with a locking hex nut. Tighten firmly.

2. ATTACH RELEASE BAR

Attach top of Release Bar(C) to the lever(B) by aligning holes and placing a hex bolt through a washer and into the hole Lever(B). Place a washer between the Release Bar(C) and Lever(B), then secure with washer and locking hex nut. For the bottom of the Release Bar(C), align the eye bolt hole with a washer and then place the hex bolt into eye bolt. Place washer between the eye bolt and both sides of the Release Bar(C) and secure with a locking hex nut.

3. ATTACH WHEEL

Slide each 6" Wheel(D) onto the threaded bolts on both sides of the bottom and secure with hex nuts. Note: Do not over tighten or else wheels won't spin freely

Package Content

- 1 x Magnetic Sweeper Base
- 1 x 26.4" & 25.2" Handle
- 1 x 33" & 13.4" Release Lever
- 2 x 6" Wheels
- 2 x <1> 20 Gaskets
- 14 x <l>15 Gaskets
- 6 x M6 Hex Screws
- 7 x M6 Lock nuts

Model #	Description
641796	Global Industrial™ 24" Heavy Duty Magnetic Sweepers with Release Lever
641797	Global Industrial™ 36" Heavy Duty Magnetic Sweepers with Release Lever

To release the iron parts, lift the releasing handle to lift the magnetic base as shown on the right

