

Assembly Instructions	Instrucciones de Ensamblaje	Directives d'assemblage
Customer Service US: 1-800-645-2986	Servicio de atención al Cliente México: 01.800.681.6940	Service à la clientèle Canada: 888-645-2986

Laptop Mobile Computer Workstation

Model 695421

CONTENTS		
Ref.	Qty.	Description
1	1	Caster Base
2	1	Lower Post
3	1	Top Post
4	2	Joiner
5	1	Laptop Tray
6	1	Support Bar
7	1	Mouse Pad Support
8	1	Mouse Holster
9	1	Laptop Hold Down Bar
H1	2	Non Locking Caster
H2	3	Locking Caster
H3	1	Fender Washer
H4	1	M8 x 125 x 36mm Lg. Hex Socket Head Bolt
H5	1	5.5mm Hex Key
H6	4	M4 x 16mm Lg. Set Screw
H7	1	2mm Hex Key
H8	1	M6 x 1.0 Sq. Spring Nut
H9	1	M6 x 1.0 x 20mm T- Handle Knob
H10	1	8mm Id. x 17mm Od. Plain Washer
H11	1	8mm Id. x 23mm Od. Plain Washer
H12	2	4mm Thumb Screw
H13	1	Cable Holder
H14	1	End Cap
H15	1	M4 x .07 Hex Nut
H16	2	M4 x .07 x 16mm Lg. Hex Socket Screw
H17	1	3mm Hex Key
H18	1	M4 x .07 Hex Nylon Lock Nut
H19	3	4.5mm Id. x 12mm Od. Plain Washer

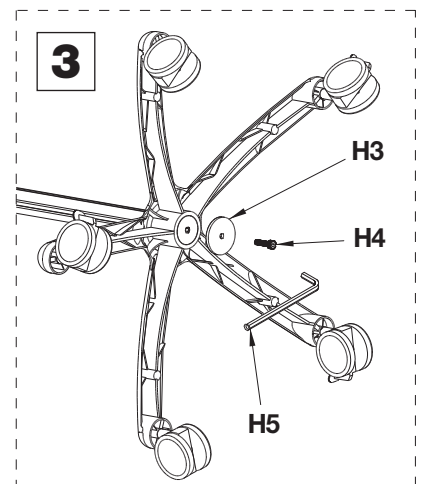
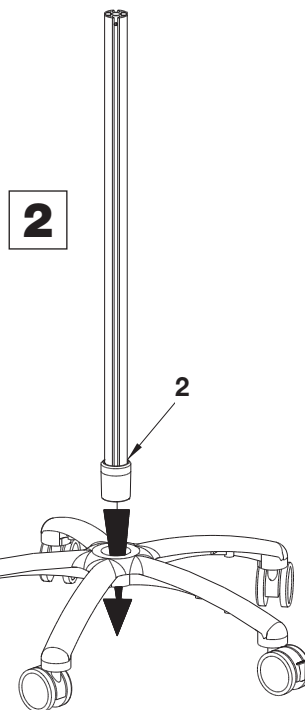
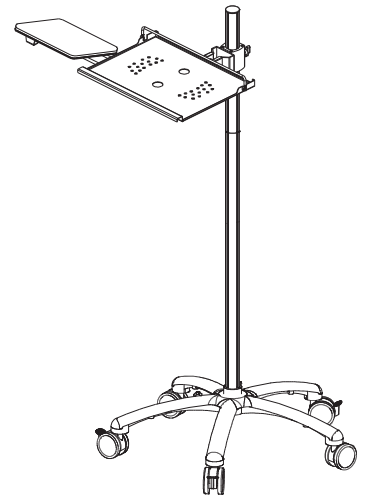
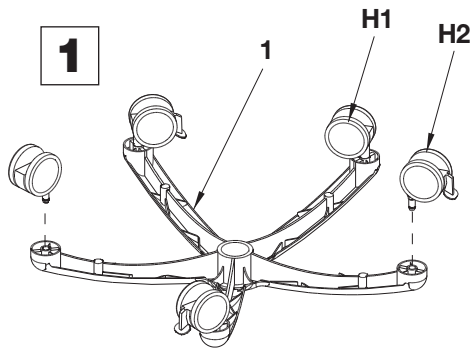

Laptop Mobile Computer Workstation

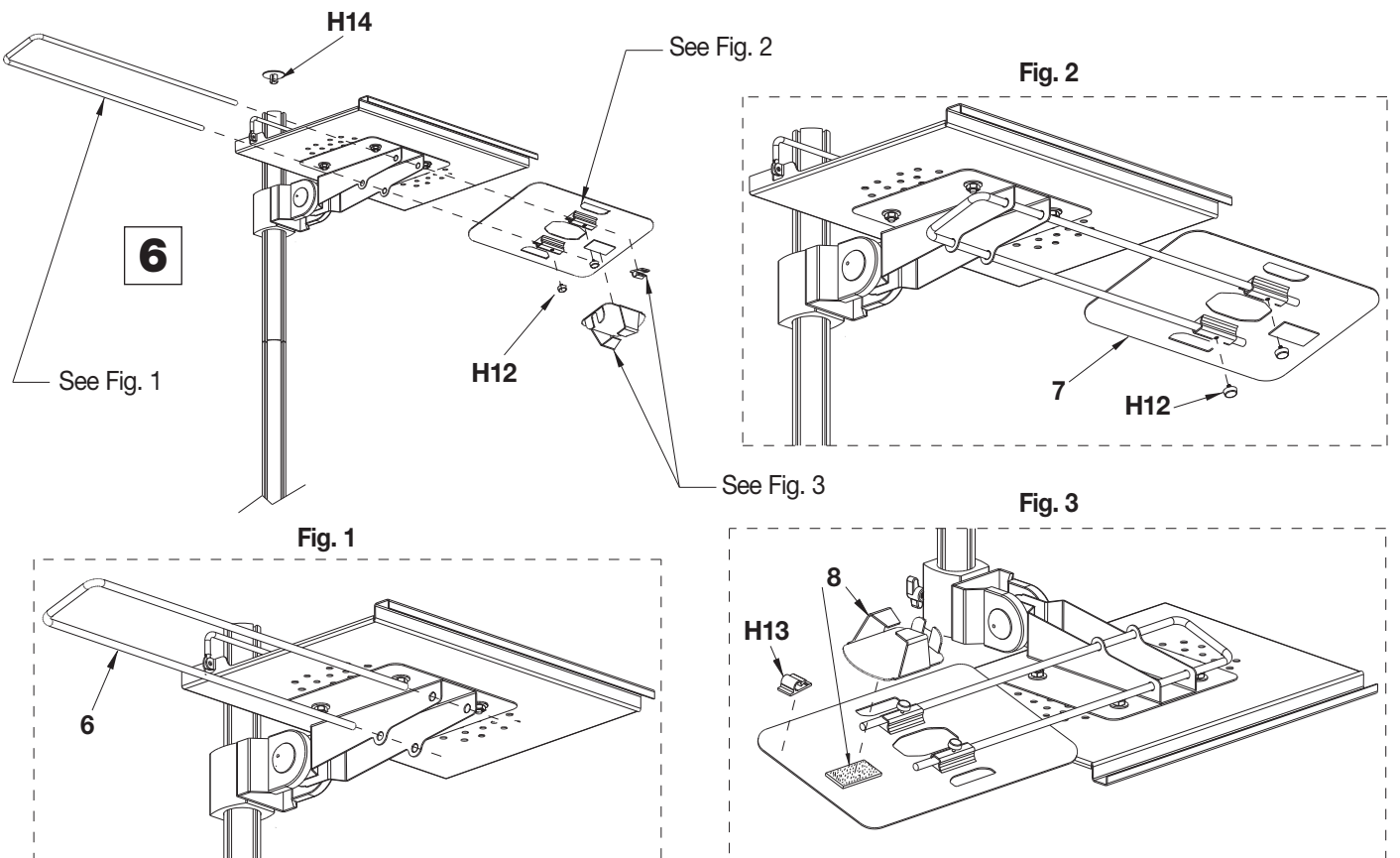
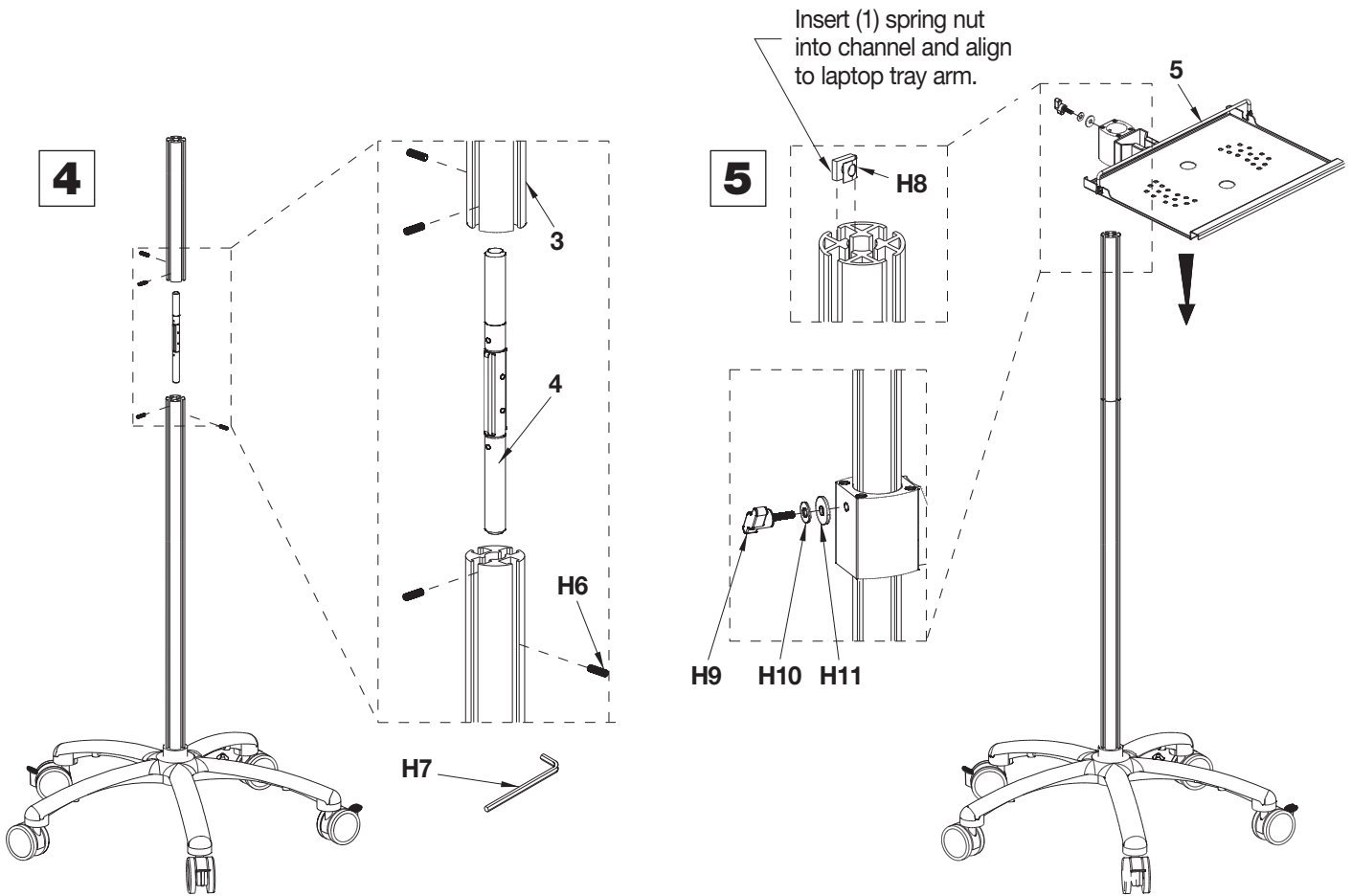

Laptop Mobile Computer Workstation

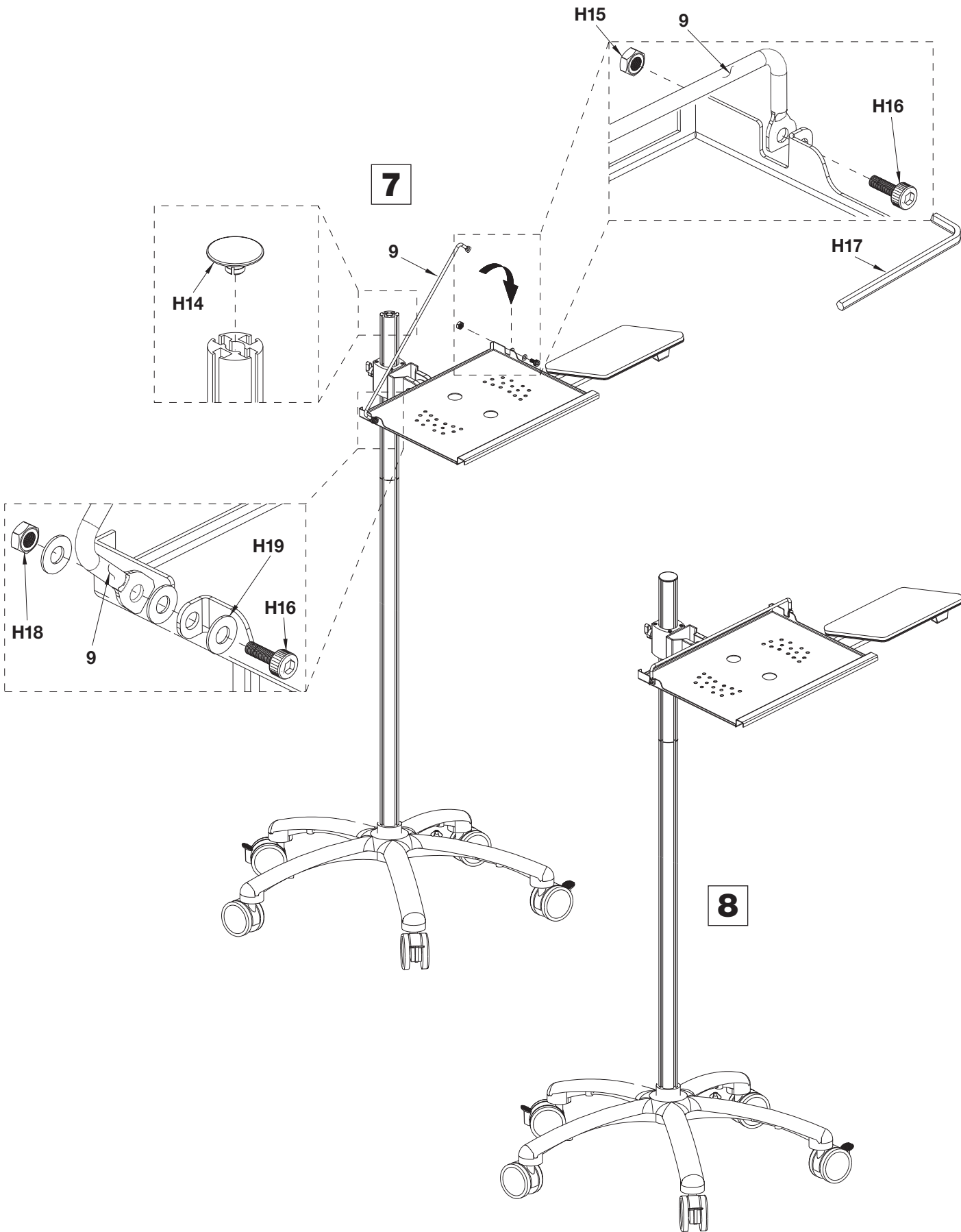

Laptop Mobile Computer Workstation

OPTIONAL ACCESSORIES

CONTENTS		
Ref.	Qty.	Description
1	1	Printer Stand
2	2	Support Bracket
H1	1	M6 x 1.0 Sq. Spring Nut
H2	1	M6 x 1.0 x 20mm T-Handle Knob
H3	1	8mm Id. x 17mm Od. Plain Washer
H4	1	8mm Id. x 23mm Od. Plain Washer
H5	4	M6 x 1.0 Wing Nut
H6	4	7mm Id. x 15mm Od. Plain Washer
H7	4	35mm x 20mm x 5mm Cushion

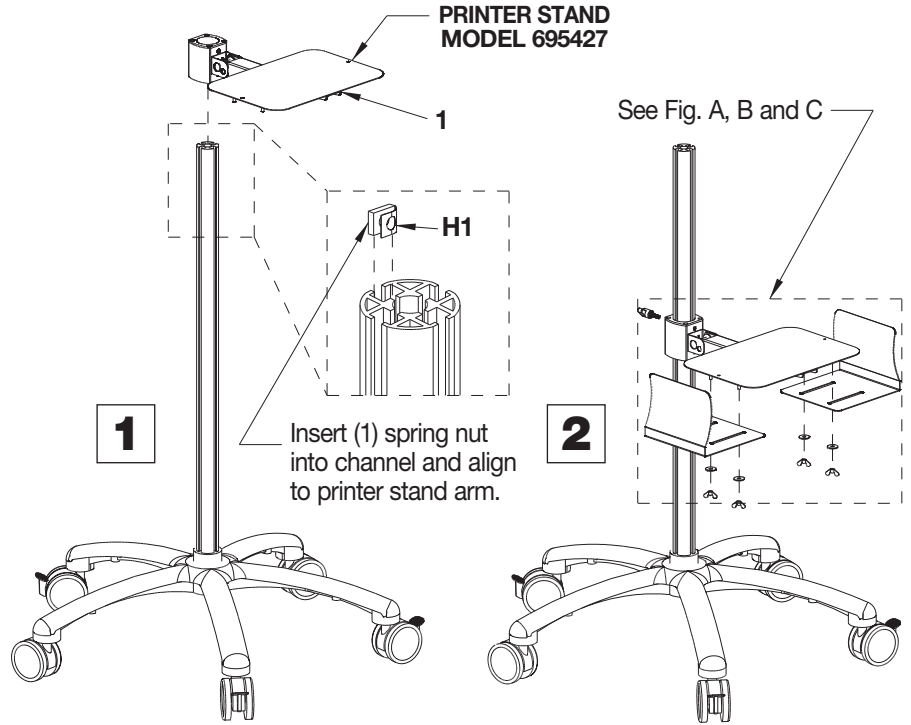
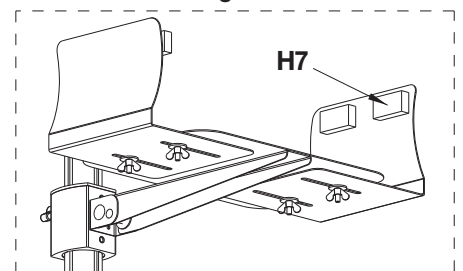
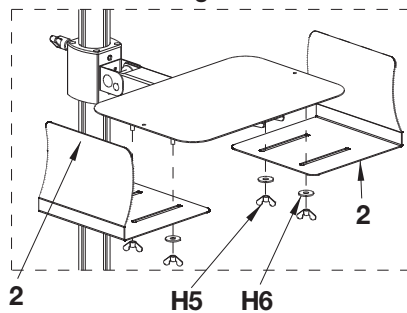
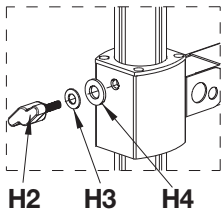

Fig. B

Fig. C

Fig. A



CONTENTS		
Ref.	Qty.	Description
1	1	Paper Tray
H1	2	M6 x 1.0 Sq. Spring Nut
H2	2	M6 x 1.0 x 10mm Lg. Phillips Pan Head Screw

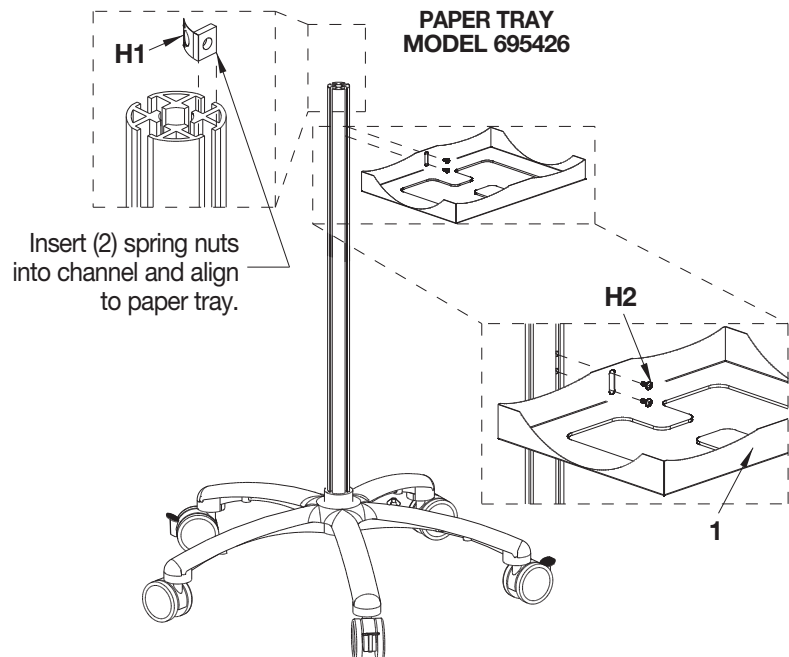

Assembly Instructions

Instrucciones de Ensamblaje

Directives d'assemblage

Customer Service
US: 1-800-645-2986

Servicio de atención al Cliente
México: 01.800.681.6940

Service à la clientèle
Canada: 888-645-2986

Ordenador portátil móvil con estación de trabajo

Modelo 695421

CONTENIDO		
Ref.	Cant.	Description
1	1	Base de Ruedas
2	1	Poste inferior
3	1	Poste superior
4	2	Ensamblador
5	1	Bandeja de Computadora Portátil
6	1	Barra de Soporte
7	1	Alfombrilla de Soporte para el ratón
8	1	Funda para el ratón
9	1	Barra de Mantenimiento para Computadora Portátil
H1	2	Rueda Anti-Bloqueo
H2	3	Rueda para Bloquear
H3	1	Arandela de Defensa
H4	1	Perno hexagonal de cabeza hueca M8 x 125 x 36mm de largo
H5	1	Llave hexagonal de 5.5mm
H6	4	Tornillo de Ajuste M4 x 16mm de largo.
H7	1	Llave hexagonal 2mm
H8	1	Tuerca de resorte M6 x 1.0 Sq.
H9	1	Perilla de Mango tipo T M6 x 1.0 x 20mm
H10	1	Arandela Plana 8mm Id. x 17mm Od.
H11	1	Arandela Plana 8mm Id. x 23mm Od.
H12	2	Tornillo de Muletilla 4mm
H13	1	Soporte de Cable
H14	1	Tapa de extremo
H15	1	Tuerca hexagonal M4 x .07
H16	2	Tornillo Hexagonal M4 x .07 x 16mm de largo
H17	1	Llave Hexagonal 3mm
H18	1	Tuerca hexagonal de cierre de nylon M4 x .07
H19	3	Arandela Plana 4.5mm Id. x 12mm Od.

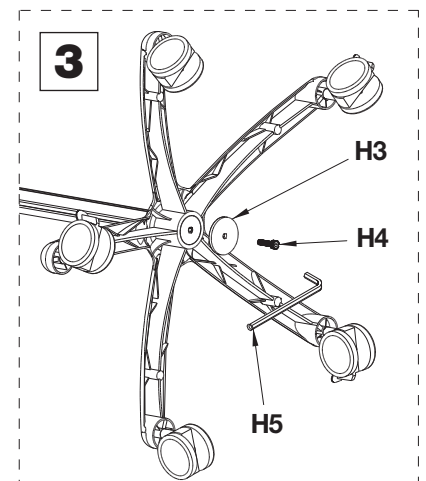
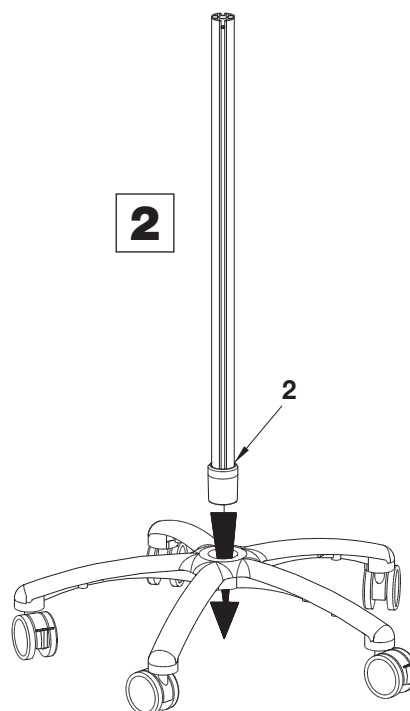
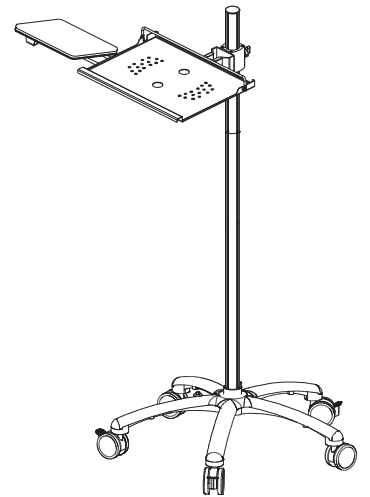
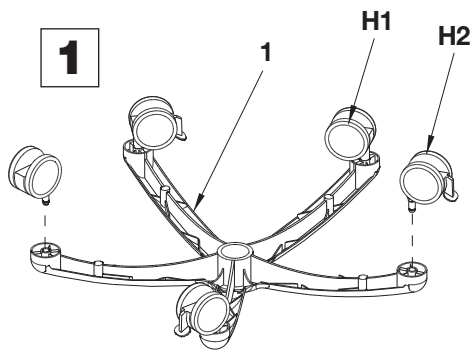

Ordenador portátil móvil con estación de trabajo

Inserte (1) tuerca de resorte al canal y alinee hacia el brazo de la bandeja de la computadora portátil.

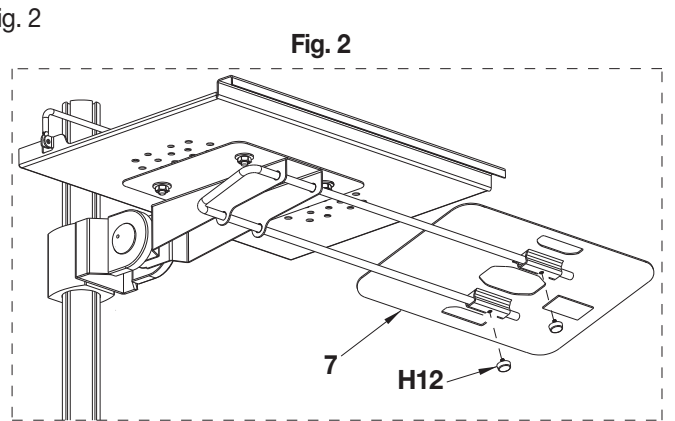
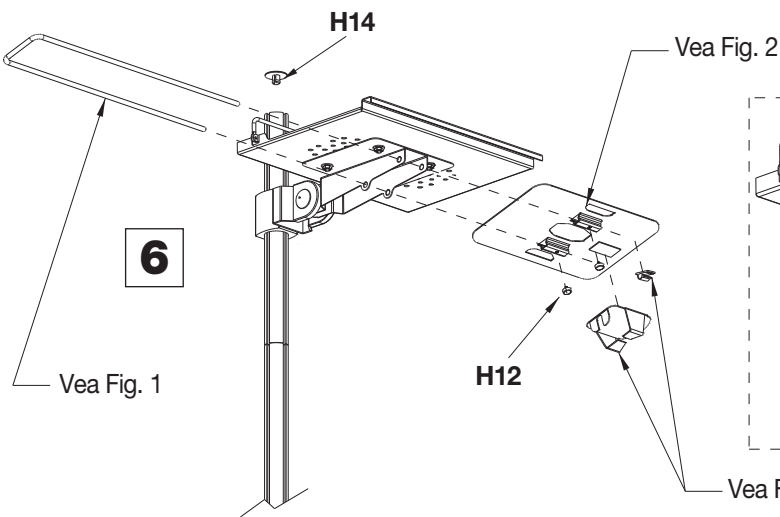
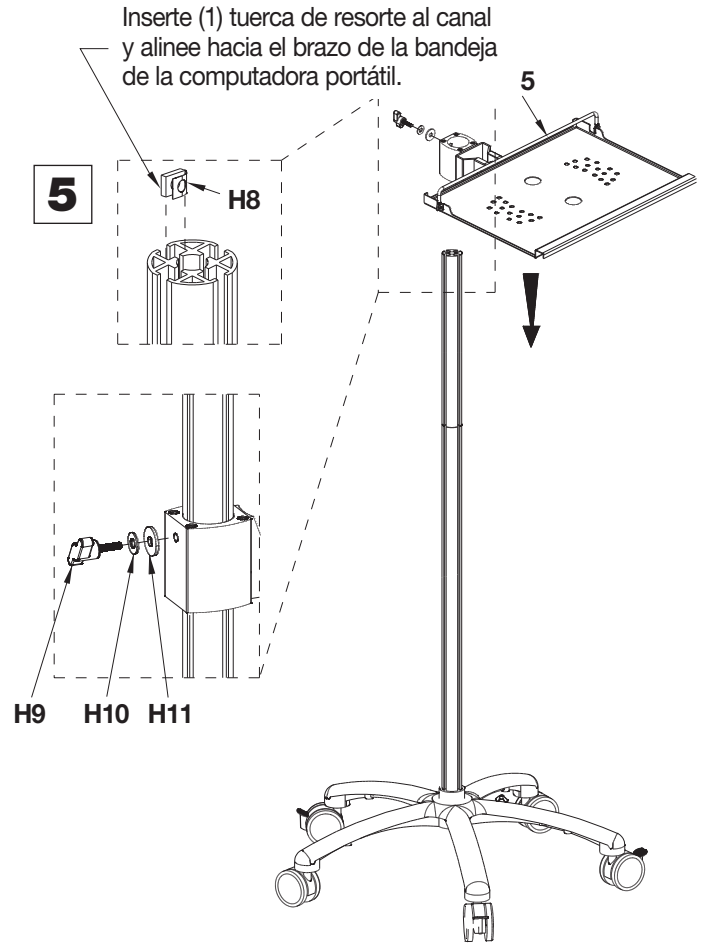
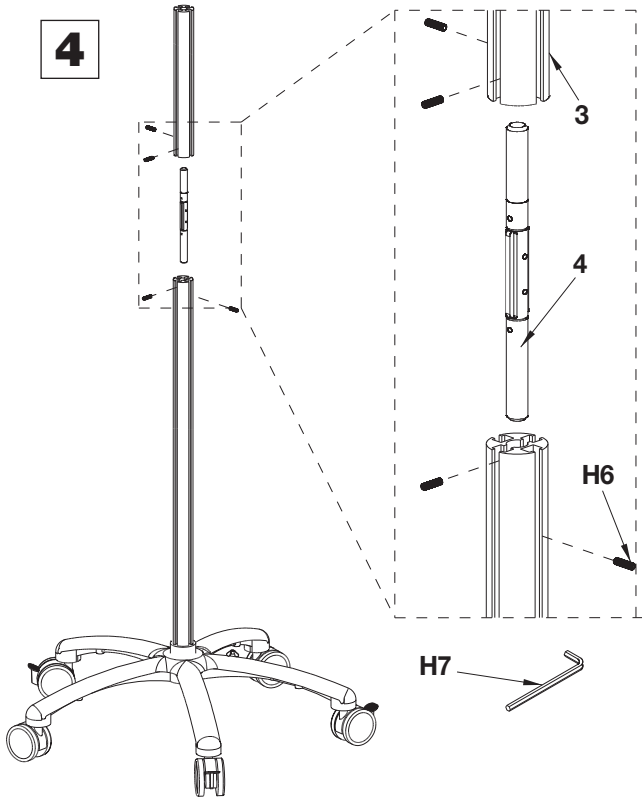

Vea Fig. 3

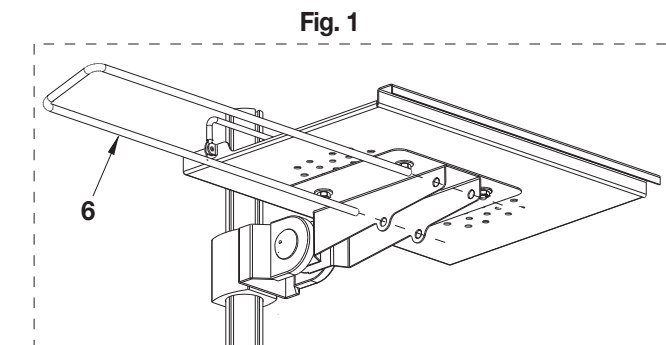

Fig. 1

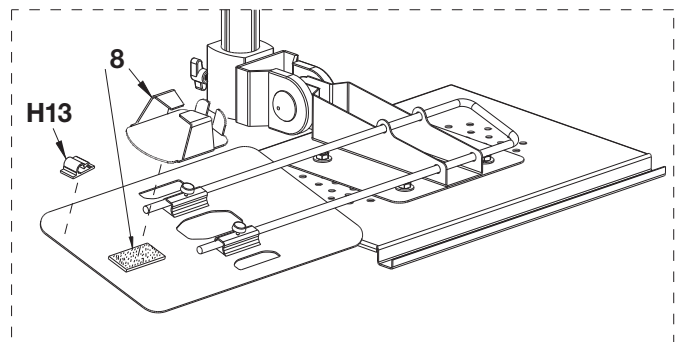
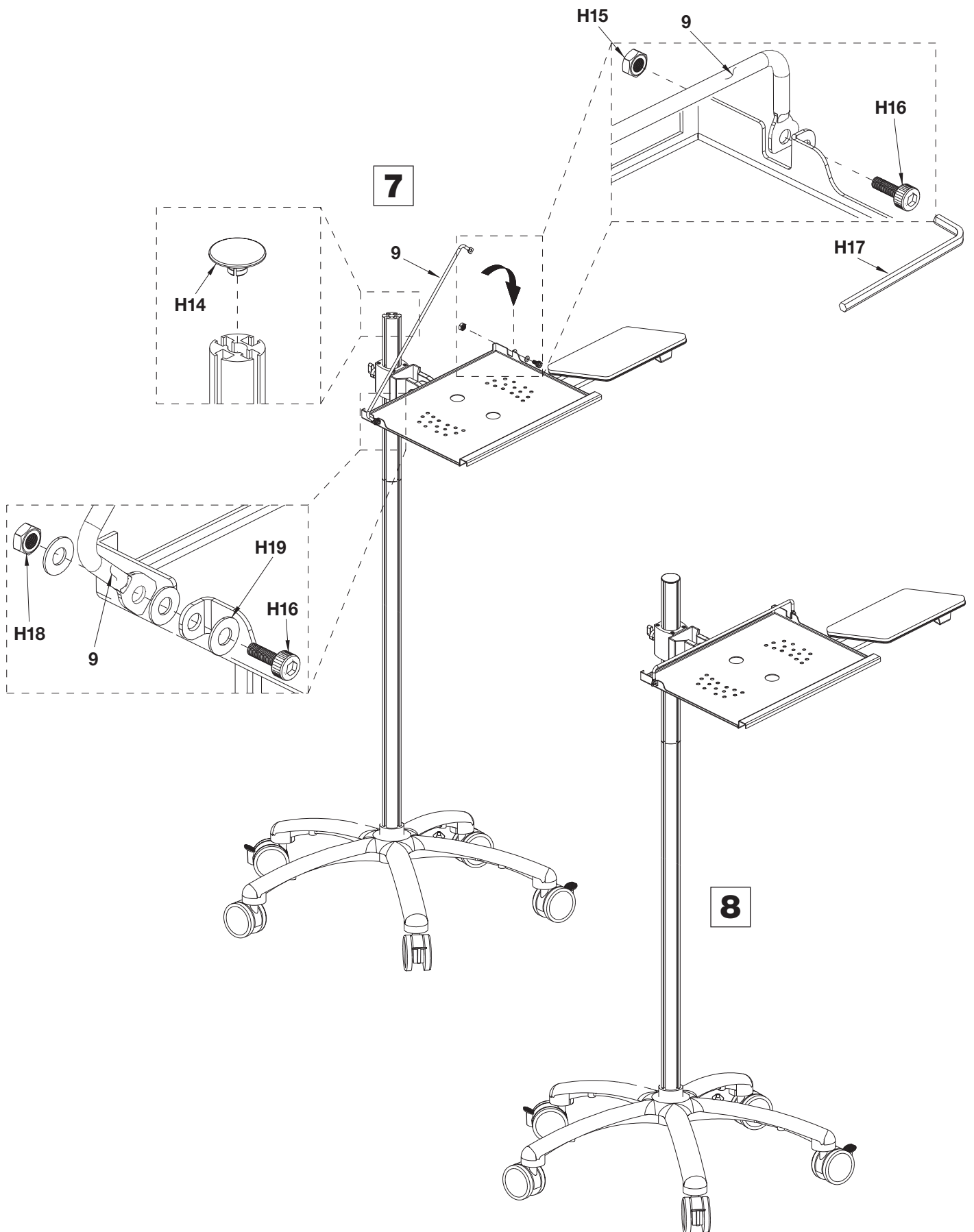

Fig. 3

Ordenador portátil móvil con estación de trabajo



Ordenador portátil móvil con estación de trabajo

ACCESORIOS OPCIONALES

CONTENIDO		
Ref.	Cant.	Description
1	1	Soporte para Impresora
2	2	Soporte Angular
H1	1	Tuerca de resorte M6 x 1.0 Sq.
H2	1	Mango con Perilla en forma de T M6 x 1.0 x 20mm
H3	1	Arandela Plana 8mm Id. x 17mm Od.
H4	1	Arandela Plana 8mm Id. x 23mm Od.
H5	4	Tuerca de Mariposa M6 x 1.0
H6	4	Arandela Plana 7mm Id. x 15mm Od.
H7	4	Cojín 35mm x 20mm x 5mm

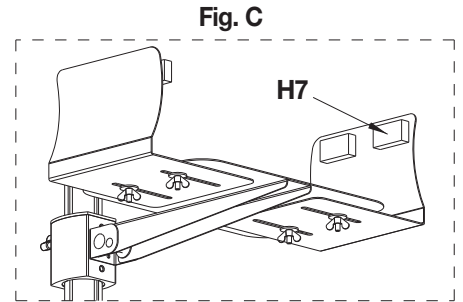
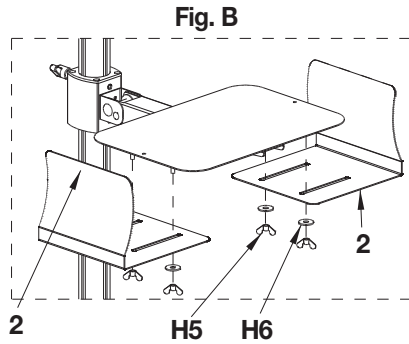
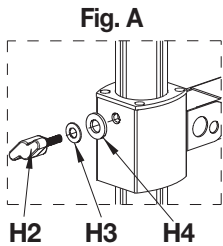
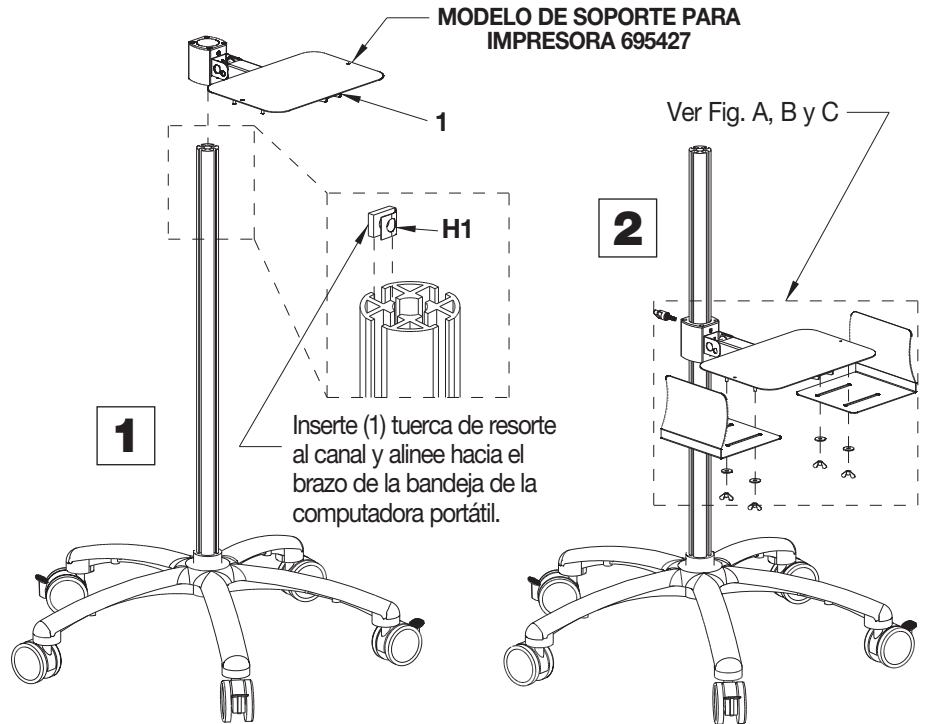

CONTENIDO		
Ref.	Cant.	Description
1	1	Bandeja del Papel
H1	2	Tuerca de Resorte M6 x 1.0 Sq.
H2	2	Tomillo de cabeza troncocónica Phillips M6 x 1.0 x 10mm de largo

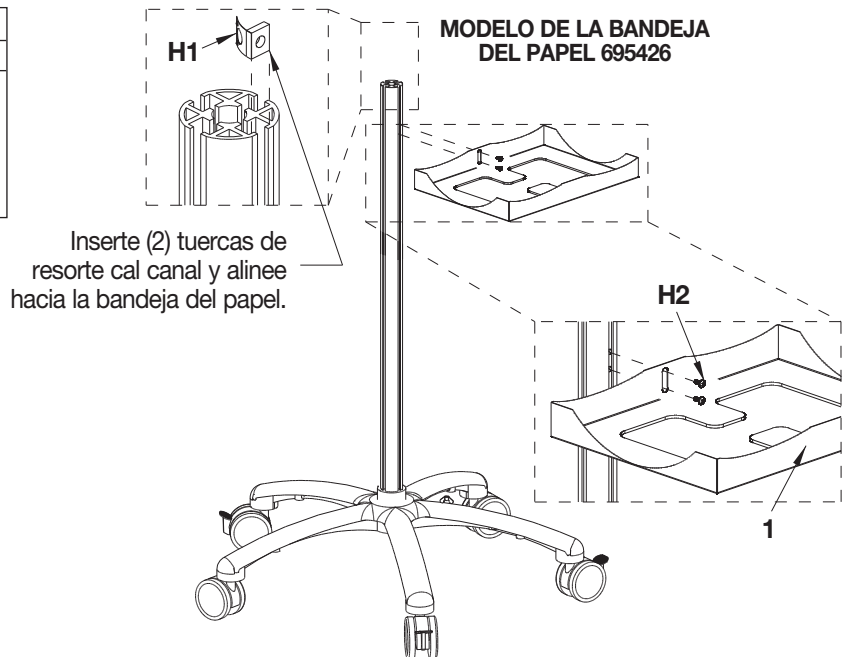

Assembly Instructions	Instrucciones de Ensamblaje	Directives d'assemblage
Customer Service US: 1-800-645-2986	Servicio de atención al Cliente México: 01.800.681.6940	Service à la clientèle Canada: 888-645-2986

Poste de travail de portable mobile

Modèle 695421

CONTENU		
Réf.	Qté.	Description
1	1	Socle à roulettes
2	1	Poteau inférieur
3	1	Poteau supérieur
4	2	Assembleur
5	1	Plateau du portable
6	1	Barre de support
7	1	Soutien du Tapis de souris
8	1	Étui pour souris
9	1	Barre de soutien du portable
H1	2	Roulette sans verrou
H2	3	Roulette à verrou ...
H3	1	Rondelle de protection
H4	1	M8 x 125 x 36mm Lg. Écrou avec douille à tête hex.
H5	1	Clé hexagonale 5.5mm ...
H6	4	M4 x 16mm Lg. Vis de serrage
H7	1	Clé hexagonale 2mm ...
H8	1	Écrou à ressort M6 x 1.0 Sq.
H9	1	Bouton en T M6 x 1,0 x 20mm
H10	1	Diamètre de 8mm x 17mm Rondelle plate
H11	1	Diamètre de 8mm x 23mm Rondelle plate
H12	2	Écrou moleté 4mm
H13	1	Support de câble
H14	1	Embout
H15	1	Vis hexagonale M4 x 07
H16	2	M4 x .07 x 16mm Lg. Vis pour douille hexagonale
H17	1	Clé hexagonale 3mm
H18	1	Écrou hexagonal à verrou M4 x 07 Sq.
H19	3	Rondelle de dia. de 4,5mm Id. x 12mm

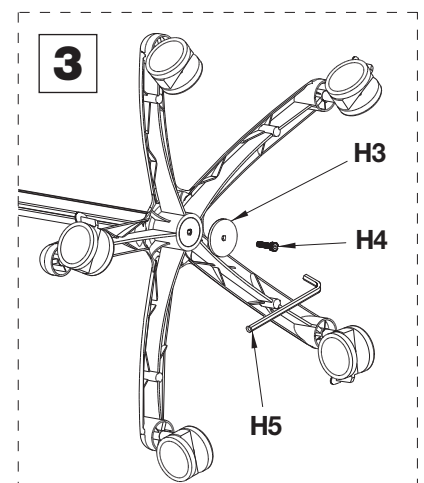
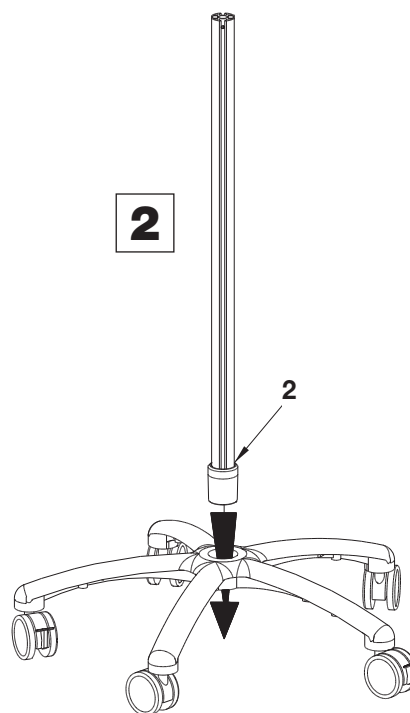
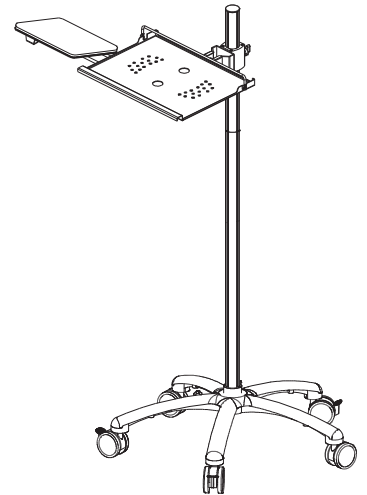
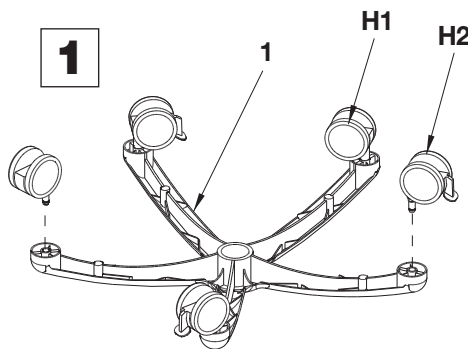

Poste de travail de portable mobile

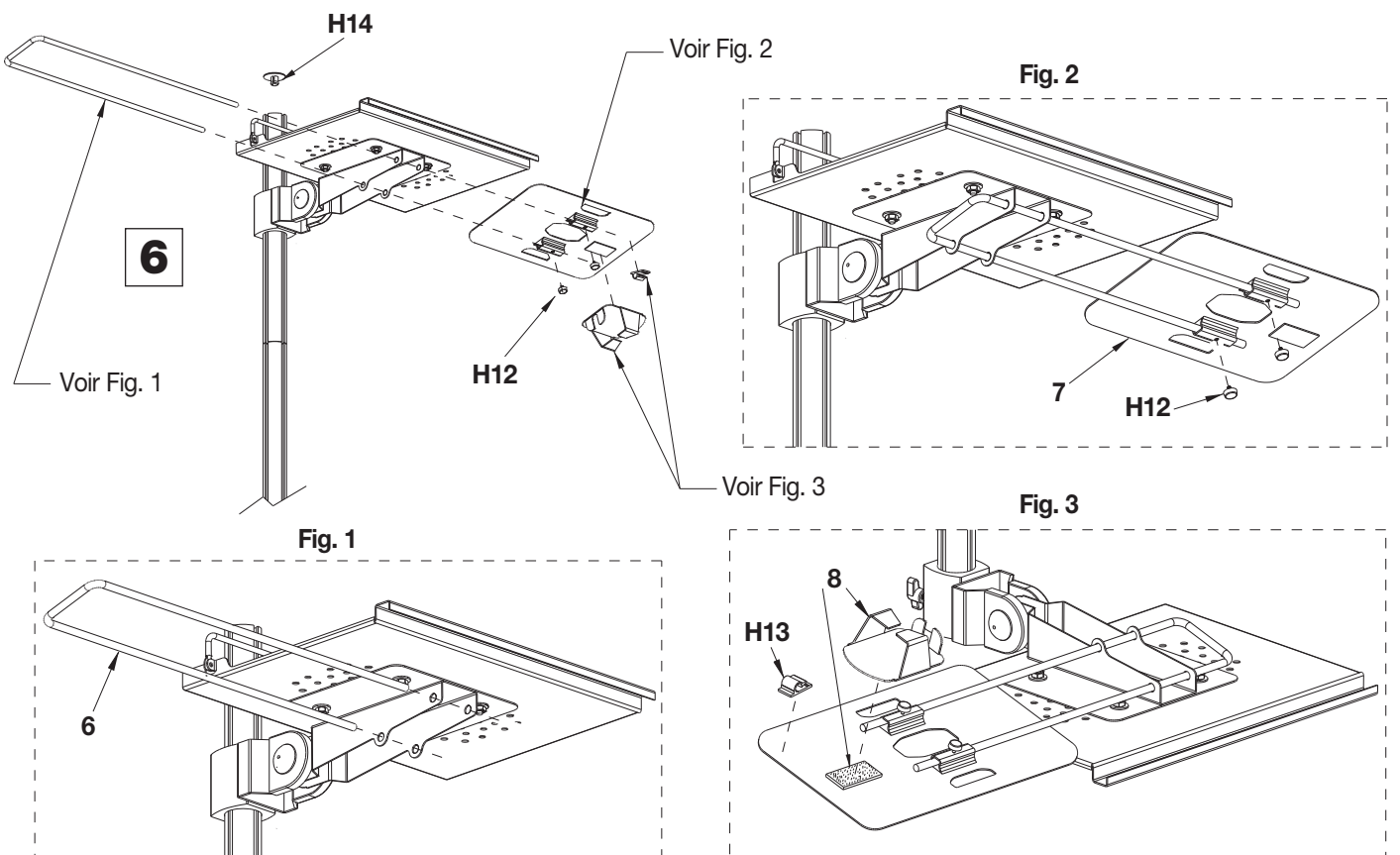
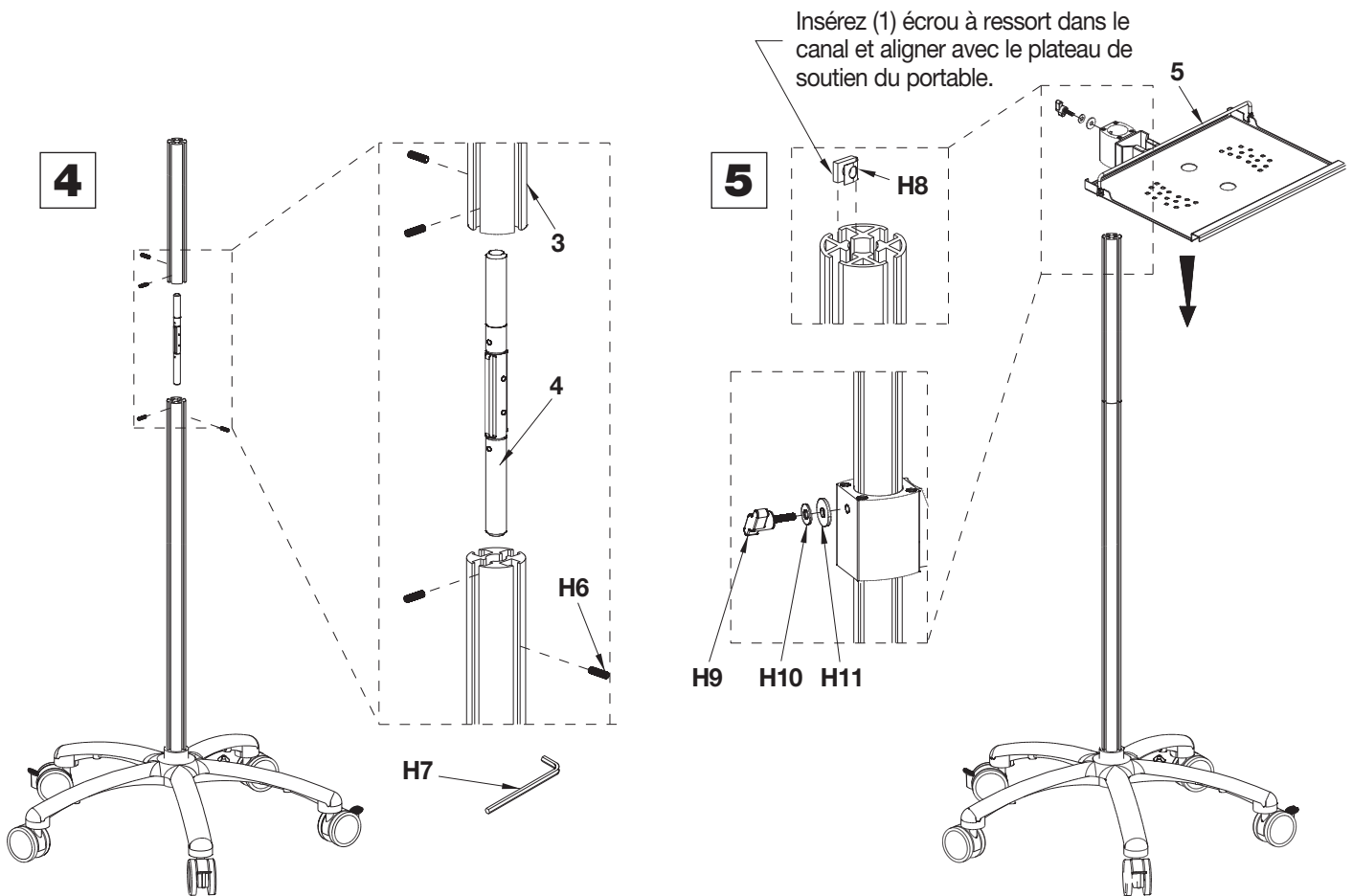

Poste de travail de portable mobile

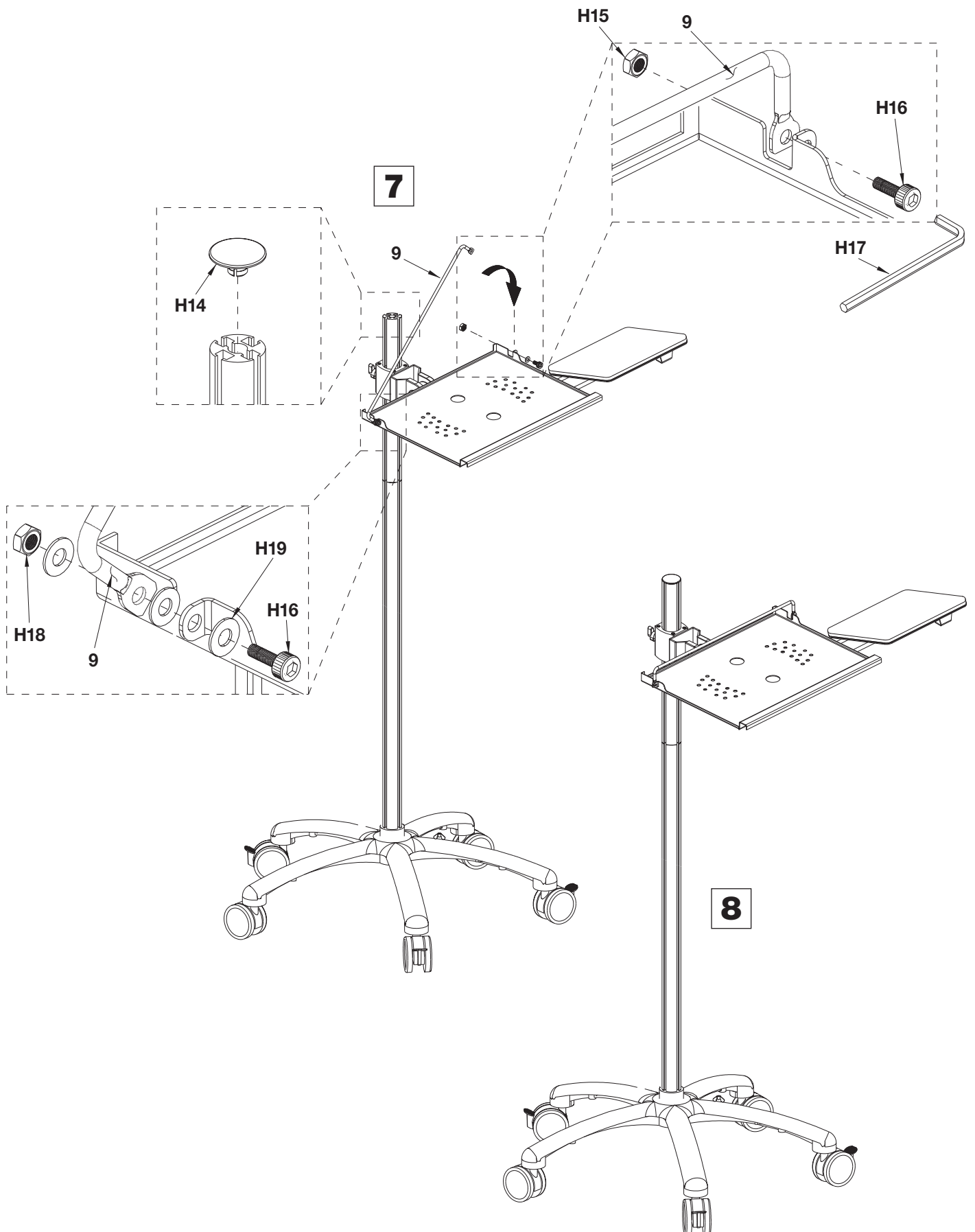

Poste de travail de portable mobile

ACCESSOIRES OPTIONNELS

CONTENU		
Réf.	Qté.	Description
1	1	Support d'imprimante
2	2	Fixation de soutien
H1	1	Vis à ressort M6 x 1.0
H2	1	Bouton en T..... M6 x 1,0 x 20mm
H3	1	Rondelle de dia. de 8 mm Id. x 17mm
H4	1	Rondelle de dia. de 8 mm Id. x 23mm
H5	4	Vis papillon..... M6 x 1.0
H6	4	Diamètre de 7mm x 15mm Rondelle plate
H7	4	Coussin de 35mm x 20mm x 5mm

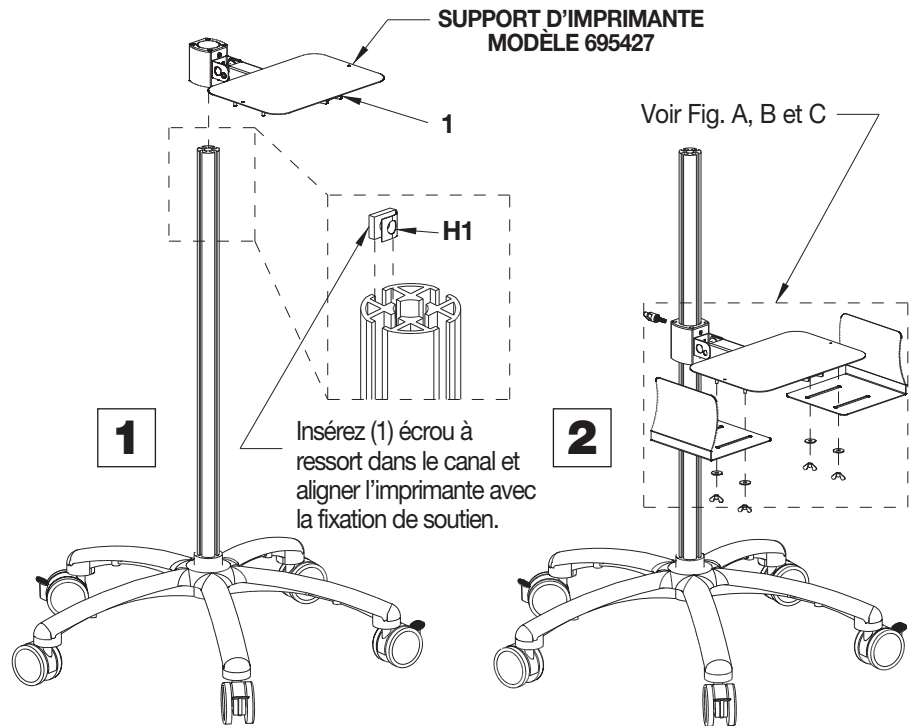
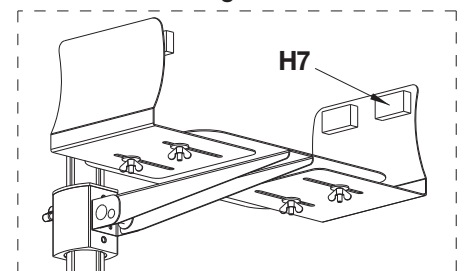
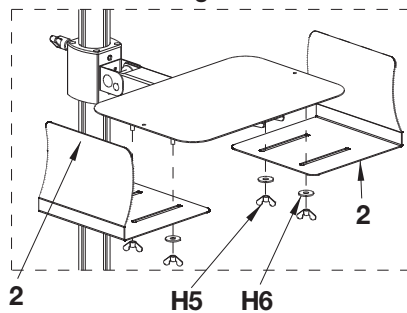
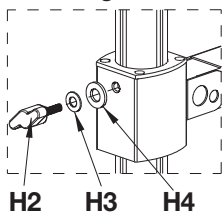

Fig. B

Fig. C

Fig. A



CONTENU		
Réf.	Qté.	Description
1	1	Plateau pour papier
H1	2	Vis à ressort M6 x 1.0
H2	2	M6 x 1,0 x 10mm Lg. Vis cylindrique cruciforme

