



**GLOBALTM
INDUSTRIAL**

We can supply that.[®]

User's manual

Manual del usuario

Manuel de l'utilisateur

Customer Service
US: 1-800-645-2986

Servicio de atención al Cliente
US: 1-800-645-2986

Service à la clientèle
Canada: 888-645-2986

Floor Standing Drill Press

Model(s): 257274



SPECIFICATIONS

Motor:	1100W
Capacity:	1 1/4"
Speed:	12
Frequency:	60Hz
Voltage:	120V

! WARNING

Read and understand all instructions before operating this machine. Failure to follow these instructions may result in electric shock, fire, and/or serious injury

Floor Standing Drill Press

SAFETY INSTRUCTIONS

1. Keep your work area clean and well lit. Always keep the work area free of obstructions, grease, oil, trash, and other debris.
2. Never operate this machine in the presence of flammable liquids, gases, or dust. Power tools create sparks which may ignite the dust or fumes.
3. Keep bystanders, children, and visitors away while operating this machine. Distractions can lead to serious injury or property damage. Protect others in the work area from debris such as chips and sparks. Provide barriers or shields as needed.
4. Never leave drill press unattended while running.
5. Do not touch grounded surfaces such as pipes, radiators, ranges, and refrigerators when operating on electrical components. There is an increased risk of electric shock if your body is grounded.
6. Do not expose the machine to water. Water entering a power tool will increase the risk of electric shock.
7. Grounded tools must be plugged into an outlet properly installed and grounded in accordance with all local codes and ordinances. Never remove the grounding prong or modify the plug in any way. Do not use adapter plugs. Check with a qualified electrician if you are unsure if the outlet is properly grounded. If the tools should electrically malfunction, grounding provides a low resistance path to carry electricity away from the user.
8. Do not use drill press if power switch does not work. Cease operation and repair switch or replace drill press.
9. Keep the Power Cord away from heat, oil, sharp edges, or moving parts. Cease operation and replace Power Cords immediately if damaged.
10. Disconnect power cord before making any adjustments, maintenance, or storing the machine.
11. Avoid Accidental start-ups, make sure power switch is in "OFF" position before plugging in the power cord.
12. Never use this machine when tired or under the influence of drugs, alcohol, or medication.
13. Dress properly. Do not wear loose clothing or jewelry. Contain long hair. Keep your hair, clothing, and gloves away from moving parts. Loose clothes, jewelry, or long hair can be caught in moving parts and may cause serious personal injury.
14. Remove adjusting keys or wrenches before turning the drill press on. A wrench or a key that is left attached to a rotating part of the machine is dangerous may result in personal injury.
15. Do not start the motor with the drill bit touching the workpiece, this can cause the workpiece to catch and spin with the bit. Allow the bit to come up to full speed before you begin drilling.
16. Use safety equipment, drill presses can produce sharp chips which can cause permanent eye damage if lodged in the eye. Wear ANSI Z87+ safety glasses or goggles for protection.
17. Secure the workpiece using clamps or a vise whenever possible. Especially when drilling large holes, or any size hole in sharp objects or sheet metal, the workpiece may become a hazard if it is caught and rotated by the drill bit. Clamping the workpiece is more secure than using your hands and keeps them out of harm's way.
18. Do not use third party or aftermarket accessories, they may impair operation of the drill press or malfunction during normal use.
19. Maintain all labels and nameplates on the machine so that they are clearly visible and legible.

Floor Standing Drill Press

OPERATION INSTRUCTIONS

1. Install the machine on a flat, level floor that is sturdy enough to support the weight and vibrations of the drill press.
2. Always wear protective safety glasses or goggles when operating the machine.
3. Clear woodchips, sawdust and metal chips before operation.
4. Make sure head and table supports are secure before drilling
5. Check all nuts, bolts and screws for tightness regularly. Vibration during operation may cause hardware to loosen.
6. Use the correct drill bit. Ensure that you have selected the correct drill bit and drill speed based on the workpiece's material and thickness. Ensure that there are no nails or other hard objects in the path of the drill bit. Take care not to force the drill bit, you may permanently damage the bit and the workpiece.
7. Do not use a drill bit longer than 175mm (150mm outside chuck jaws).
8. Do not place drill bit against workpiece before turning power switch on. Turn on the drill before and allow the bit to come up to full speed before drilling.
9. Make sure you are drilling at the correct speed based on hole size and workpiece material.
10. Make sure there are no nails or other hard obstacles in the way of the drill bit inside the workpiece
11. Jog the motor before drilling to ensure that drill bit is secure and motor is in working order.
12. Hold workpiece securely at a safe distance from the drill bit or use clamps or vise. Never drill into an unsecured workpiece.



Floor Standing Drill Press

ASSEMBLY INSTRUCTIONS

Parts List

Note: Confirm that you have all components before beginning assembly

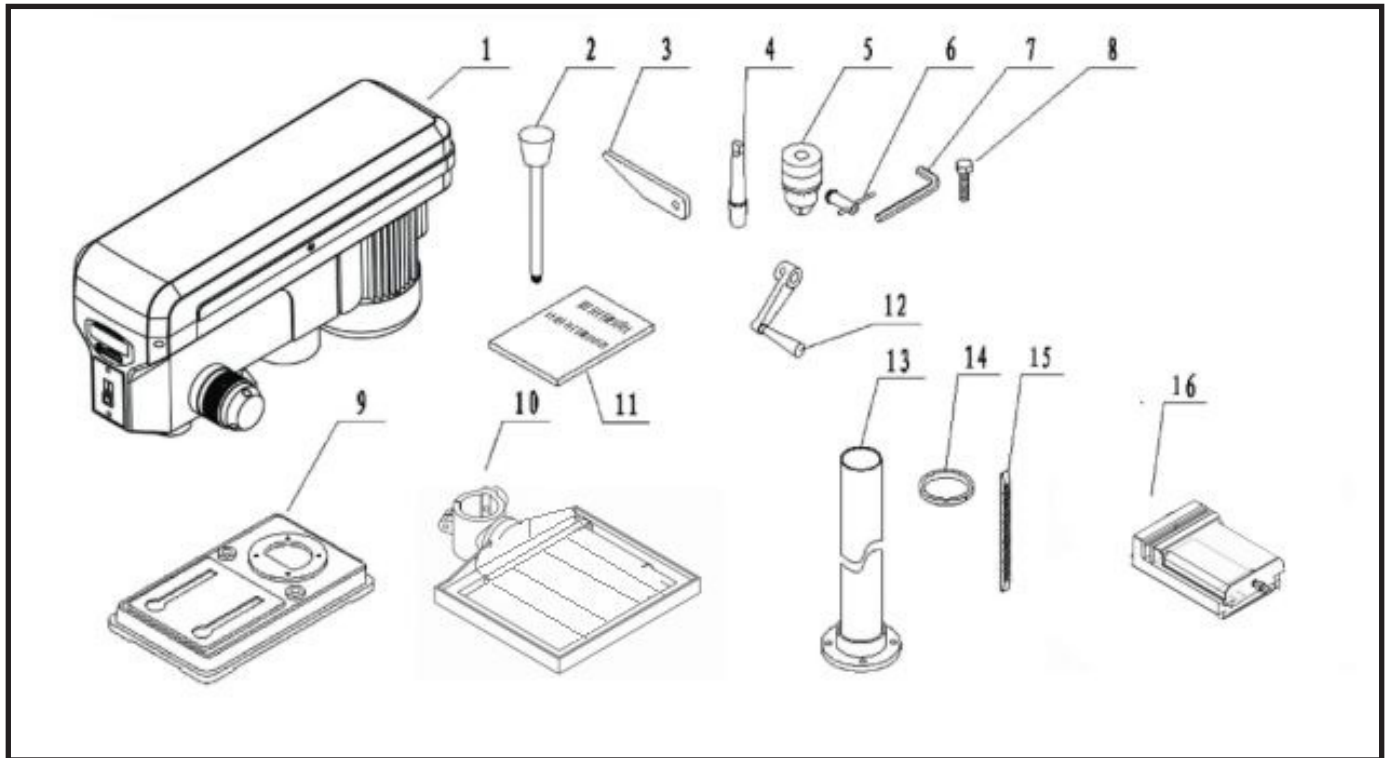

CONTENTS

Ref.	Qty.	Description	Ref.	Qty.	Description
1	1	Head Assembly	9	1	Base Platform
2	3	Feed Handles	10	1	Table
3	1	Chuck Wedge	11	1	Manual
4	1	Arbor	12	2	Lifting/Vise Crank
5	1	Chuck	13	1	Column Assembly
6	1	Chuck Key	14	1	Column Collar
7	1	Hex Key	15	1	Rack
8	4	Hex Bolts	16	1	Vise

Floor Standing Drill Press

1. Place the Base Platform (9) on the bench top and attach the Column Assembly (13) using four hex bolts.
2. Place the rack into the Table (10) and attach to the Column Assembly. Install the Column Collar (14) above the lifting rack using the set screw it came with.
3. Attach Cranks (12) to table support and vise. Secure with set screws.

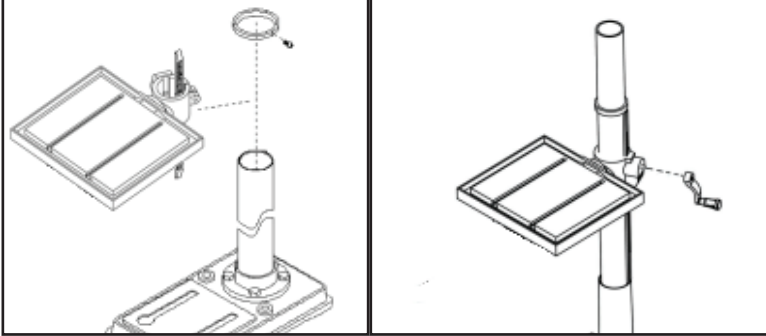
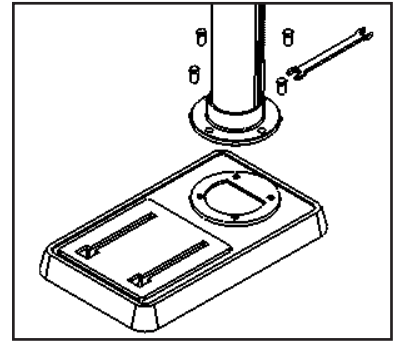

4. Set the Table to desired height then tighten the table support clamp handle to lock the table support in place.

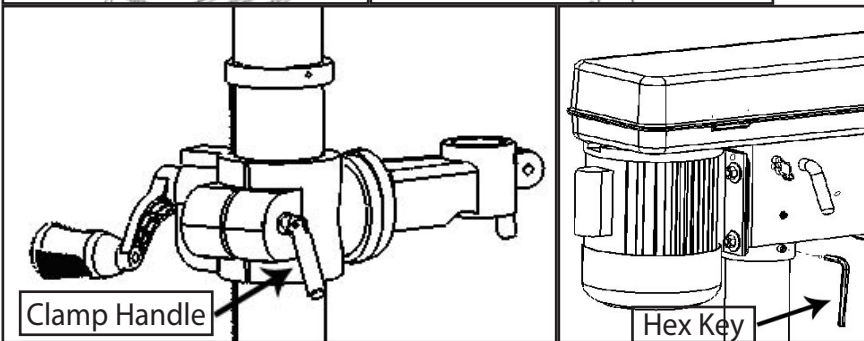

5. Lift the Head Assembly (1) on top of the column and slide it down as far as it will go. Align the Head Assembly with the Base Platform (9). Tighten the set screw to secure the head.
6. Attach the Feed Handles (9) to the feed crank hub and secure the hub to the Head Assembly (1).
7. Rotate the chuck sleeve clockwise open the jaws of the chuck. Make sure the chuck jaws are fully opened and receded into the chuck.
8. Push the chuck into the spindle. Using a wooden or rubber mallet, tap the chuck up to secure it onto the spindle shaft.

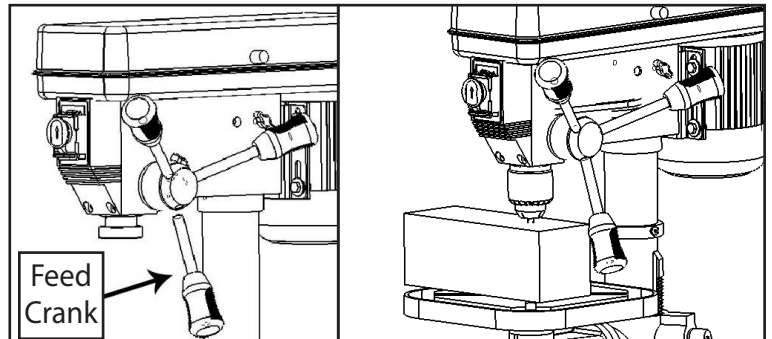

⚠ WARNING

Product is shipped with protective oil coating on metal surfaces. Mating surfaces of spindle and chuck **MUST** be cleaned before assembly to prevent parts from coming loose during operation.

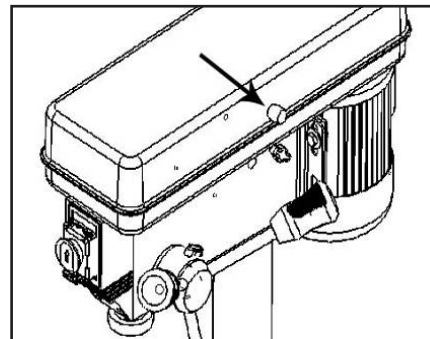

9. Secure upper pulley cover of head assembly by installing locking knob.

Floor Standing Drill Press

OPERATION

Properly adjust Drill Press components before drilling

1. Set the table to preferred height by undoing the table clamp bolt and turning the lifting crank. Tighten clamp bolt once desired height has been reached.
2. To rotate the table, loosen the table clamp bolt and rotate the table to the desired position. Tighten the clamp bolt when position is achieved.
3. Set table angle by loosening table lock bolt and adjusting table to desired angle. When desired angle is achieved, secure lock bolt.
4. Drill feed depth can be adjusted. To adjust feed depth, loosen feed locking screw and rotate scale to desired height, then tighten locking screw. Adjust the scale to drill different holes to equal depths.
5. The spindle can be locked at different heights. Set the spindle to the desired height using the feed crank, then tighten the feed crank set screw. This feature is useful for aligning workpiece.
6. Speed can be adjusted by changing belt location. Open the belt box in the Head Assembly, loosen the belt tensioning lock knob, pull the motor mounting plate to the front and then move the belt to the desired pulleys. Refer to Spindle Speed Table for pulley speeds. When Belt is mounted, push motor mounting plate back to rear and lock the belt tensioning knob. NOTE: Drill speed is determined based on workpiece material and drill bit type and thickness. Consult drill speed chart to determine required speed (next page).

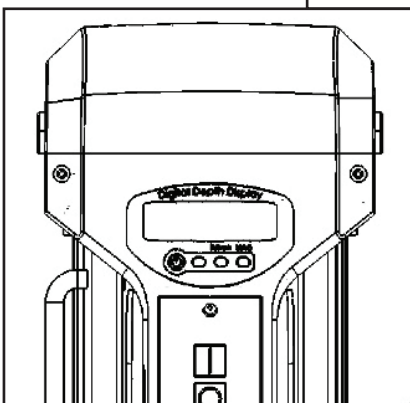
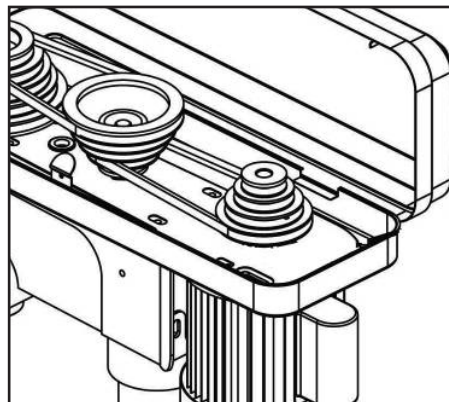
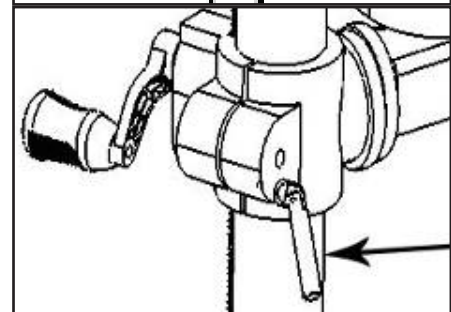
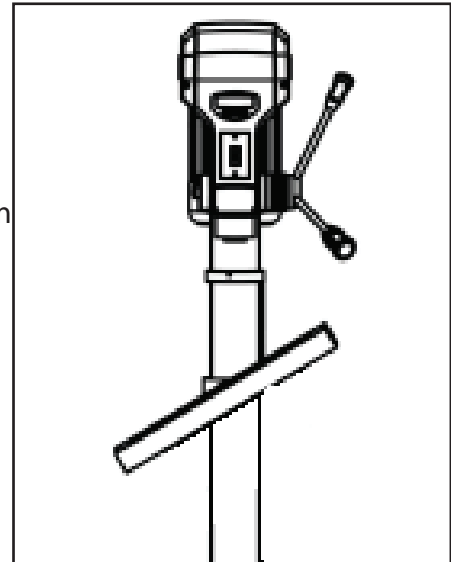

NOTE: Feed depth can also be read from digital display

Floor Standing Drill Press

DRILL BIT TYPES

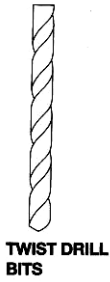

TWIST DRILL BITS



BRAD-POINT BITS

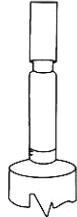

FORSTNER BITS

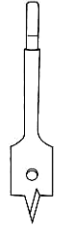

SPADE BITS

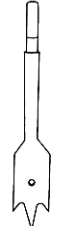

SPADE BITS (W/SPURS)

⚠ WARNING

Ensure Drill Press is turned OFF and power cord is disconnected before opening belt box and adjusting drill speed.

NOTE: Drill bits are not included with drill press

Recommended Operating Speeds (in RPMS)

	Material					
	SOFTWOOD	HARDWOOD	ACRYLIC	BRASS	ALUMINUM	STEEL
TWIST DRILL BITS						
1/16-3/16" (3-5mm)	3000	3000	2500	3000	3000	3000
1/4-3/8" (6-10mm)	3000	1500	2000	1200	2500	1000
7/16-5/8" (11-16mm)	1500	750	1500	750	1500	600
11/16-1" (11-25mm)	750	500	NR	400	1000	250
BRAD-POINT BITS						
1/8"	1800	1200	1500	NR	NR	NR
1/4"	1800	1000	1500	NR	NR	NR
3/8"	1800	750	1500	NR	NR	NR
1/2"	1800	750	1000	NR	NR	NR
5/8"	1800	500	750	NR	NR	NR
3/4"	1400	250	750	NR	NR	NR
7/8"	1200	250	500	NR	NR	NR
1"	1000	250	200	NR	NR	NR
FORSTNER BITS						
1/4-3/8"	2400	700	250	NR	NR	NR
1/2-5/8"	2400	500	250	NR	NR	NR
3/4-1"	1500	500	250	NR	NR	NR
1 1/8-1 1/4"	1000	250	250	NR	NR	NR
1 3/8-2"	500	250	NR	NR	NR	NR
SPADE BITS						
1/4-1/2"	2000	1500	NR	NR	NR	NR
5/8-1 1/2"	1750	1500	NR	NR	NR	NR
1 1/8-1 1/2"	1500	1000	NR	NR	NR	NR
SPADE BITS WITH SPURS						
3/8-1 NR	2000	1800	500	NR	NR	NR

NR-Not Recommended

Floor Standing Drill Press

7. Adjust quill spring if return speed is too fast or too slow. Lower table for additional clearance if necessary. See figure for components.
 - a. Hold spring cap (2) in place by jamming a flat head screwdriver in lower front notch (1), then remove outer jam nut (3).
 - b. Loosen inner jam nut (4) until spring cap notch (5) disengages boss (6). **DO NOT REMOVE INNER JAM NUT**, quill spring will forcibly unwind.
 - c. Using the screwdriver, rotate the spring cap counterclockwise until the next notch engages the boss.
 - d. While holding the spring cap in place, rotate the feed crank to lower the quill to its bottom position.
 - e. Tighten inner jam nut to check quill spring tension.
 - f. If quill spring tension is still too loose, repeat steps b through e. If quill spring tension is too tight, turn spring cap clockwise until next notch engages and tighten inner jam nut. **DO NOT OVERTIGHTEN INNER JAM NUT**, you will restrict quill movement.
 - g. When desired tension is achieved, tighten outer jam nut to secure inner jam nut.

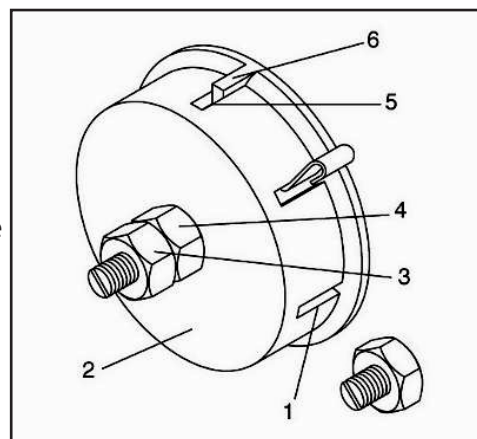

DRILLING INSTRUCTIONS

8. With power switch OFF, install drill bit by opening the drill chuck. To open the chuck, insert the chuck key and turn counterclockwise. Insert drill bit as deeply as possible without the chuck biting the drill grooves. Tighten chuck jaws to secure drill bit and remove chuck key. **DO NOT TURN ON DRILL PRESS WITH CHUCK KEY STILL IN CHUCK, CHUCK KEY MAY BE FORCIBLY EJECTED AND CAUSE PERSONEL INJURY OR PROPERTY DAMAGE.**
9. Brace workpiece against LEFT side of column or secure workpiece to table with clamps or vise grips. Failure to do so may result in personel injury. **ALWAYS CLAMP SHARP WORKPIECES SUCH AS SHEET METAL SECURELY AT MULTIPLE POINTS TO TABLE. NEVER DRILL SHARP OBJECT FREEHAND.**
10. For small worpieces that can not be safely held or clamped to table, use a drill press vise. Make sure vise is securely bolted to table, **DO NOT BEGIN DRILLING IF VISE IS NOT PROPERLY SECURED TO TABLE.**

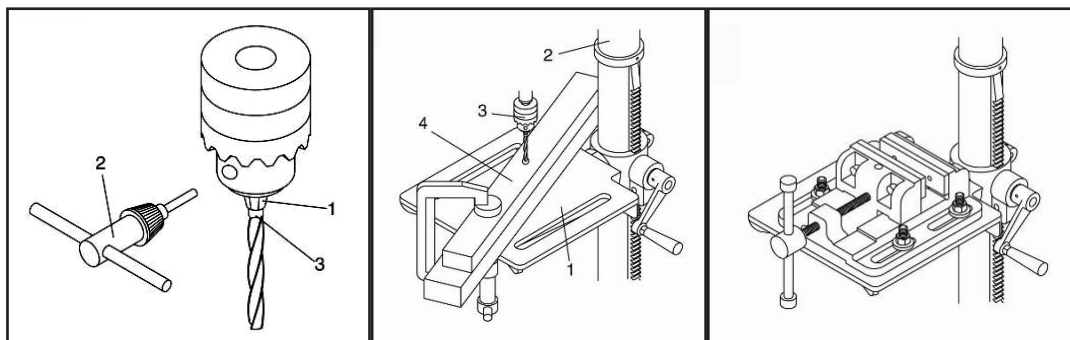

MAINTENANCE

⚠ WARNING

Before performing any inspection, cleaning, or maintenance procedures, make sure the machine's power switch is in the "OFF" position and that the power cord is unplugged.

Dust and chips from workpieces may accumulate on drill press components. Use compressed air or a shop vacuum to remove any that may accumulate in the motor and belt box.

Lower spindle to maximum depth and apply small coat of oil every 3 months.

Exposed metal surfaces such as the table and column are coated with wax at the factory to prevent rust.

Ball bearings and rotating components come greased from the factory and should not require any maintenance.

Floor Standing Drill Press

TROUBLE SHOOTING

Problem	Possible Cause	Corrective Action
Noisey Operation	Incorrect belt tension Loose Motor Pulley Loose Spindle Dry Spindle	Adjust belt tension lock knob Tighten motor pulley set screw Tighten spindle pulley nut Lubricate spindle
Drill bit smokes	Speed is too high Chips bunching up in hole Drill bit is dull	Reduce speed Drill with "pecking" motion, retract bit more frequently to clear chips Sharpen or replace bit
Drill bit runs out or wobbles	Drill bit is bent Drill bit is improperly installed Drill chuck is improperly installed Spindle bearings are worn	Replace bit Reinstall bit properly Reinstall chuck properly Replace spindle bearings
Drill bit binds in workpiece	Excessive feed pressure Incorrect belt tension	Decrease feed pressure Adjust belt tension lock knob
Workpiece comes loose and spins with drill bit	Improperly supported or clamped	Brace workpiece against left side of column or tighten clamps