



User Manual

Model: C3236

Checkweigher

Table of Contents

1. General information and Warnings page 5

FCC Declaration of Compliance - <i>Déclaration de conformité</i>	5
Training - <i>Formation</i>	6
Battery Safe Disposal - <i>Élimination sécurisée des batteries</i>	6
Routine Maintenance - <i>Entretien de routine</i>	6
Cleaning the Machine - <i>Nettoyage de la machine</i>	6
Sharp Objects - <i>Objets tranchants</i>	6

2. Introduction page 7

Unpacking.....	7
General Installation Guidelines.....	7
Levelling the Scale.....	7
Battery Operation.....	7
Front Panel.....	8
Display Annunciators.....	8
Operation Keys.....	9
Error Codes.....	9

3. Scale Operation page 10

Gross Weighing.....	10
Tare Weighing.....	10
Clear a Tare.....	10
Checkweighing.....	10
Setting the Checkweighing Limits.....	11
Checkweighing Beeper Modes.....	11
Changing Units of Measure.....	11

4. Menus **page 12**

User Menu.....	12
User Menu Levels.....	12
User Functions Descriptions [UF].....	12
Supervisor Menu.....	13
Supervisor Menu Levels.....	13
Supervisor Functions Descriptions [LF].....	14
Quick Calibration Menu.....	15
Quick Calibration Menu Levels.....	15
Quick Calibration Functions Descriptions [ECF].....	15

5. Scale Configuration [LF 2] **page 16**

6. Calibration **page 17**

Scale Calibration Procedure.....	17
----------------------------------	----

7. Replacement Parts **page 18**

Manual revision history

Current Issue	Date Created	Details of Changes
Draft	Jan. 2019	New

1. General Information and Warnings

1.1. FCC Declarations of Compliance - FCC Déclaration de conformité

United States

This equipment has been tested and found to comply with the limits for a Class A digital device, pursuant to Part 15 of the FCC Rules. These limits are designed to provide reasonable protection against harmful interference when the equipment is operated in a commercial environment. This equipment generates, uses, and can radiate radio frequency energy and, if not installed and used in accordance with the instruction manual, may cause harmful interference to radio communications. Operation of this equipment in a residential area is likely to cause harmful interference in which case the user will be required to correct the interference at his own expense.

Canada

This digital apparatus does not exceed the Class A limits for radio noise emissions from digital apparatus set out in the Radio Interference Regulations of the Canadian Department of Communications.

Le présent appareil numérique n'émet pas de bruits radioélectriques dépassant les limites applicables aux appareils numériques de la Classe A prescrites dans le Règlement sur le brouillage radioélectrique édicté par le ministère des Communications du Canada. Interference Regulations of the Canadian Department of Communications.

1.4. Training - Formation

Do not attempt to operate or complete any procedure on a machine unless you have received the appropriate training or read the instruction books.

Ne pas tenter d'utiliser la machine ou lui appliquer une quelconque procédure sans avoir reçu une formation adaptée ou lu les manuels d'instruction.



CAUTION! Risk of electrical shock. Refer to qualified service personnel for service.

ATTENTION! *Risque de choc électrique. Confier la réparation de l'appareil à un personnel qualifié.*

1.5. Safe Battery Disposal - Élimination sécurisée des batteries

Please be aware this product contains a lead acid battery which MUST be removed and disposed of safely prior to any disposal of the scale.

The battery can be accessed by removing the battery cover found on the underside of the scale.



CAUTION! Danger of explosion if battery is incorrectly replaced. Replace only with the same or equivalent type recommended by the manufacturer.

ATTENTION! *Il y a danger d'explosion s'il y a remplacement incorrect de la batterie, remplacer uniquement avec une batterie du même type ou d'un type équivalent recommandé par le constructeur.*

1.6. Routine Maintenance - Entretien de routine

IMPORTANT: This equipment must be routinely checked for proper operation and calibration. Application and usage will determine the frequency of calibration required for safe operation.

PRUDENCE: Le fonctionnement et l'étalonnage de cet équipement doivent être vérifiés régulièrement. Les applications et l'utilisation déterminent la fréquence de l'étalonnage requis pour une utilisation en toute sécurité.

1.7. Cleaning of Scale - Nettoyage de la machine

Do - Ce qu'il faut faire	Do NOT - Ce qu'il ne faut pas faire
Wipe down the outside of product with a clean cloth, moistened with water and a small amount of mild detergent cleaning fluid. <i>Essuyer la partie externe des produits standard à l'aide d'un chiffon propre légèrement imprégné d'eau et d'une petite quantité de détergent doux.</i>	Use harsh abrasives, solvents, scouring cleaners or alkaline cleaning solutions. <i>Utiliser des produits abrasifs, des solvants, des produits de récurage ou des solutions de nettoyage alcalines.</i>
Spray on to the cloth when cleaning and not directly onto the indicator area. <i>Pulvériser tout produit de nettoyage spécifique sur le chiffon.</i>	Do not attempt to clean the inside of the machine. <i>Tenter de nettoyer l'intérieur de la machine.</i>
	Spray any liquid directly on to the display windows. <i>Pulvériser des liquides directement sur les écrans d'affichage.</i>

1.8. Sharp Objects - Objets tranchants

Do not use any sharp objects such as screwdrivers or long fingernails to operate the keys.

Ne pas appuyer sur les touches avec des objets tranchants tels que des tournevis ou même des ongles longs.

2. Introduction

The C3236 is a high resolution stainless steel IP68 wash-down scale ideal for general food weighing, portion control or checkweighing applications. This scale offers a fast weight indication along with an easy to use Under, Over and Acceptable weight indication. Ideal for most food processing environments or where weighing needs to take place in a clean wet environment.

This manual covers the introduction to the unit, its use, configuration and calibration.

2.1 Unpacking

Carefully take the scale out of its package, make it sure it's not damaged and all accessories are included.

- Remove the scale from the carton
- Remove the protective covering
- Inspect the scale and terminal for damage
- Make sure all components are included:
 1. C3236 Scale
 2. Adaptor plus plug adaptors
 3. Weight Platter

2.2. General Installation Guidelines

To get the best performance from the scale try to place the C3236 in a location that will not degrade its accuracy.

- Avoid extremes of temperature. Try to avoid placing the scale in direct sunlight or near air vents.
- Place the scale on a level flat surface. Do not place the scale near vibrating machinery
- Avoid unstable power sources. Do not use near large users of electricity, e.g. welding equipment.

2.3. Levelling the Scale

Level bubble is located at the front left corner of the display.

- Place the scale on a level flat surface.
- The level bubble should be centered inside the inner ring.
- If the scale is not level, adjust the levelling feet until the level bubble is centered correctly.

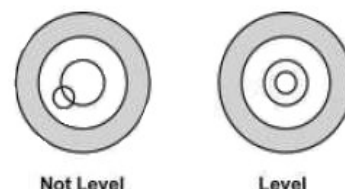

! *Always check the level prior to using scale.*

2.4. Battery Operation

To charge the 6V 4Ahr battery, plug in the supplied power adaptor into an AC power outlet and attach the DC wash-down connector end to the scale (Fig. 1). The scales DC water proof connector can be found under the scale near the battery compartment, slide back the bottom battery cover and pull out the DC charging lead with water proof connector and attach it to the supplied power adaptor.

This water proof connector has a key that has to be lined up so it can only be plugged in in one direction. Close the battery lid making sure the lead is not trapped and turn on the scale

Please note the scale does not need to be turned on to charge the battery. The battery should be charged for at least **6hrs** to fully charge the battery.

When the scale is turned on, the battery annunciators are:

- **LOW BATTERY**, battery needs to be recharged;
- **CHARGE**, battery is being charged (6hrs).

Do not use any other type of power adaptor than the one supplied with the scale and verify that the AC power socket outlet is properly protected.



Charge the battery before using (+6hrs).



Caution! When cleaning or washing down the scale, please insure the power adaptor is fully removed from the scale prior to cleaning.



Figure 1 - C3236 underside view.

2.5. Front Panel

Figure 2 shows the front panel of the unit. It includes the display window, the annunciators arrayed around the display, the four keys, and the bubble level.

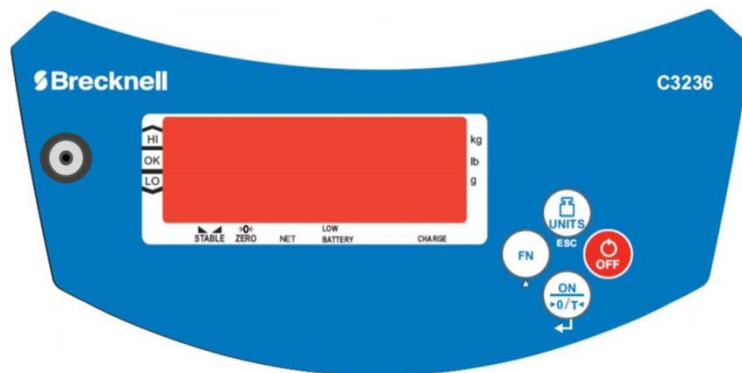

Figure 2 - C3236 front panel.

2.5.1. Display Annunciators

HI	Over acceptable weight range
OK	Within acceptable weight range
LO	Under acceptable weight range
→0← ZERO	Scale at Zero
▲ STABLE	Display reading is stable
NET	Indicates a Net weight
LOW BATTERY	Battery needs to be recharged
CHARGE	Battery is being charged (6hrs).
kg lb g	Current unit of measure

2.5.2. Operation Keys

Keys are shown below along with their functions. Some keys have secondary functions.



- Press the **UNITS** key to scroll through the active units of measure.
- **In Menu mode**: It aborts a numeric entry and acts as an ESCAPE key for menu navigation (esc).



Press and hold the **OFF** key to turn off the scale. **oFF** will be displayed for 2 seconds.



- Press the **ON** key to turn on the scale. The scale will self-adjust to **0**.
- Press this key to **Zero** the display.
- Press this key to **Tare** the weight on the scale up to 100% of capacity.
- **In Menu mode**: It accepts the displayed item/value in the menu structure or during numeric entry (↵).



- Use the **FN** key to access and navigate the menus and options.
- **In Menu mode**: It increments a numeric value (▲).

2.6. Error Codes

Err H	Initial zero too high (over FULL SCALE + 10%), for approved models [LF 6]
Err L	Initial zero too low (under FULL SCALE – 10%), for approved models [LF 6]
Err N	Unstable internal count, this may indicate the load cell or electronics are faulty
-OL-	Overload, full capacity +9d

3. Scale Operation

The steps for various kinds of weighing are explained in the following pages. To set parameters and calibrate the unit, see chapters 4.3. Supervisor Menu on page 13 and 6. Calibration on page 17.

ⓘ **A warm-up time of 15 minutes is required to stabilize the measured values.**

3.1. Gross Weighing

To perform a gross weightment, follow these steps:

1. Power up the scale. Be sure the scale is displaying weight in the correct unit of measure. Press the **UNITS** key, if necessary.
2. Zero the scale if necessary by pressing the **ON/ZERO/TARE** key. **0.000** is displayed.
3. Place the item(s) on the scale platform.
4. Remove the item(s) and repeat steps 2 through 4 for the next item(s).

3.2. Tare Weighing

If you want to do NET weighing, such as weighing objects in a container, follow these steps:

1. Power up the scale. Be sure the scale is displaying weight in the correct unit of measure. Press the **UNITS** key, if necessary.
2. Zero the scale if necessary by pressing the **ON/ZERO/TARE** key. If the weight change is within the Zero window area the display will show **0.000**.
3. Place the empty container to be tared on the scale platform.
4. Press the **ON/ZERO/TARE** key. If the container weight is outside the Zero window area the display will show **0.000** weight and the NET annunciator is illuminated.
5. Place the item to be weighed into the empty container and place on the scale platform. Net weight of the item is displayed.
6. Remove the item and repeat steps 2 through 5 for other items.

3.2.1. Clear a Tare

Remove any load from the scale and press the **ON/ZERO/TARE** key until **0.000** is displayed. The **NET** annunciator will turn off.

3.3. Checkweighing

Checkweighing is a function that allows you to enter an upper and lower acceptable weight for a product or item that must be checked for weight conformity.

To set the limits and beeper modes, see sections 3.3.1. and 3.3.2.

To perform a gross weightment, follow these steps:

1. Power up the scale. Be sure the scale is displaying weight in the correct unit of measure. Press the **UNITS** key, if necessary.
2. Zero the scale if necessary by pressing the **ON/ZERO/TARE** key. **0.000** is displayed.
3. Place the item to be checkweighed on the scale platform. The weight is displayed and the **LO**, **OK** or **HI** annunciator illuminates (Fig.3).
4. Remove item from the scale platform and repeat steps 3 and 4 for each item to be checkweighed.



Figure 3 - C3236 limits annunciators: LO, OK, HI.

ⓘ **Checkweighing limits use the unit of measure the limits were set in.**

3.3.1. Setting the Checkweighing Limits

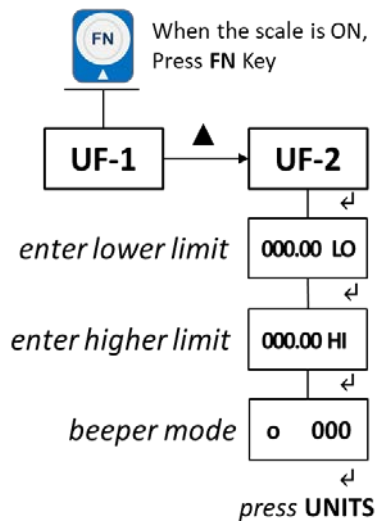

- i. When the scale is ON, press **FN** (▲) key;
UF-1 will be displayed.
- ii. Press **FN** (▲) key;
UF-2 will be displayed.
- iii. Press **ON/ZERO/TARE** (↵) key;
- iv. To enter or edit the **LO** limit value, scroll through the displayed digits by using the **ON/ZERO/TARE** (↵) key. Press the **FN** (▲) key to increase the value of the flashing digit.
- v. Press **ON/ZERO/TARE** (↵) key to confirm;
- vi. Repeat points *iv.* and *v.* for the **HI** limit;
- vii. Choose the **beeper mode** [000; 001; 002] navigating the decimal position by pressing **ON/ZERO/TARE** (↵) key. Press the **FN** (▲) key to increase the value of the flashing digit.
- viii. Press **ON/ZERO/TARE** (↵) key to complete and leave the procedure;
- ix. Press **UNITS** (ESC) key to exit the User Menu.

ⓘ **To disable the checkweighing feature, set the Hi and Lo limits to 0 in the User Menu [UF-2].**
The LO and HI annunciators will be turned off.

3.3.2. Checkweighing Beeper Modes

There are three modes.

- | | |
|--------------|---|
| o 000 | The beeper is disabled. |
| o 001 | The beeper sounds only when the load is <u>within</u> the acceptable limits. |
| o 002 | The beeper sounds only when the load is <u>outside</u> the acceptable limits. |

ⓘ **Please, ignore any other mode not listed above.**

3.4. Changing Units of Measure

1. With the scale turned on press the **UNITS** key to select the required unit of measure you want the scale to work in from kg – grams –lb.

4. Menus

There are three menus that allow to configure, enable or execute specific functions or options.

- | | |
|--|------------|
| • User Menu <i>UF – 1 ~ 11</i> | page
12 |
| • Supervisor Menu <i>LF 1 ~ 8</i> | 13 |
| • Quick Calibration Menu <i>ECF – 1 ~ 3</i> | 15 |

4.1. User Menu

In the User Menu there are various submenus available to configure specific sections of the scale operating modes, including a diagnostic feature.

4.1.1. User Menu Levels [UF]

Navigate the menus and increase a numeric value by pressing **FN** (\blacktriangle) key. Use **ON/ZERO/TARE** (\leftarrow) key to confirm and/or move to the next option or numeric value position. Press **UNITS** (esc) key to exit the option or the menu.

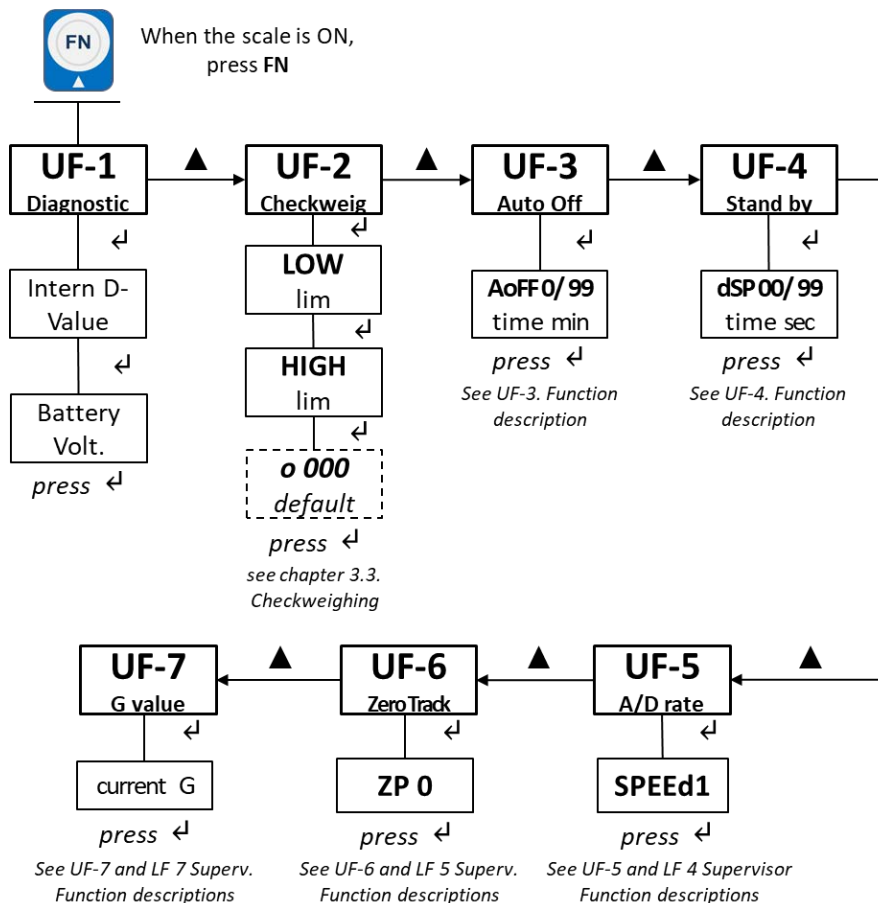

4.1.2. User Functions Descriptions [UF]

There are 11 Setup Functions.

- | | |
|-------------|--|
| UF-1 | Diagnostic: use this menu to check or verify the performance of the indicator. The diagnostic tests are: <i>Internal A/D Value</i> and <i>Battery Voltage</i> . |
| UF-2 | Checkweighing: the acceptable weight is any weight which falls between the upper and lower limits. Enter this option to set the items relating to Checkweighing: <ul style="list-style-type: none"> • <i>LOW / HIGH</i> limits. Valid beeper modes: <i>o 000</i>; <i>o 001</i>; <i>o 002</i>. See chapter 3.3. on page 10. |

UF-3	Auto Power-Off: use this to set the length of time before the scale automatically turns off if not being used. Values can be set between 01 and 99 minutes. <i>Factory default: AoFF 10 (10min). Auto Power-OFF disabled when AoFF 00</i>
UF-4	Stand by: a battery power saving function to turn off the display power but not turn off the scale. Ideal for weight processes where the scale could stay inactive for long periods of time and where the Zero point or current weight cannot be lost. Any weight change or key press will automatically turn the display back on. Values between 01 and 99 seconds are valid.
UF-5	ADC Update Rate: use this to select the sampling frequency: 15 (1), 30 (2) or 7.5Hz (3) See Supervisor Menu.
UF-6	Automatic Zero Tracking: use this to define a $\pm 0/5$ divisions range around zero. See Supervisor Menu.
UF-7	Gravitational value: use this item to key in a G constant value: $9.78031 < G < 9.83217$ See Supervisor Menu.

4.2. Supervisor Menu

In the Supervisor Menu there are various submenus available to configure system parameters, specific sections of the operating modes and the calibration feature (see also chapter 6. Calibration).

4.2.1. Service Menu Levels [LF]

Navigate the menus and increase a numeric value by pressing **FN** (\blacktriangle) key. Use **ON/ZERO/TARE** (\leftarrow) key to confirm and/or move to the next option or numeric value position. Press **UNITS** (esc) key to exit the option or the menu.

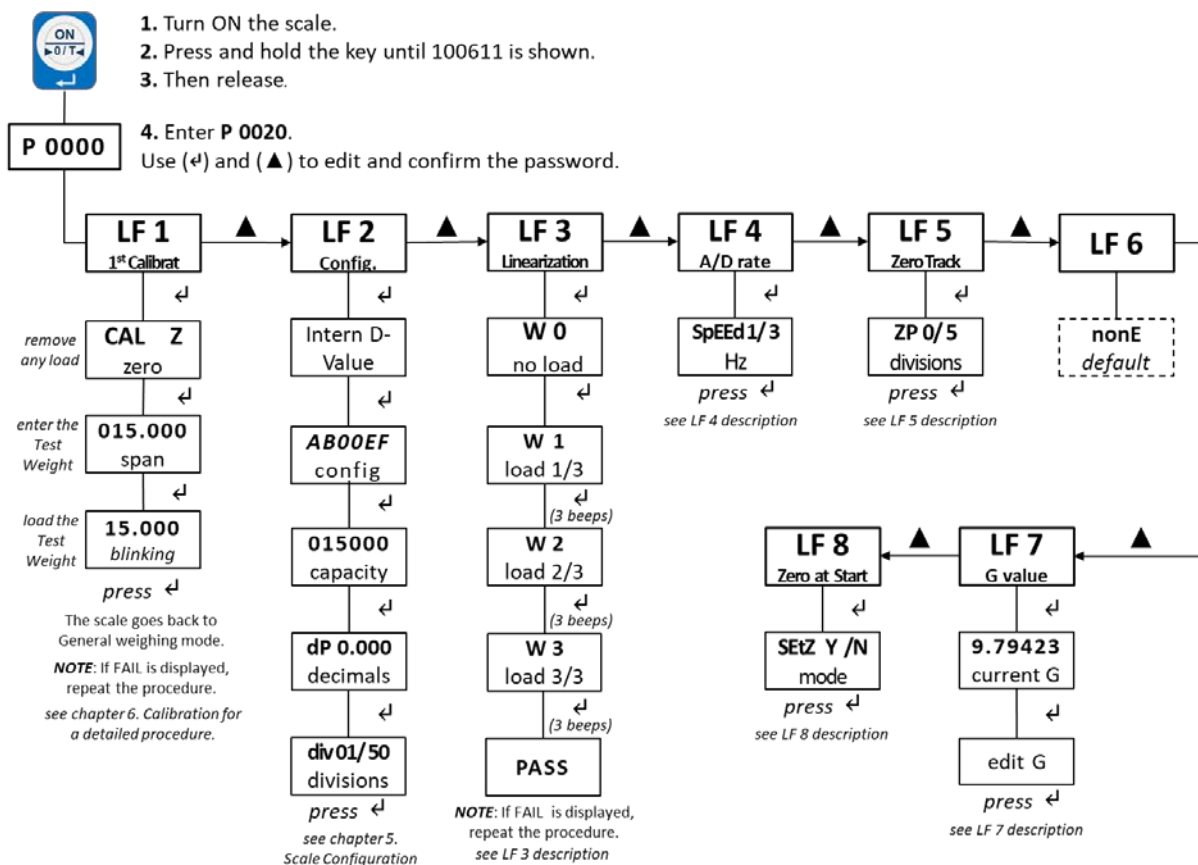

4.2.2. Supervisor Functions Descriptions [LF]

There are 8 functions.

LF 1	1st Calibration: see chapter 6. Calibration on page 17 for a detailed procedure.
LF 2	Configuration: use this item to configure system parameters, specific sections of the operating modes. See chapter 5. Scale Configuration at page 16.
LF 3	Linearization: use this to add 1-3 linearization points for the scale equivalent to 0, 1/3, 2/3 and 3/3 of the max capacity.  CAUTION! Perform the linearity procedure only if test weights applied to the scale between the zero and span calibration points are showing slight inaccuracies, such as \pm a few divisions. If large inaccuracies are recorded, this indicates a possible mechanical problem or possible load cell failure which linearity calibration may not be able to correct.
LF 4	ADC Update Rate: use this to select the sampling frequency: 15 (1), 30 (2) or 7.5Hz (3) <i>Factory default: SPEEd 1 (standard 15Hz)</i>
LF 5	Zero Tracking: use this to define a $\pm 0 /5$ divisions range around zero. When scale weight is not at the center of zero but inside this range, $\frac{1}{2}$ of the weight will be subtracted until that the weight is inside the center of zero region. <i>Factory default: ZP 0 (off)</i>
LF 6	Factory default: none
LF 7	Gravitational value: use this item to key in a G constant value: $9.78031 < G < 9.83217$ If the scale has been calibrated at a different location and it is not possible to re-calibrate with known test weights, the scale can be adjusted using this gravity factor. <i>Factory default: 9.81259</i>
LF 8	Zeroing at Every Power UP: use this items to set an auto zero at the power up. <i>Factory default: SEtZ Y (on)</i>

4.3. Quick Calibration Menu

See chapter 6. Calibration on page 17 for a detailed procedure.

NOTE: Default calibration units are in kg. To change this to lb please refer to Scale configuration LF 2 on page 16.

4.3.1. Quick Calibration Menu Levels [ECF]

Navigate the menus and increase a numeric value by pressing **FN** (**▲**) key. Use **ON/ZERO/TARE** (**↵**) key to confirm and/or move to the next option or numeric value position. Press **UNIT** (**esc**) key to exit the option or the menu.

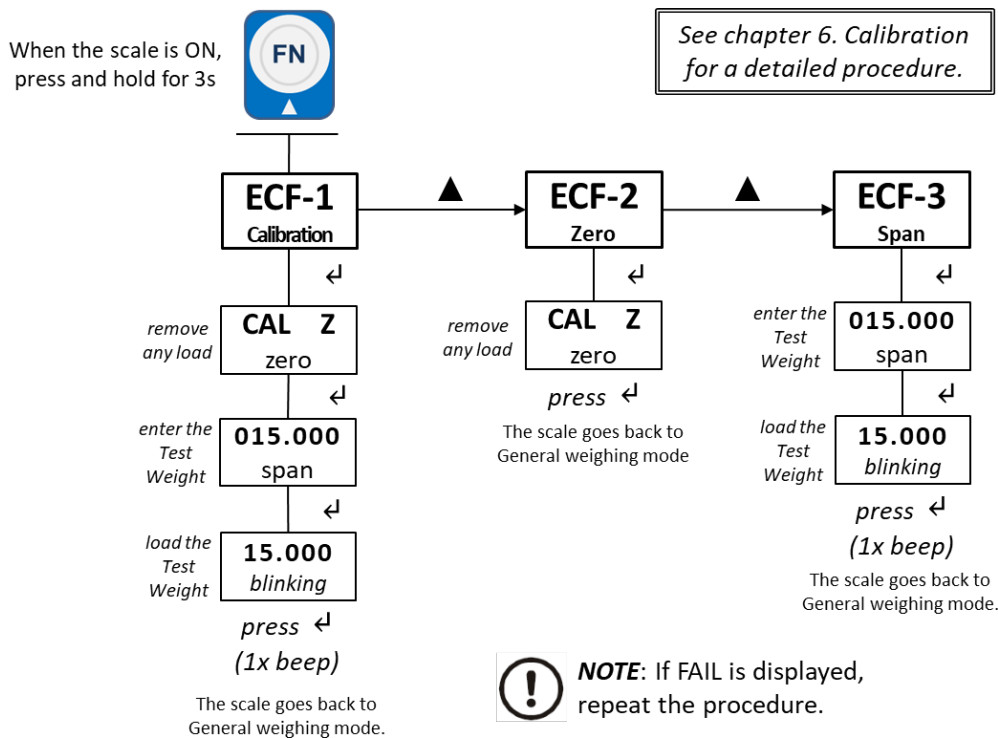

4.4.2. Quick Calibration Functions Descriptions [ECF]

There are 3 Calibration Functions.

ECF-1	Calibration: ZERO / SPAN. Test weight should be at least 1/3 of the max. capacity
ECF-2	Zero Calibration (only)
ECF-3	Span Calibration (only)

5. Scale Configuration [LF 2]

Enter the function LF 2 to set the units, range mode, calibration units, decimal position of the separator and division size.

Navigate the menus and increase a numeric value by pressing **FN** (**▲**) key. Use **ON/ZERO/TARE** (**↵**) key to confirm and/or move to the next option or numeric value position. Press **UNIT** (**esc**) key to exit the option or the menu.



1. Turn ON the scale.
2. Press and hold the key until 100611 is shown.
3. Then release.

P 0000

4. Enter P 0020.
Use (**↵**) and (**▲**) to edit and confirm the password.

LF 1
1st Calibrat

LF 2
Config.

Intern D-
Value

AB000F
config

015000
capacity

dP 0.000
decimals

div01/50
divisions

press ↵

DESCRIPTION	OPTIONS
A Metric Units	0= none; 1= kg; 2= n/a; 3= g
B Imperial Units	0= none; 1= lb;
0 Do NOT use	
0 Do NOT use	
0 Do NOT use	
F Cal. Units	1= Metric; 2= Imperial

Default. Scale units: **kg** and **lb**. Calibration unit set as **kg**.

1 1 0 0 0 1

Example 1. Scale units: **kg** and **lb**. Calibration unit set as **lb**.

1 1 0 0 0 2

6. Calibration

It is recommended to perform only the very first calibration following the function **LF 1** in the **Supervisor Menu**. To prevent any unintentional change of the scale configuration, all the subsequent Calibrations should be performed entering the **Quick Calibration Menu [ECF]**.

Both procedures above, must be conducted following the steps on the **6.1 Scale Calibration Procedure**.

6.1. Scale Calibration Procedure

The following procedures assume that the scale has been already properly configured [function **LF 2**], including the settings of the **Gravitational** correction values [function **LF 7**] and **Linearity** correction points [function **LF 3**].



Perform the linearity procedure only if test weights applied to the scale between the zero and span calibration points are showing slight inaccuracies, such as \pm a few divisions. If large inaccuracies are recorded, this indicates a possible mechanical problem or possible loadcell failure which linearity calibration may not be able to correct.

LF-2 CALIBRATION SETTINGS

- Default setting is for calibrating in **kg** [110001]
- To calibrate in **lb** set LF2 to [110002]

The calibration steps following the function LF 1 or entering the Calibrations Menu ECF are the same. For this reason only the ECF is described below.

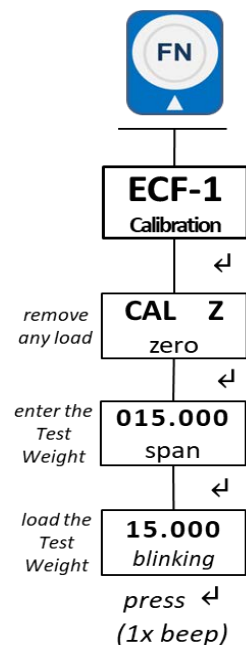

Before starting, make sure that LF 3 and LF 7 are configured as desired and test weight equivalent to at least 1/3 of the maximum capacity.

- When the scale is ON, press and hold the **FN(▲)** key for 3 seconds;
ECF-1 will be displayed.
- Press **ON/ZERO/TARE (↵)** key;
CAL Z will be displayed.
- Remove the loads from the pan and press **ON/ZERO/TARE (↵)** key;
- Edit the span increasing the numeric value by pressing **FN(▲)** key and/or press **ON/ZERO/TARE (↵)** key to move to the next digit;
- Press **ON/ZERO/TARE (↵)** key to confirm;
- When the span value blinks, load the test weight;
- Press **(ON/ZERO/TARE (↵))** key to complete and exit the procedure.

7. Replacement Parts

Part number	Description
AWT25-502472	Power supply universal with USA-UK & EU plug adaptors (100 to 240VAC 50/60 Hz output: 12V 1000mA with special water proof 2 pin connector)
	Replacement battery (DJW6-4.0 6V4.0AH lead acid battery)
AWT20-509288	Replacement feet Kit (4 feet and lock nuts)