

Instruction Manual	Manual de Instrucciones	Manuel d'instruction
Customer Service US: 1-800-645-2986	Servicio de atención al Cliente México: 01.800.681.6940	Service à la clientèle Canada: 888-645-2986

Crawl Space Commercial Dehumidifier with Pump

Model 246707

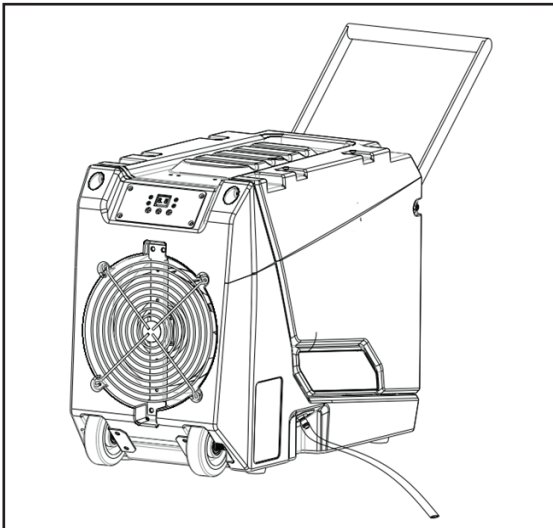

⚠ WARNING: Follow these safety precautions prior to assembly and operation.

- To protect against electric shock, do NOT immerse cord, plug, or any other part of the machine in water or other liquids.
- Do not put the machine close to heat-generating devices, including flammable or dangerous materials.
- Do not put fingers or other items into air inlet or air outlet.
- Do not sit, stand or put heavy objects on the machine.
- Never operate the machine when the power cord or plug is damaged. If damaged, contact Global Industrial or a qualified service technician.
- This appliance should only be used by adults who have read the manual and understand the operating procedure of the unit.
- The appliance is not to be used by persons (including children) with reduced physical, sensory or mental capabilities, or lack of experience and knowledge, unless they have been given supervision or instruction by an adult.
- Install the machine on a flat surface to minimize vibration and/or noise.
- Never insert any other objects into the machine body.
- Never repair or remove plug and or power cord. Any repairs should be completed by qualified electrician.
- Always grab plug and pull straight out from the outlet. Never unplug by pulling on the power cord.
- Unplug the power supply before cleaning or storing the machine.

Specifications:

Model	246707
Voltage & Hertz	AC115V / 60Hz
Power Consumption & Current	740W/6.9A @ 80°F, 60% RH 900W/8.4A @ 86°F, 80% RH
Refrigerant	R410A/19.8 oz.
Dehumidify Capacity	11.2Gal/Day @ 80°F, 60% RH 18.1Gal/Day @ 86°F, 80% RH
Maximum Pressure	High Side: 522 PSIG Low Side: 240 PSIG
BCSC	15A
Compressor Input	RLA: 7.3A; LRA: 36.4A
Fan Motor	0.107 HP

**Read this manual thoroughly prior to installation, operation or maintenance.
 Failure to execute the instructions in this manual can cause personal injury or property damage.
 Water dispenses at a very high temperature. Failure to use properly can cause personal injury.
 Keep these instructions for future reference. For questions, visit globalindustrial.com
 or contact Customer Service at 1 (800) 645-2986.**

Crawl Space Commercial Dehumidifier

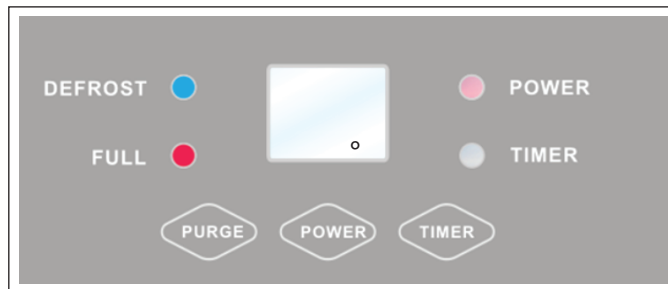
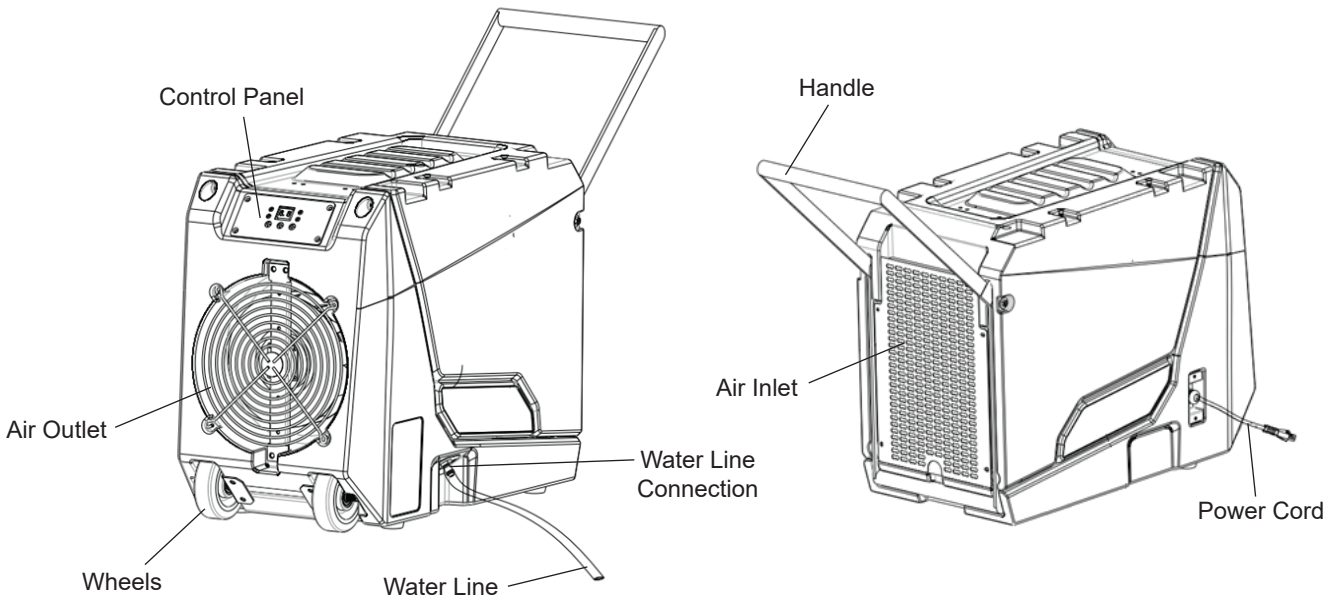

OPERATION

1. **POWER INDICATOR:** The “power” light indicator will turn on when the power cord is plugged in. The machine will automatically enter stand-by mode.
2. **POWER BUTTON:** Press to turn the dehumidifier on. The machine will automatically enter a continuous dehumidifying mode. Press this button again to turn the machine off and reenter stand-by mode.
3. **TIMER BUTTON:** Press this button to set the dehumidifying timer from 0-12 hours. Press one time to add 1 hour; the display screen will show the corresponding timer data set. To cancel the timer, set the timer data to “00” and the “TIMER” indicator light will turn off.
 - When the machine is in stand-by mode, user can set the timer for when the machine will turn on.
 - When the machine is in operating mode, user can set the timer for when the machine will turn off.
 - Press and hold the TIMER button for 3 seconds to check the current ambient room temperature. The display screen will show this data for 5 seconds, then revert back to current humidity.
 - Press and hold the TIMER button for 5 seconds and the ambient room temperature will remain on the display screen.

4. **PURGE BUTTON:** Press and hold for 3 seconds to manually pump and drain the machine. The “FULL” indicator will light up and the pump will drain for roughly 40 seconds. Once complete, the pump will stop and the “FULL” indicator light will turn off.
5. **SWITCH BETWEEN °C AND °F:** Press and hold “PURGE” and “TIMER” buttons at the same time for 3 seconds to switch between Celsius (°C) and Fahrenheit (°F) temperature display modes.
6. **DEFROST INDICATOR:** This indicator will light up once the machine automatically enters the defrosting mode. Once defrosting is complete, the “DEFROST” indicator light will turn off.
7. **FULL INDICATOR:** This indicator will light up when the water pump is full.
8. **DISPLAY SCREEN:** When the machine is running, the display screen will show the humidity of the inlet air. When setting a timer, the display screen will show the amount of hours set.
9. **MEMORY FUNCTION (EEPROM):** IF there is a power outage or the unit is turned-off, the machine will automatically restart according to its previous setting data once power is restored or the machine is turned back on.

Crawl Space Commercial Dehumidifier

AUTO-DRAINAGE

Connect the water line hose to the water drainage hole by quick connection. The machine will automatically drain by water pump through the water house when operating.

MAINTENANCE

WARNING: Always disconnect power supply before cleaning or conducting maintenance.

CLEANING:

- Clean the unit body with a soft damp cloth.
- DO NOT submerge into, or place water on the unit or control panel. Water may damage the electronic components of the unit.
- DO NOT use chemical solvents such as benzene, alcohol, gasoline or other heavy-duty cleaners. Otherwise, the surface may become damaged or deformed.

CLEANING THE AIR FILTER:

1. Gently pull out the air filter.
2. Use a vacuum cleaner to remove any dirt on the surface of the air filter. If the air filter is exceptionally dirty, carefully immerse it into warm water with a neutral detergent. Rinse and dry thoroughly.
3. Insert the filter back into the unit.

STORAGE:

1. Push the "PURGE" button to drain all water prior to transportation or storage.
2. Utilize the fold-able handle and wheels to transport the dehumidifier. Always transport and store machine upright.
3. If needed, machines are stackable to save space.

TROUBLESHOOTING

ERROR PROMPT & CODE RUNNING STATUS:

1. "E1" CODE: This code appears when the copper head sensor is damaged. The machine will keep running, but every 30 minutes, the compressor will stop for roughly 10 minutes, then continue to run. The machine will then repeat the cycle like this.
2. "E2" CODE: This code appears when the temperature and humidity sensor is damaged. The machine will keep running, but every 30 minutes, the compressor will stop for roughly 10 minutes, then continue to run. The machine will then repeat the cycle like this.
3. "E4" CODE: This code appears when the water pump's tank is full or there is a failure. The machine will automatically stop running.

WARNING: If the unit malfunctions, turn off the machine and unplug it immediately. Contact a licensed service technician.



WARNING: DO NOT dispose of electrical appliances in local landfills, or municipal waste locations. Many parts are recyclable. Contact your local government for information regarding the collection systems available in your area.