



USER MANUAL

Read this manual thoroughly prior to equipment set-up, operation or maintenance.



Model 243038

NEXEL® Merchandiser Freezer, 2 Door,
53-1/8"W x 31-7/8"D x 84-3/8"H (with casters)



Intertek



Intertek

For questions, please contact NEXEL® Customer Service at 1-800-245-6682 or visit www.nexelwire.com

WARNING

DANGER – RISK OF FIRE OR EXPLOSION. FLAMMABLE REFRIGERANT USED. TO BE REPAIRED ONLY BY TRAINED SERVICE PERSONNEL. DO NOT PUNCTURE REFRIGERANT TUBING.

PELIGRO - RIESGO DE INCENDIO O EXPLOSIÓN. CONTIENE REFRIGERANTE INFLAMABLE. DEBE SER REPARADO SOLAMENTE POR UN PERSONAL DE SERVICIO CALIFICADO.

DANGER – RISQUE DE FEU OU D'EXPLOSION. LE FRIGORIGÈNE EST INFLAMMABLE. CONFIER LES RÉPARATIONS À UN TECHNICIEN SPÉCIALISÉ. NE PAS PERFORER LA TUBULURE CONTENANT LE FRIGORIGÈNE.

CAUTION – RISK OF FIRE OR EXPLOSION. FLAMMABLE REFRIGERANT USED. CONSULT REPAIR MANUAL/OWNER'S GUIDE BEFORE ATTEMPTING TO SERVICE THIS PRODUCT. ALL SAFETY PRECAUTIONS MUST BE FOLLOWED.

ATENCIÓN - RIESGO DE INCENDIO O EXPLOSIÓN. CONTIENE REFRIGERANTE INFLAMABLE. CONSULTE EL MANUAL DE REPARACIÓN / GUÍA DEL PROPIETARIO ANTES DE INTENTAR DAR SERVICIO A ESTE PRODUCTO. DEBEN CUMPLIR CON TODAS LAS PRECAUCIONES DE SEGURIDAD.

ATTENTION – RISQUE DE FEU OU D'EXPLOSION. LE FRIGORIGÈNE EST INFLAMMABLE. CONSULTER LE MANUEL DU PROPRIÉTAIRE/GUIDE DE RÉPARATION AVANT DE TENTER UNE RÉPARATION. TOUTES LE MESURES DE SÉCURITÉ DOIVENT ÊTRE RESPECTÉES.

CAUTION – RISK OF FIRE OR EXPLOSION DUE TO PUNCTURE OF REFRIGERANT TUBING; FOLLOW HANDLING INSTRUCTIONS CAREFULLY. FLAMMABLE REFRIGERANT USED.

ATENCIÓN - RIESGO DE INCENDIO O EXPLOSIÓN DEBIDO A LA PERFORACIÓN DE LA TUBERÍA REFRIGERANTE; SIGA LAS INSTRUCCIONES DE MANIPULACIÓN CON CUIDADO. CONTIENE REFRIGERANTE INFLAMABLE.

ATTENTION – RISQUE DE FEU OU D'EXPLOSION SI LA TUBULURE CONTENANT LE FRIGORIGÈNE EST PERFORÉE; SUIVRE LES INSTRUCTIONS DE MANUTENTION AVEC SOIN. LE FRIGORIGÈNE EST INFLAMMABLE.

CAUTION – RISK OF FIRE OR EXPLOSION DUE TO FLAMMABLE REFRIGERANT USED. FOLLOW HANDLING INSTRUCTIONS CAREFULLY IN COMPLIANCE WITH LOCAL GOVERNMENT REGULATIONS.

ATENCIÓN – RIESGO DE INCENDIO O EXPLOSIÓN DEBIDO A REFRIGERANTE INFLAMABLE UTILIZADO. SIGA LAS INSTRUCCIONES DE MANEJO DE ACUERDO CON LAS REGULACIONES DEL GOBIERNO LOCAL.

ATTENTION – RISQUE DE FEU OU D'EXPLOSION EN RAISON DU REFRIGERANT INFLAMMABLE UTILISE. SUIVRE LES INSTRUCTIONS DE MANUTENTION AVEC SOIN CONFORMÉMENT AUX RÈGLEMENTATION GOUVERNEMENTALE LOCAUX.

SPECIFICATIONS

Dimensions	53-1/8"W x 31-7/8"D x 84-3/8"H (with casters)
Number of Doors	2
Number of Shelves	8
Casters	Yes
Capacity (Cubic Ft.)	45
HP	1
Voltage	115
Amps	10.6
Plug Type	NEMA 5-20P
Temperature Range	-8°F to 0°F
Exterior Construction	Powder Coated Steel
Interior Construction	Painted Aluminum
Shelf Construction	Epoxy-Coated Steel
Refrigerant	R290
Unit Weight	437 lbs.
Hertz	60 Hz
Phase	1
Cord Length	7-ft.
Lighting	LED
Warranty	1 Year

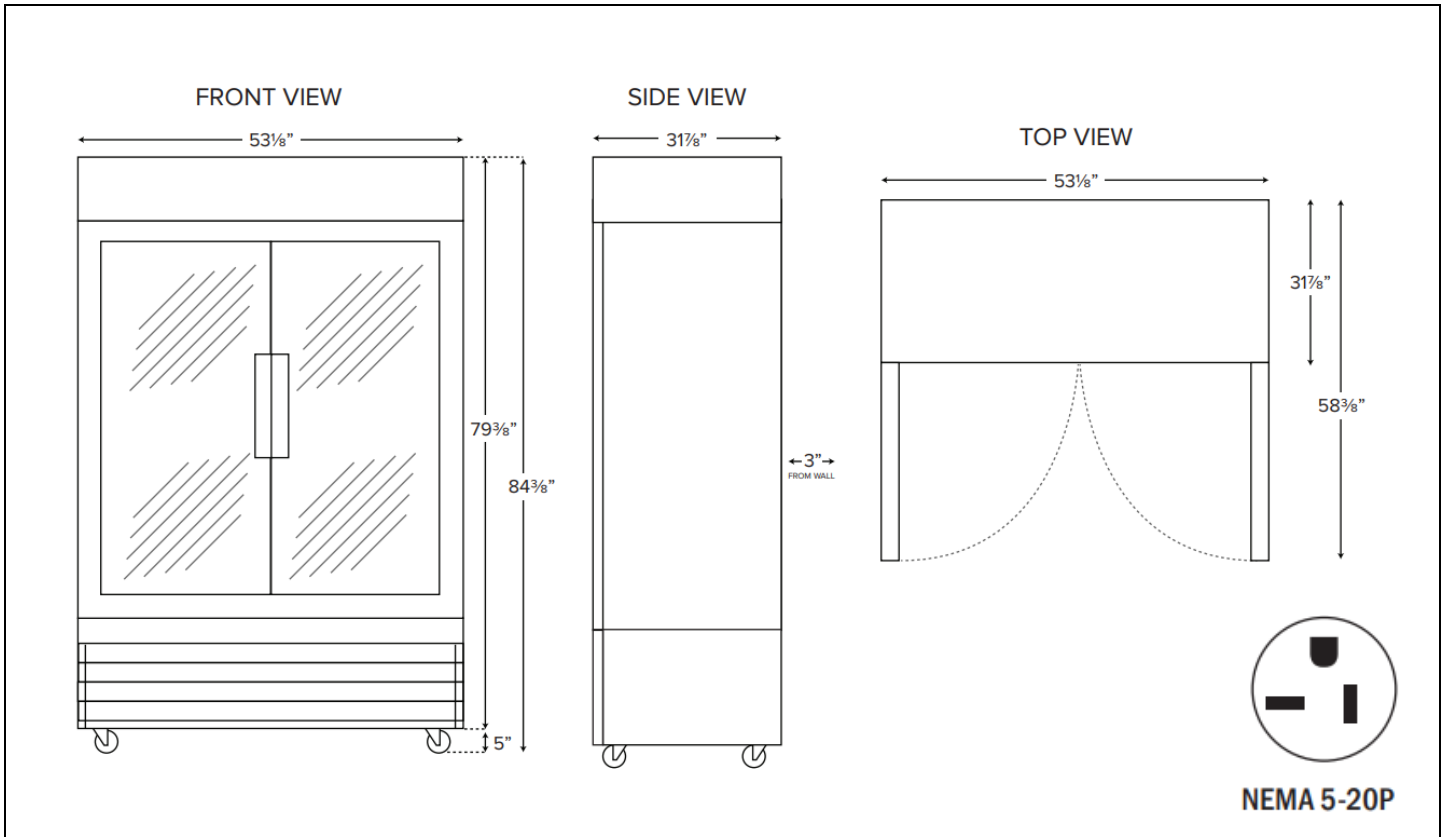

INSTALLATION

Read this entire manual thoroughly prior to equipment set-up, operation and/or maintenance.

IMPORTANT:

- If the freezer has recently been transported on its side, allow the unit to stand upright for a minimum of 24 hours before plugging it in.
- Make sure all shelves and accessories are properly installed before plugging in the unit.
- Do not attempt to remove or repair any component of the unit. Consult an authorized service technician for all servicing and repair needs.
- Do not hang on doors or stand inside the unit.
- Make sure the freezer has reached the desired temperature before loading.

Location Guide



- Install unit on a strong and leveled surface. If the surface is uneven, the freezer may be noisy or malfunction.
- Install unit in an indoor, well ventilated area. Outdoor use may cause decreased efficiency and damage to the unit. Avoid direct sunlight.
- For best performance, allow 6" of clearance on sides and the back of the unit during operation.
- Avoid installation in high humidity and/or dusty areas. High humidity can cause the unit to rust and may decrease efficiency. Dust collected on the condenser coil may cause unit to malfunction.
- Select a location away from heat and moisture-generating equipment. High ambient temperatures may cause the compressor to malfunction.

Electrical Warnings



- Ensure that the required voltage is being supplied at all times.
- The freezer should be plugged into a grounded and properly-sized electrical outlet with appropriate overcurrent protection. Each unit should have its own dedicated outlet. Please refer to the electrical requirements on the unit's nameplate.
- Do not use extension cords.
- Ensure the freezer is not resting on or against the electrical cord.
- If the unit is not in use for a long period of time, unplug it from the outlet.
- To avoid shock and fire hazards, do not plug in or unplug the unit with wet hands.
- After unplugging the unit, wait 10 minutes prior to plugging it back in. Failure to do so could cause damage to the compressor.





TEMPERATURE CONTROLS

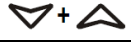

SET	To display the set temperature. In programming mode it selects a parameter or confirms an operation.
	To start a manual defrost.
	In programming mode it browses the parameter codes or increases the displayed value.
 AUX	In programming mode it browses the parameter codes or decreases the displayed value.

KEY COMBINATIONS

	To Lock or Unlock the Keyboard
SET + 	To Enter Programming Mode
SET + 	To Return to Room Temperature Display

LED	MODE	INDICATES
	On	Compressor Enabled
	Flashing	Anti-Short Cycle Delay Enabled (AC Parameter)
	On	Defrost in Progress
	Flashing	Dripping in Progress
	On	Fans Output Enabled
	Flashing	Fans Delay After Defrost
	On	Measurement Unit
	Flashing	Programming Mode

NOTE: Your new freezer is already factory-set to run at optimum temperatures for food safety and should require no adjustments. Your freezer is set to cycle between a minimum temperature of -5°F and a maximum temperature of 2°F. Adjusting the temperature changes the minimum temperature your unit will run at. Your freezer will not run constantly at this temperature setting.

HOW TO VIEW THE SET TEMPERATURE

1. Push and immediately release the **SET** key, the set temperature will be displayed.
2. To return to standard view, wait about 5 seconds or push and immediately release the **SET** key again.

HOW TO CHANGE THE SET TEMPERATURE

1. Push and hold the **SET** key for 2 seconds.
2. The °F LED will start to blink and the current temperature will be displayed.
3. To change the set temperature push the \blacktriangle or \blacktriangledown arrows.
4. Push the **SET** key to store the new temperature or wait 10 seconds and new temperature will automatically be set.

HOW TO START A MANUAL DEFROST

NOTE: Your new freezer is pre-programmed to run automatic defrost cycles at preset intervals and for pre-determined durations. To run a manual defrost cycle at any time, follow these instructions:

1. Push and hold the  key for 2 seconds.
2. Repeat to stop the defrost cycle.

Freezer coils are defrosted electrically. Automatic defrost timers automatically initiate at pre-set intervals and for a predetermined duration.

OPERATION/MAINTENANCE

NOTE: It is strongly recommend that any servicing be performed by an authorized service technician.

- During maintenance and cleaning, please unplug the unit.

LOADING PRODUCTS

- Do not block the inside air duct/fan at the top of your freezer. Maintain a minimum clearance of 4" between products and the fan at all times.
- Ensure all shelves are level and properly secured prior to loading products.
- Do not store flammable and/or explosive gas or liquids inside the unit.

CLEANING THE CONDENSER COIL

- For efficient operation, keep the condenser surface free of dust, dirt and lint.
- We recommend cleaning the condenser coil at least once per month.
- Clean the condenser with a commercial condenser coil cleaner, available from any kitchen equipment retailer.

CLEANING THE FAN BLADES AND MOTOR

- If necessary, clean the fan blades and motor with a soft cloth.
- If it is necessary to wash the fan blades, cover the fan motor to prevent moisture damage.

CLEANING THE INTERIOR OF THE UNIT

- When cleaning the cabinet interior, use a solvent of warm water and mild soap.
- Do not use steel wool, caustic soap, abrasive cleaners or bleach that may damage the interior finish of the cabinet.
- Wash door gaskets on a regular basis, preferably weekly. Simply remove the door gasket from the frame of the door, soak it in warm water and soap for 30 minutes. Dry with soft cloth and replace.
- Check door gaskets for proper seal after they are replaced.
- Periodically remove the shelves and shelf brackets from the unit, and clean them with a mild soap and warm water.

TROUBLESHOOTING

PROBLEMS	CAUSES	SOLUTIONS
Compressor is Not Running	Fuse blown or circuit breaker tripped.	Replace fuse or reset circuit breaker.
	Power cord unplugged.	Plug in power cord.
	Thermostat set too high.	Set thermostat to lower temperature.
	Cabinet in defrost cycle.	Wait for defrost cycle to finish.
Cabinet Temperature is too Warm	Thermostat is set too high.	Set thermostat to lower temperature.
	Airflow is blocked.	Re-arrange products to allow for proper air flow. Make sure there is at least four inches of clearance from the fan.
	Low refrigerant levels.	Contact a service technician to check refrigerant levels.
	Door is slightly ajar.	Make sure door is completely closed.
Interior Light is Not Working	Poor switch connection.	Turn off light switch and turn it back on.
	Bulb is not connected.	Make sure the bulb is correctly inserted in the socket.
	Bulb has burned out.	Replace the bulb.
Condensation is Collecting on the Cabinet and/or Floor	Gasket is not sealing properly.	Clean, repair, or replace the gasket as necessary.