

LockUp E/Ex is a keypad lock designed for LockUp lockers in shared use applications. The user chooses an available locker then enters a self-selected 4-digit code to lock and unlock. Once unlocked, the locker is available for a different user. Management staff uses Manager Flex Key(s) for locker access and audit/inspection.

Lock Parts

Front Unit

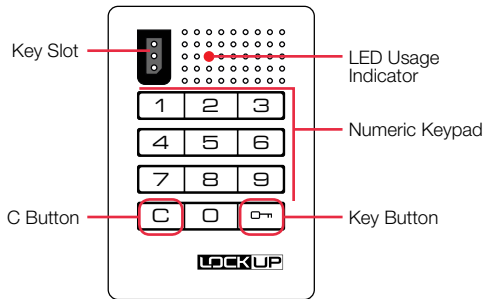

Rear Unit

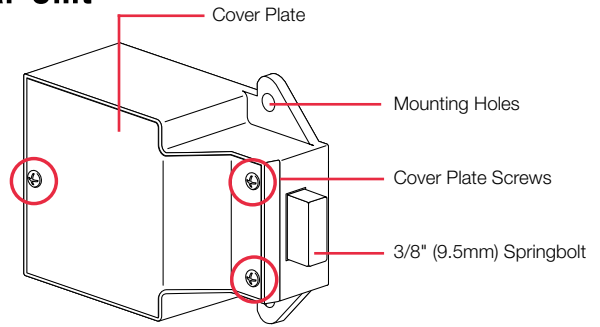

Keys



User Key



Manager Key

Operates the lock	•	•
Overrides user access	•	•
Allows management inspection	•	•
Provides external power	•	•

Key Insertion

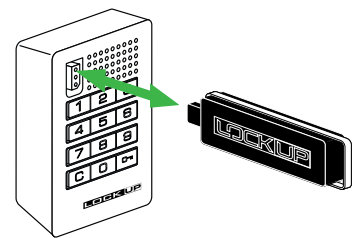

LockUp logo must face left.

Programming Instructions

Initial Setup

LockUp locks may arrive set up to operate with registered Manager Flex Key(s). If the lock operates by pressing **C** **C-**, the lock must be set up to allow full operation.

- Go to the lock requiring setup.
- Make sure the locker door is open and the lock is in the unlocked position (bolt is retracted).
- Touch the Manager Flex Key to the key slot until a two-tone beep is heard and the bolt extends.
- Touch the Manager Flex Key to the key slot again to retract the bolt.

Programming Instructions

Add Manager Flex Key(s)

At least one Manager Flex Key is required for the lock system. For additional Manager Flex Key(s), contact your LockUp Product Representative.

- a. Request an additional copy of your Manager Flex Key – “Match Previous”.
- b. Upon receipt, no additional programming is required. The additional Manager Flex Key(s) “match” the Manager Flex Key(s) already registered to operate the lock(s).

Replace Lost/Stolen Manager Key(s)

Replacement Manager Flex Key(s) must be purchased and registered to the lock(s) to prevent lost/stolen Manager Flex Key(s) from accessing a lock. All remaining Manager Flex Key(s) must also be replaced as they “match” the lost/stolen Manager Flex Key.

- a. Collect all remaining Manager Flex Key(s).
- b. Request the number of replacement Manager Flex Keys from your LockUp Product Representative – “Replacement Key”.
- c. Upon receipt, touch one replacement Manager Flex Key to the key slot until a two-tone beep is heard. If multiple replacement Manager Flex Keys operate the lock(s), only one replacement Manager Flex Key is required to be registered as they all “match”.
- d. Repeat above step for each lock.
- e. All previously registered Manager Flex Keys will no longer operate the lock; discard/destroy them.

Auto Unlock

Each lock can be programmed to auto unlock after a set number of hours. For E models, the default setting is ON (flash while the lock is in use). For Ex models, the default setting is OFF.

To turn off Auto Unlock:

- a. Press **[C] [07] [9] [4] [07]**. The LED will start to flash.
- b. Touch the Manager Flex Key to the key slot until a two-tone beep is heard and the LED turns off.
- c. Repeat above steps for each lock.

To turn on Auto Unlock (unlock after 12 hours):

- a. Press **[C] [07] [9] [3] [07]**. The LED will start to flash.
- b. Touch the Manager Flex Key to the key slot until a two-tone beep is heard and the LED turns off.
- c. Repeat above steps for each lock.

To turn on Auto Unlock (unlock after a set number of hours):

- a. Press **[C] [07] [9] [5] [07]** then touch the Manager Flex Key to the key slot until a two-tone beep is heard and the LED turns on.
- b. Set the number of hours: Press **[1] - [9] [9]** then **[07]**. Two sets of two-tone beeps will be heard and the LED will turn off.

(number of hours)

For example: **[2] [0] [07]** sets the lock to auto unlock after 20 hours.

- c. Repeat above steps for each lock.

LED Usage Indicator

Each lock can be programmed to have the LED flash or not flash while the lock is in use. For E models, the default setting is ON (flash while the lock is in use). For Ex models, the default setting is OFF.

To turn off the LED Usage Indicator:





- a. Press **[C] [07] [9] [2] [07]**. The LED will start to flash.
- b. Touch the Manager Flex Key to the key slot until a two-tone beep is heard and the LED turns off.
- c. Repeat above steps for each lock.

To turn on the LED Usage Indicator:

- a. Press **[C] [07] [9] [1] [07]**. The LED will start to flash.
- b. Touch the Manager Flex Key to the key slot until a two-tone beep is heard and the LED turns off.
- c. Repeat above steps for each lock.

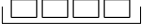
Operating Instructions

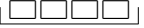
Operate with a User Code:

- To lock: Close the door, then press   
- To unlock: Press    , then open the door.*

(any 4-digit code)

(the same 4-digit code)

Operate with a User Key:

- To lock: Close the door, then touch any User Key to the key slot.
- To unlock: Touch the same User Key to the key slot, then open the door.

Operate with a Manager Flex Key**:

- To lock: Close the door, then touch a registered Manager Flex Key to the key slot.
- To unlock: Touch a registered Manager Flex Key to the key slot, then open the door.

*The lock will go into Sleep Mode after 3 consecutive incorrect entries.

**If a Manager Flex Key is used to unlock and relock, the previous user Code or User Key will continue to operate the lock.

Support

Sleep Mode

After three consecutive incorrect user code entries to unlock, the lock will go into Sleep Mode for one minute and for an additional minute for each subsequent incorrect entry. The keypad is disabled while in Sleep Mode.

Error Condition Indicator:

Locks emit feedback when an error condition exists.

10 rapid beeps:

The lock is binding which means that either door alignment or items in the locker are preventing the lock from operating. Press on the door while operating the lock. If error condition persists, contact LockUp Support for assistance.

2 sets of three beeps:

The batteries are low. Replace the batteries.

1 beep:

The lock does not recognize the User Code or Key.

Does not unlock with the User Code or User Key:

The lock does not recognize the User Code or User Key. Operate the lock with a registered Manager Flex Key.

Does not operate with a Manager Flex Key:

The lock does not recognize the Manager Flex Key. Contact LockUp Support. For immediate access, operate with another registered Manager Flex Key.

No audible feedback when **[C]** is pressed:

- The lock may be in Sleep Mode or the batteries need to be replaced. For immediate access, operate with a registered Manager Flex Key. Press **[C]** to test; if no audible feedback, replace the batteries.
- If error condition persists, loosen the mounting hardware and test.
- If error condition persists, remove the lock and assemble in your hand to test. If the door is locked or damage is visible, contact LockUp Support.
- If the lock functions when assembled in your hand, reinstall and test again.
- If error condition persists, contact LockUp Support.

Battery Replacement

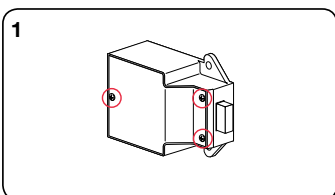

1 The batteries are located in the rear unit of the lock.

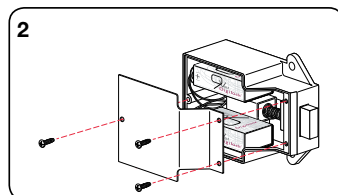

2 Remove the screws and the cover plate.

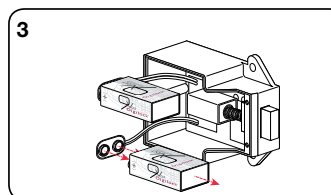

3 Pull the batteries from the rear housing and gently pull from the connector snaps.

Replace the two 9V batteries.

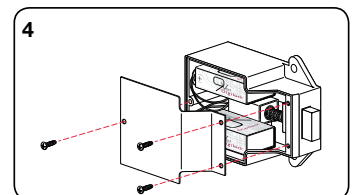

4 Reinstall the batteries and screw the cover plate in place.