

STEP 6 • PASO 6

What You Need (Lo que necesita):

x2

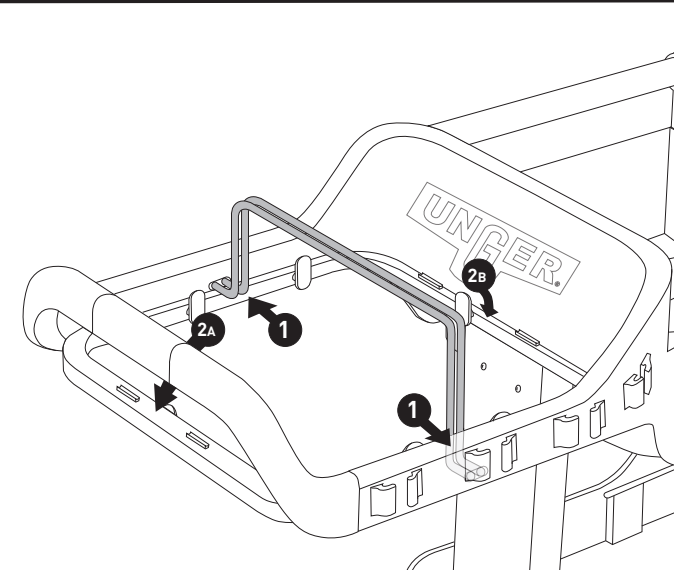
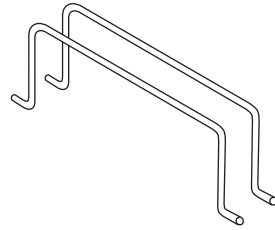

Insert and secure the trash bag liner.
Inserte y fije el forro para basura.

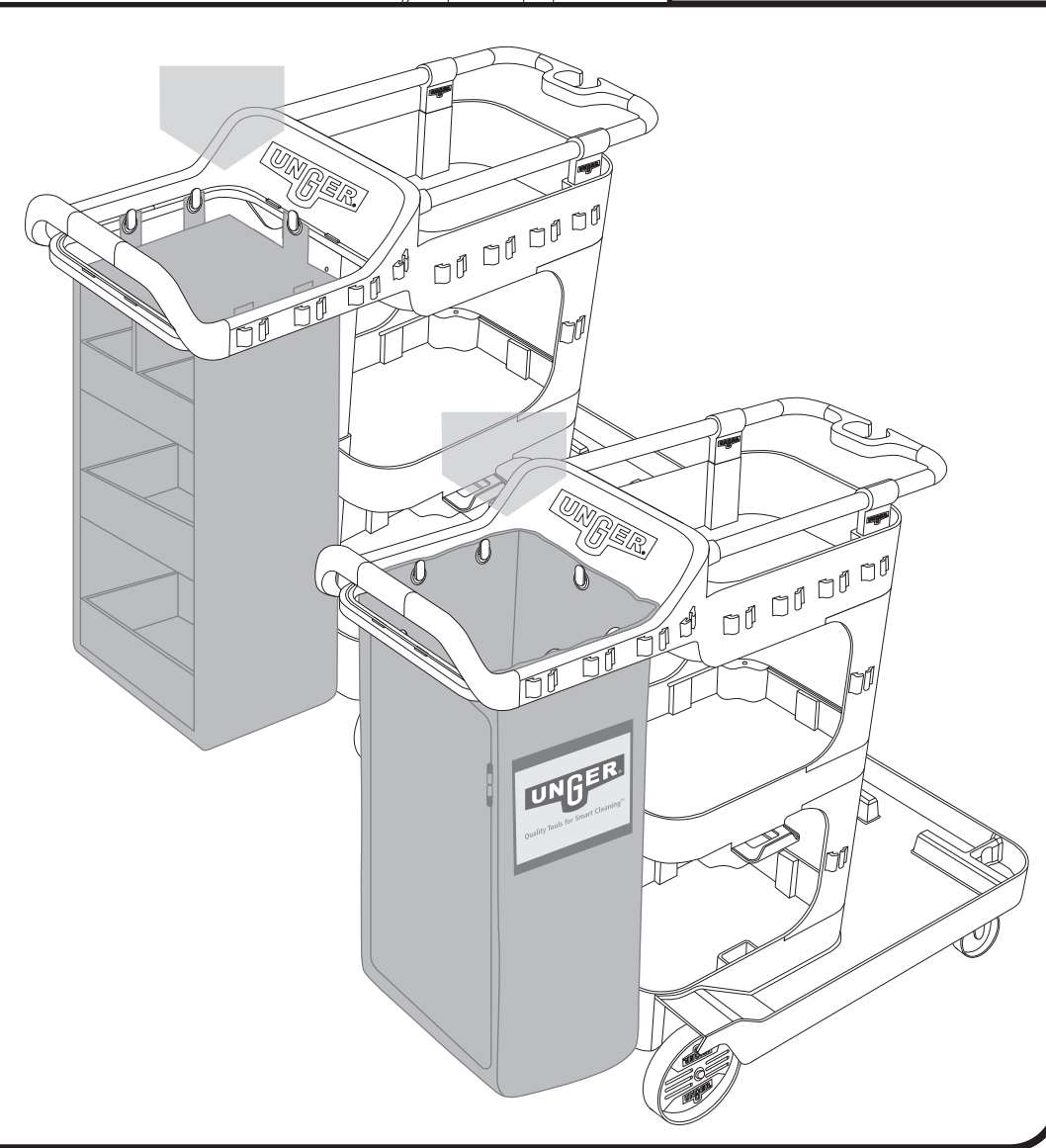
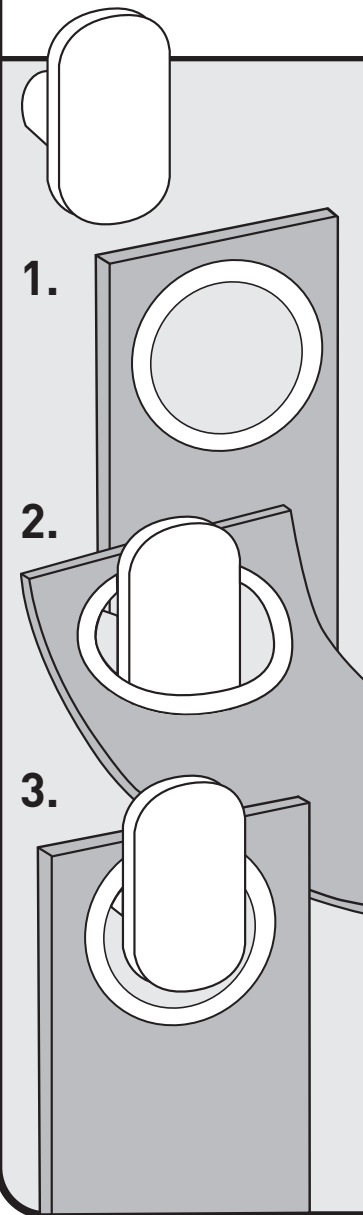
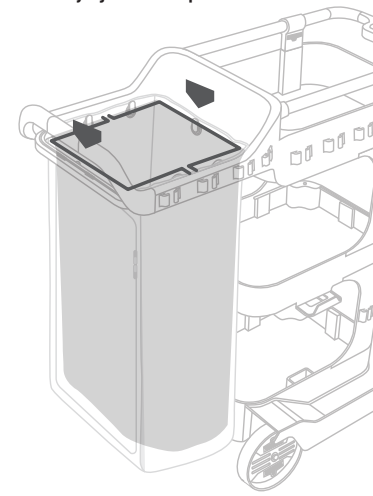

UNGER
RESTROOM_RX
A HIGHER LEVEL OF CLEAN_X

ASSEMBLY INSTRUCTIONS
INSTRUCCIONES DE MONTAJE

CONTENTS • CONTENIDO

x1

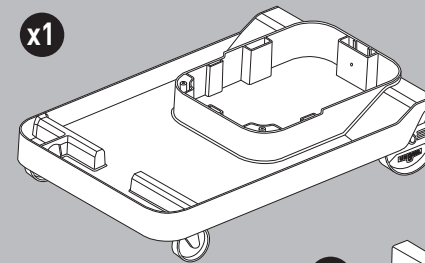

x2

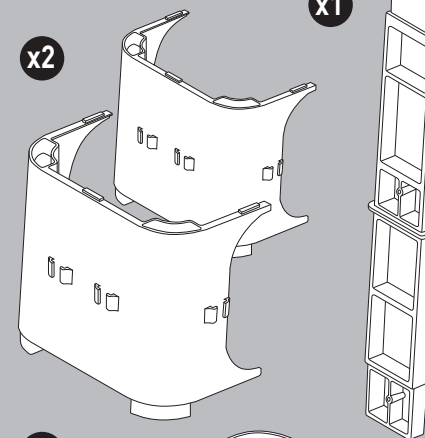

x1

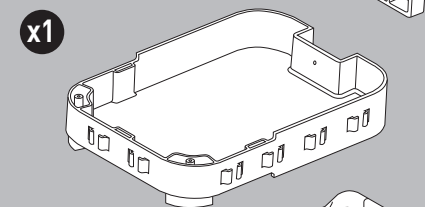

x1

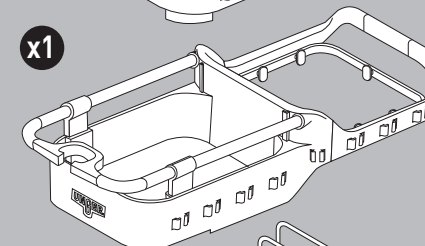

x2

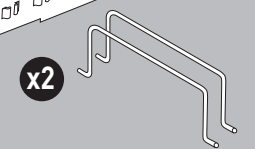

x12

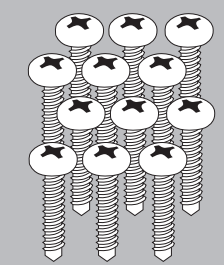

NOT INCLUDED
NO SE INCLUYE

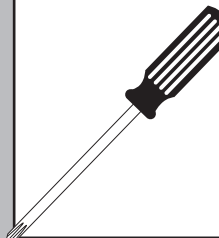

STEP 1 • PASO 1

What You Need (Lo que necesita):

x1

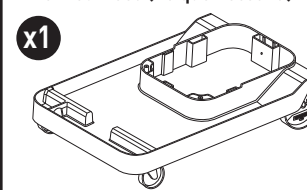

x1

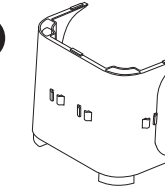

x2

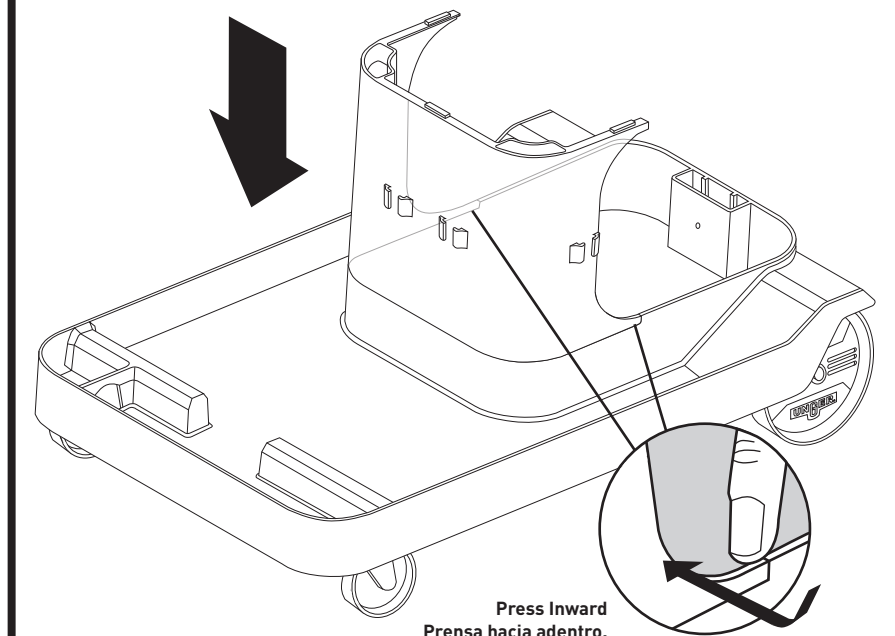
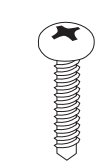

Press Inward
Prensa hacia adentro.

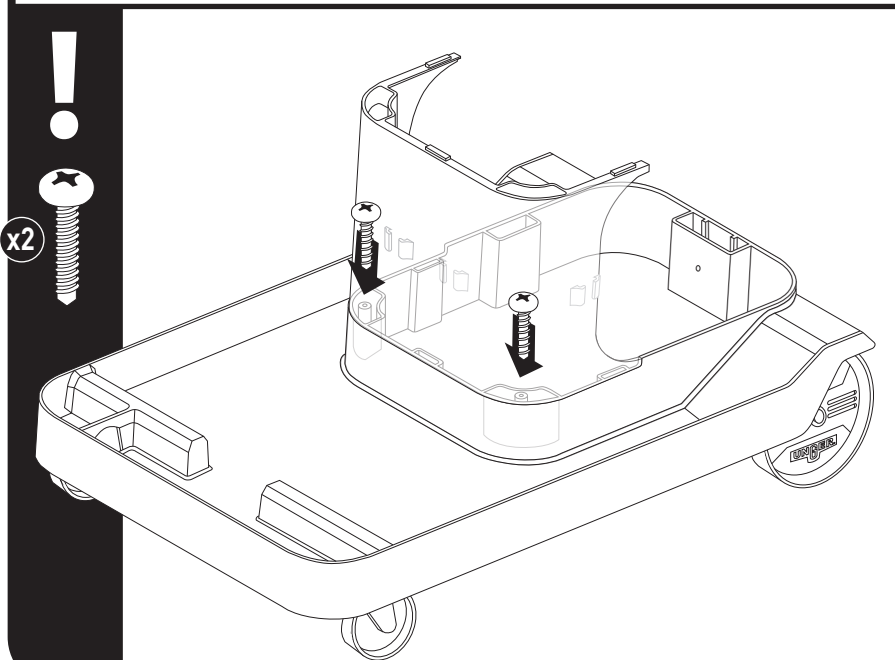

Unger Enterprises Inc.

425 Asylum Street • Bridgeport, CT 06610 • Tel: (1) 800.431.2324 • Fax: (1) 800.376.1988

E-mail: unger@ungerglobal.com • www.ungerglobal.com

STEP 2 • PASO

What You Need (Lo que necesita):

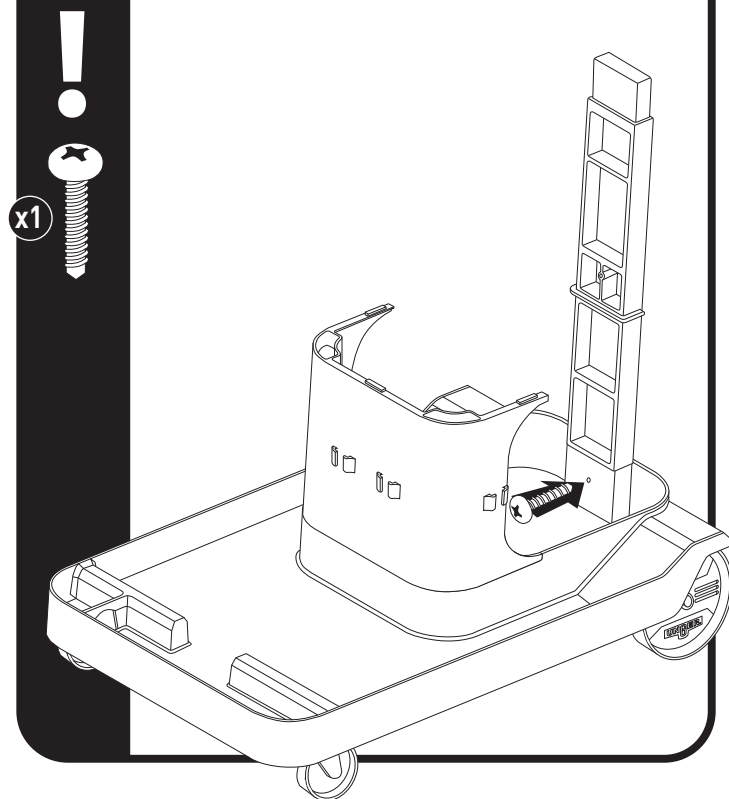
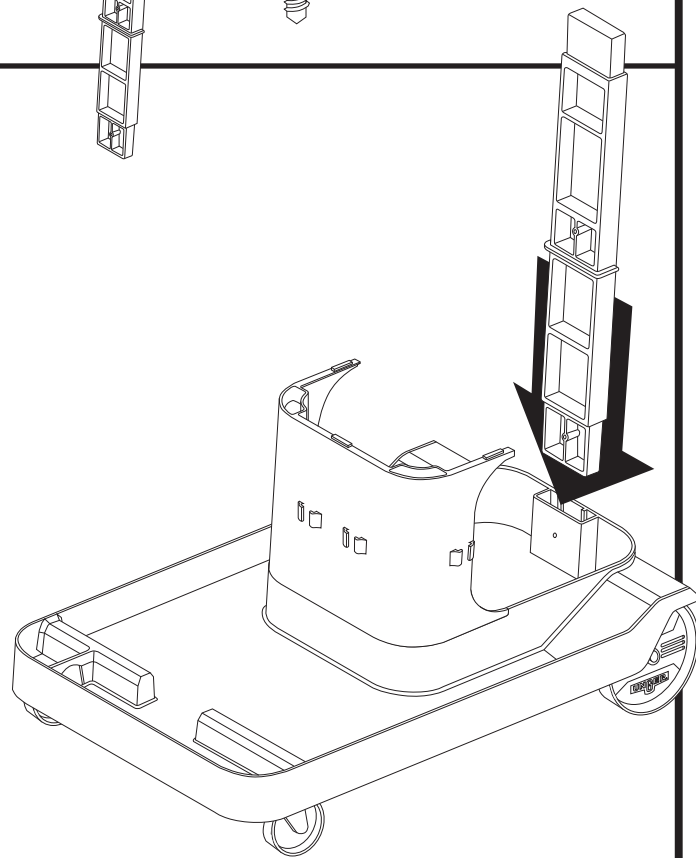
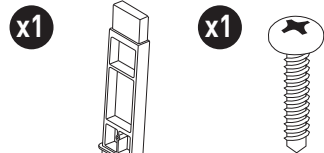

STEP 3 • PASO 3

What You Need (Lo que necesita):

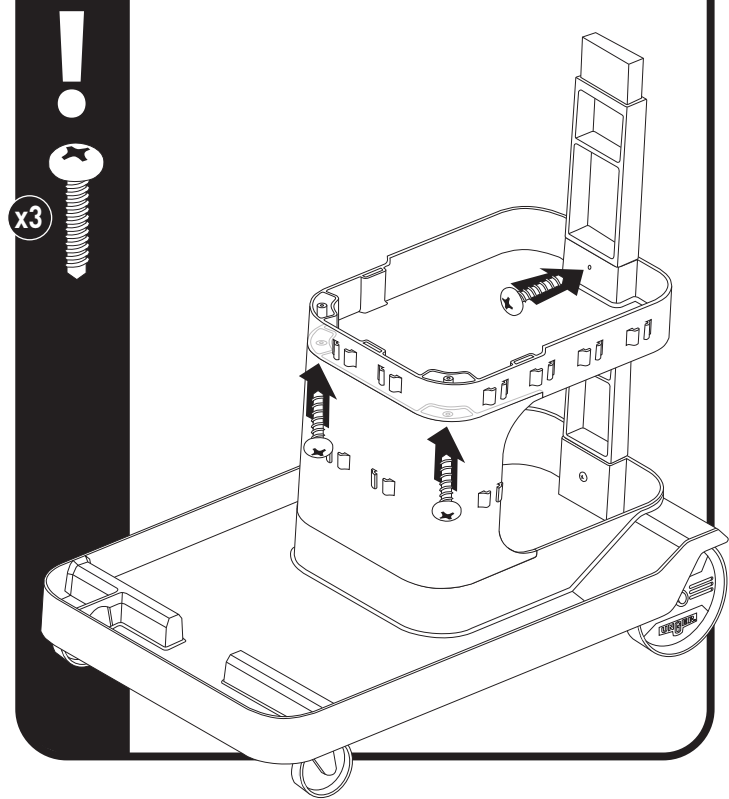
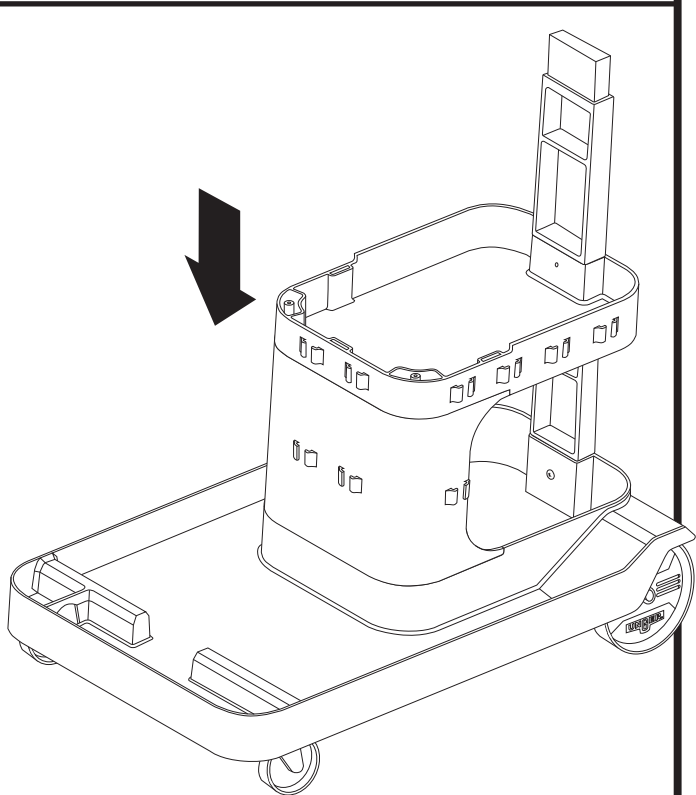
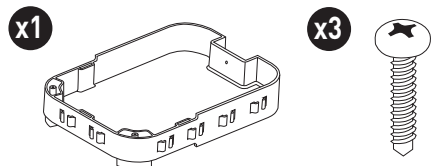

STEP 4 • PASO 4

What You Need (Lo que necesita):

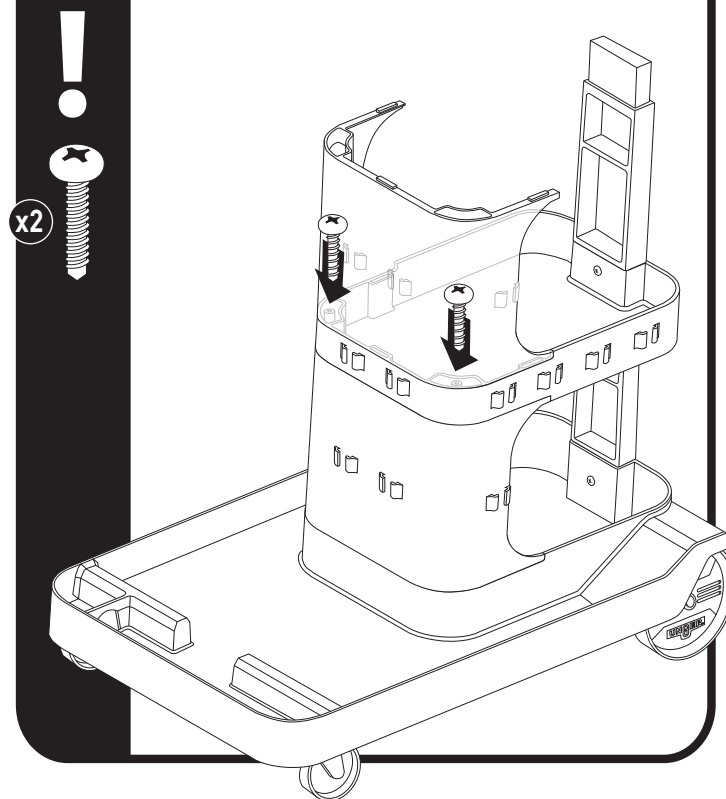
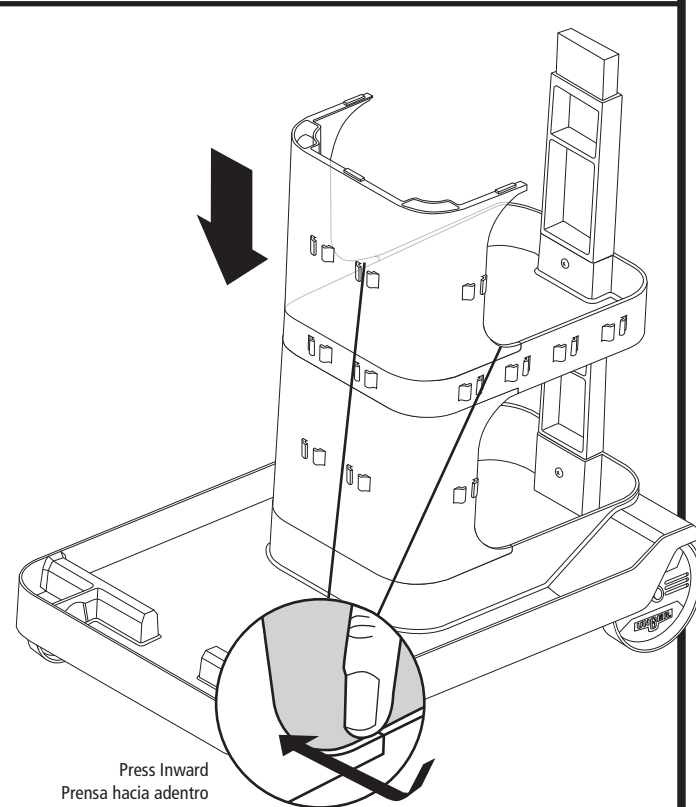
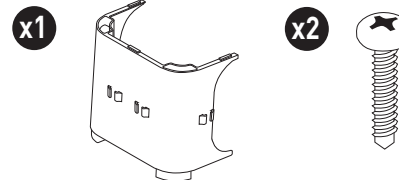

STEP 5 • PASO 5

What You Need (Lo que necesita):

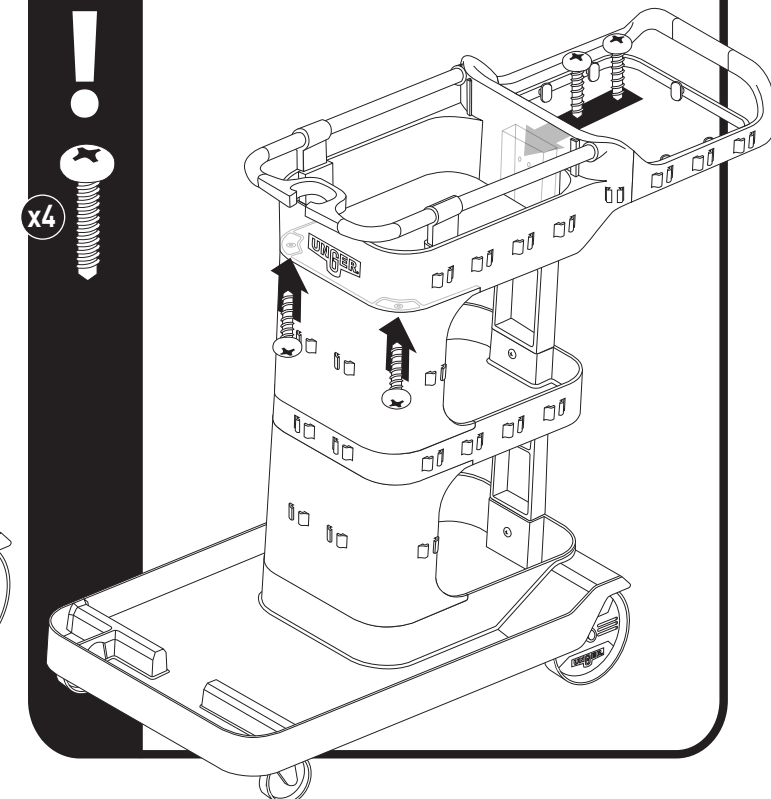
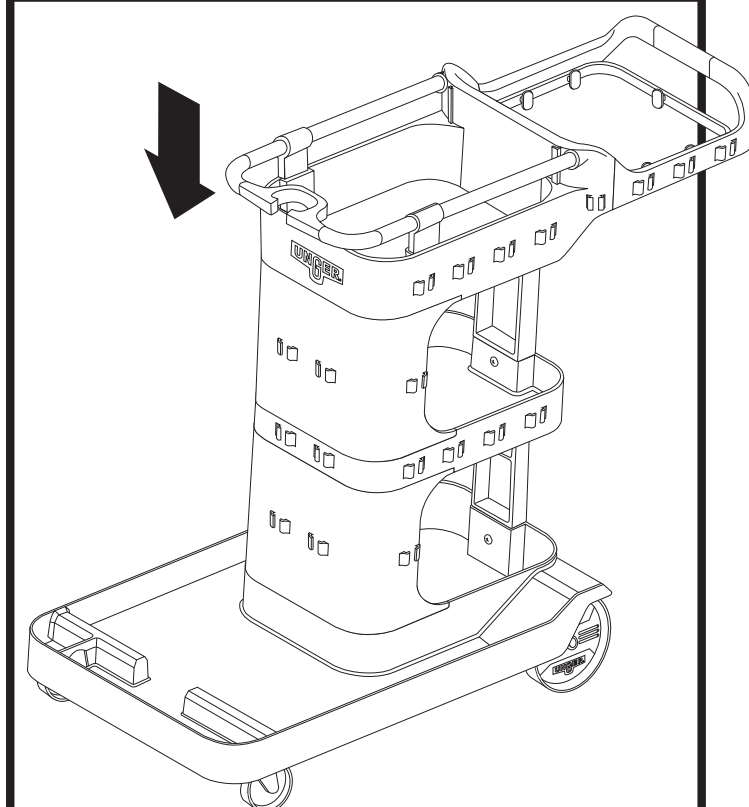
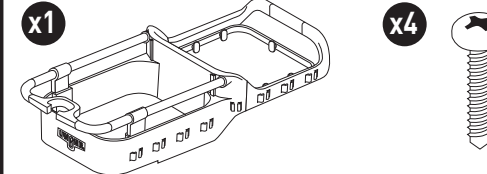

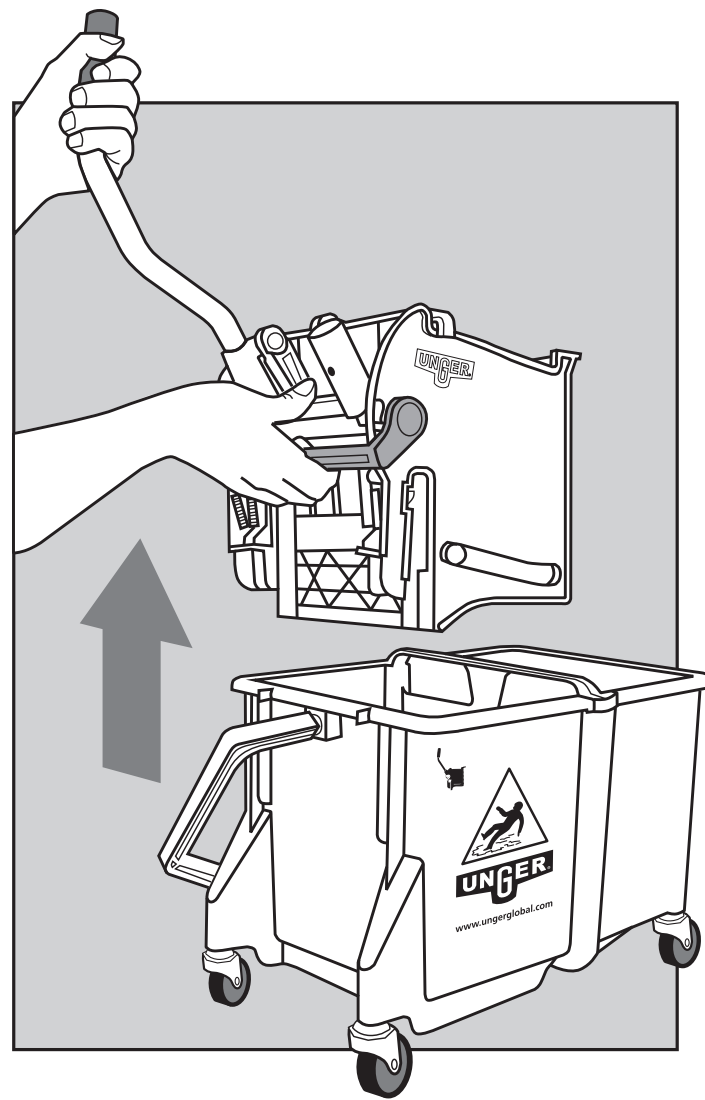
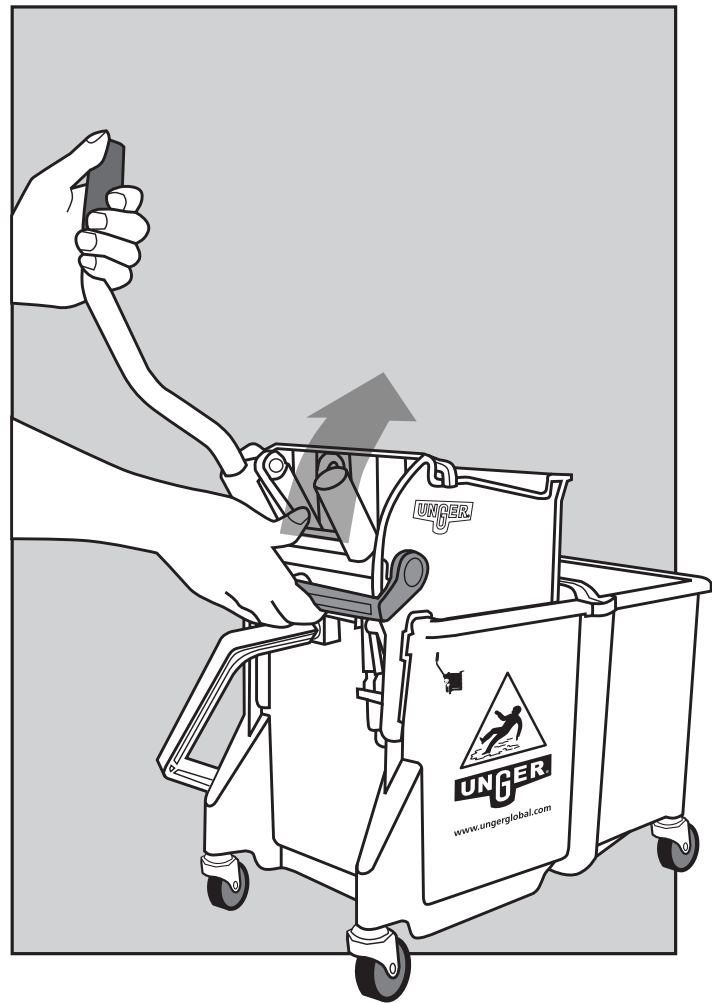

STEP 10: To remove the press, lift the handle and lift upwards.
PASO 10: Para quitar la prensa, levante el mango gris hacia arriba.

STEP 2:
Tap in casters (x4)
with a mallet.

PASO 2:
Instale las ruedecillas
(x4) con un mazo.

STEP 1:
Tap in sleeves (x4)
with a mallet.

PASO 1:
Colocar tubo plastico (x4).

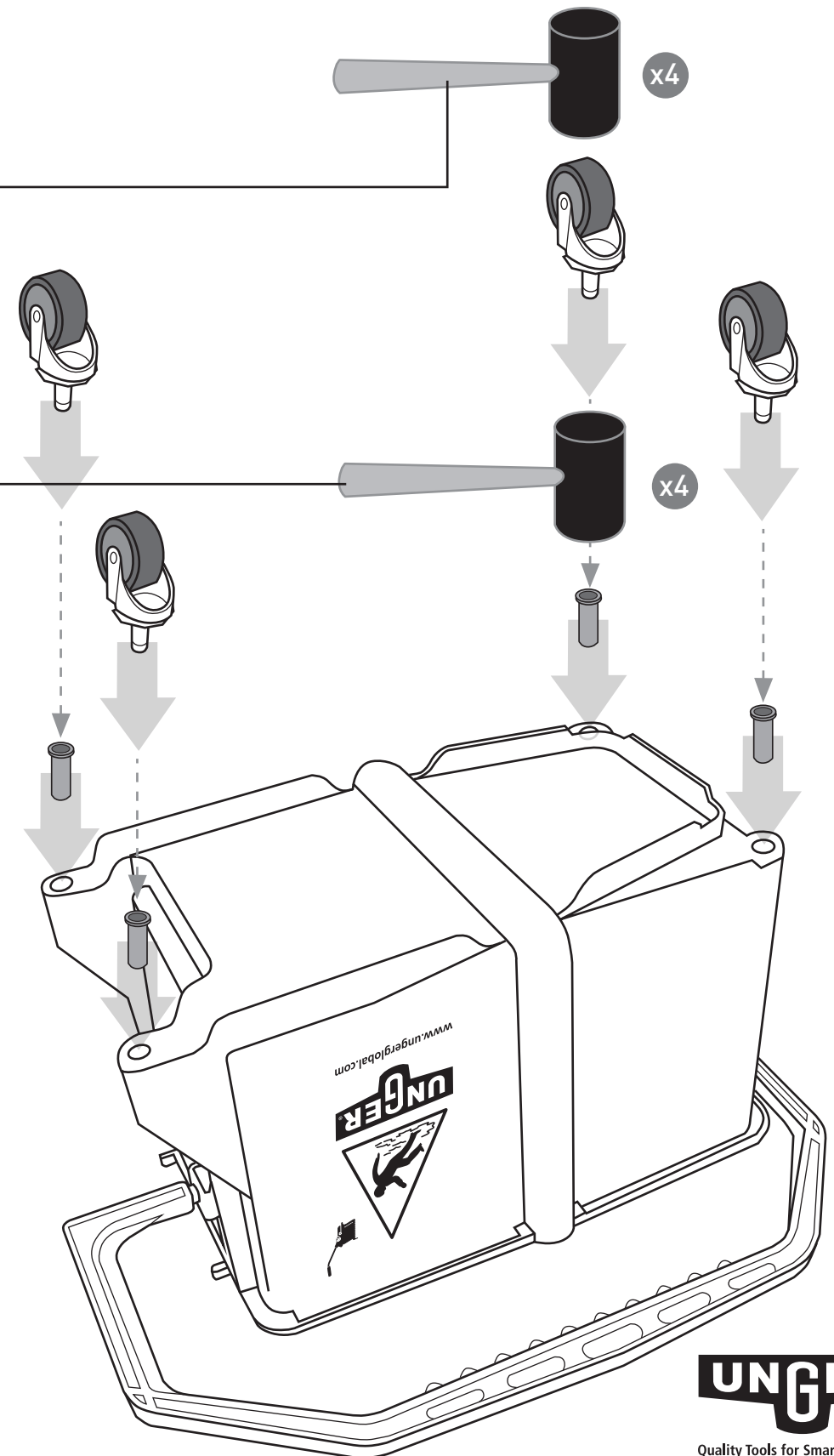

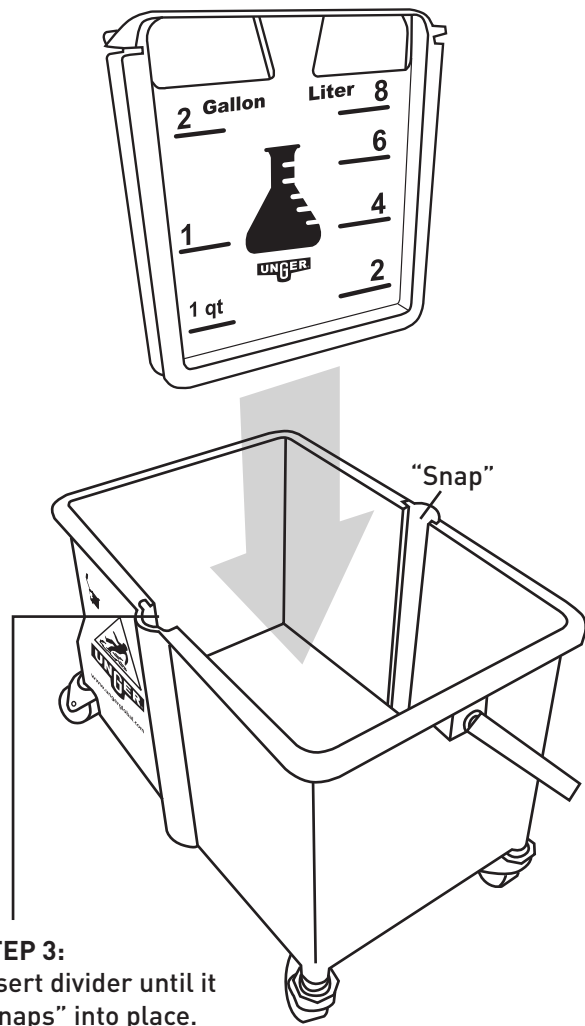

STEP 3:
Insert divider until it "snaps" into place. Be sure the chemical symbol is facing front and the water symbol is facing the back (where the press attaches).

PASO 3:
Inserte el separador hasta que quede fijo en su lugar. Asegúrese de que el símbolo químico quede orientado hacia el frente y el del agua hacia atrás (donde se conecta la prensa).

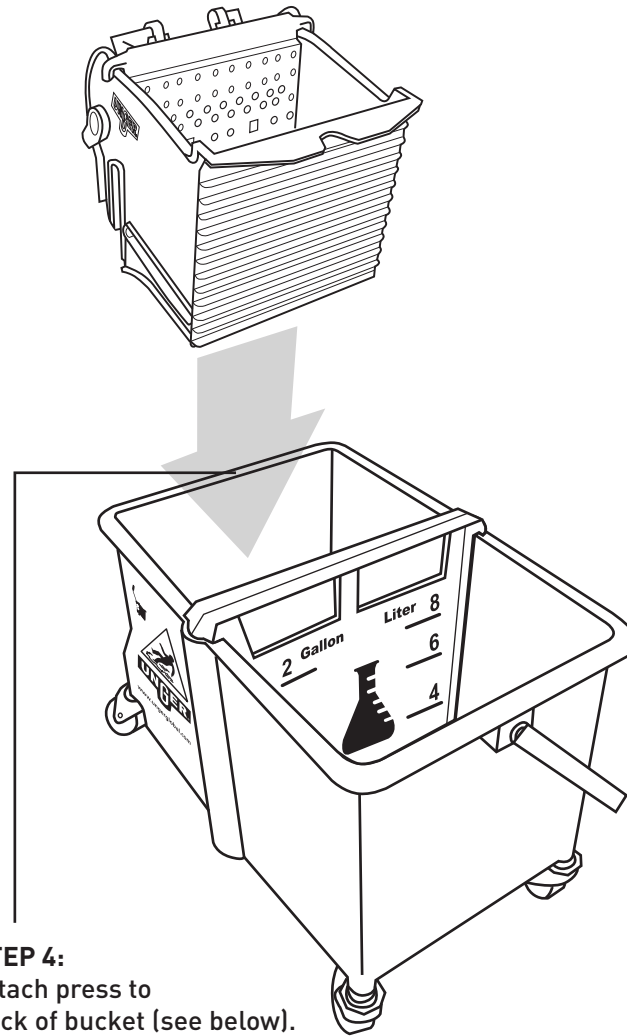

STEP 4:
Attach press to back of bucket (see below).

PASO 4:
Instale la prensa en la parte posterior del cubo (vea abajo).



Look for the press icon on the back half of the bucket. The press attaches on that side and locks into place.

Busque el icono de la prensa en la mitad posterior del cubo. La prensa se instala en ese lado y se fija en su lugar.

Insert Handle for Right-Handed Use
Inserte el mango para su uso con la mano derecha

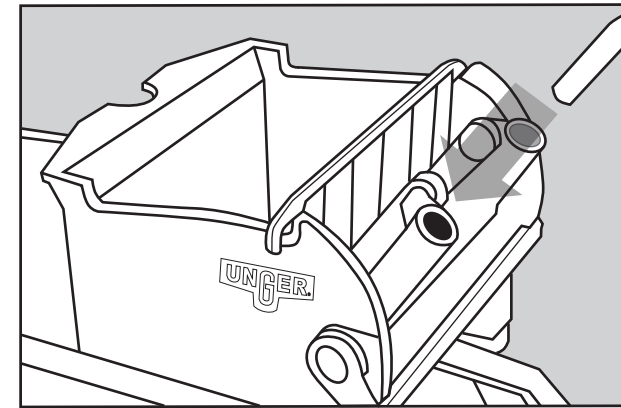

STEP 5: Insert handle into press.

PASO 5: Inserte el mango en la prensa.

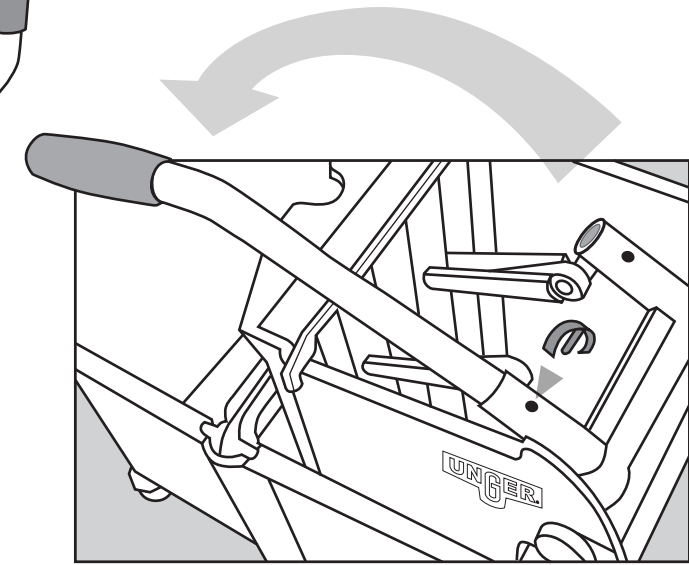

STEP 6: Insert clip to secure handle.

PASO 6: Inserte el sujetador para fijar el mango.

Insert Handle for Left-Handed Use
Inserte el mango para su uso con la mano izquierda.

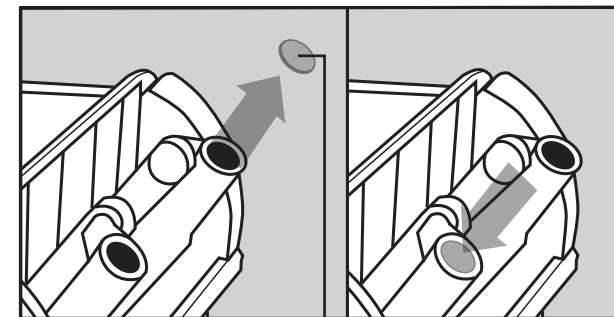

STEP 7: Remove plastic cap from left handle insert and place on right side.

PASO 7: Quite la tapa de plástico del conector del mango y colóquela en el lado derecho.

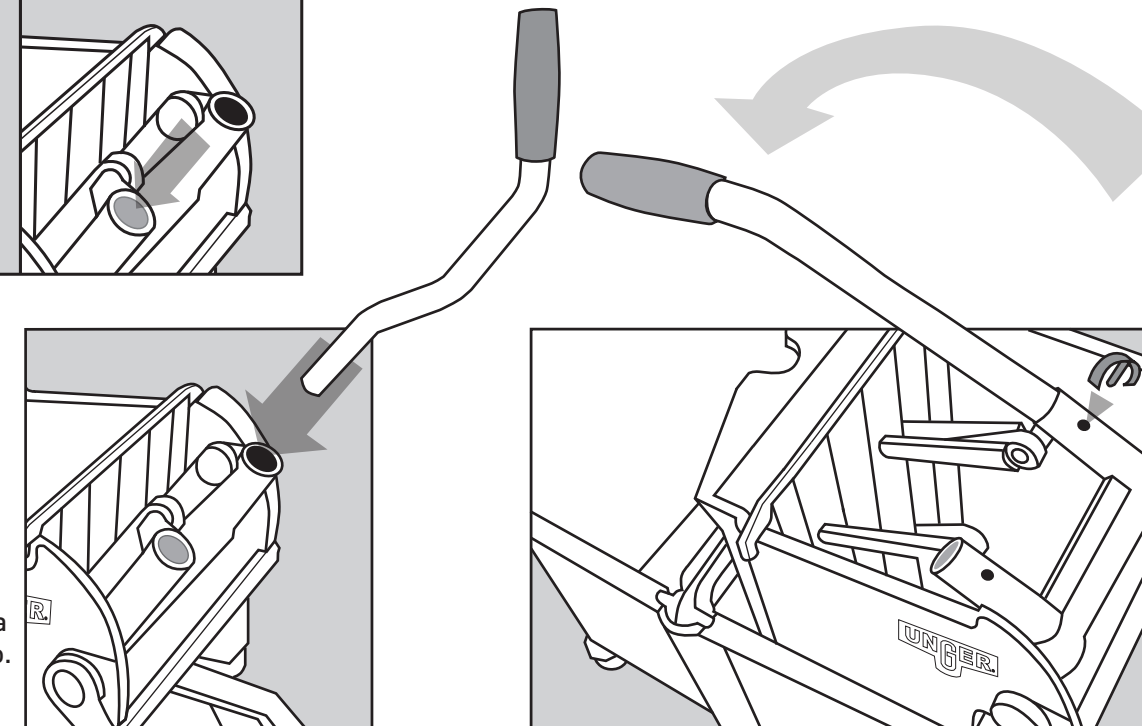

STEP 8: Insert handle into press.

PASO 8: Inserte el mango en la prensa.

STEP 9: Insert clip to secure handle.

PASO 9: Inserte el sujetador para fijar el mango.