

HSM Acknowledgment Form V-Press 610 eco

Specifications

Pressing power	12 tons
Motor	5.1 HP
Voltage / Frequency	3 x 480 V / 60 Hz
Loading aperture W x H	32" x 20"
Bale weight (depending on material)	up to 220 lbs
Bale size	32" x 24" x max. 24"
Cycle time in idle operation (theor.)	22 sec.
Acoustic level	59.6 dB(A)
Press chamber size W x D x H	31.5" x 23.6" x 41.1"
Dimensions of machine* W x D x H	46.9" x 32.1" x 78.0"
Transport dimensions of machine W x D x H	46.9" x 32.1" x 78.0"
Machine weight	1,191 lbs
Strapping	3-fold with polyester tape

*External dimensions of the machine when set up for operation.

Electrical connection

Rated power	5.1 HP
Rated power In	8.30 A
Total fuse	3 x 15 A CC/CF/G/J/T characteristic
Operating voltage	3 x 480 V
Frequency	60 Hz
Plug connection	Twist lock Devices 20 A, 3 Phase 480C/AC, 3-Pole, 4-Wire Grounding
Cable length of power supply	approx. 118"



NEMA L16-20P

- The unloading of the truck and transportation to the installation location will be arranged and paid by the customer (unless other agreements declared in a contract)
- Forklift truck must be available to lift a minimum of 1,430 lbs
- Entrance door dimensions must be a minimum of 6'7"
- Potential floor loading must be adequate for machine (floor loading max. = 51 lbs per ft², bale weight above)
- Ceiling height at operation location must be a minimum of 6'7"
- Please note that all offered prices are based upon the equipment already being offloaded and set into installation location. If additional parts, material, labor or equipment are required additional fees will apply
- Power connection of 480V - 60 Hz is required for operation

HSM®

Great Products, Great People.

Page 1 of 3

HSM Acknowledgment Form V-Press 610 eco

Dimensions and space requirement HSM V-Press 610 eco

Ceiling height min. 6' 7"

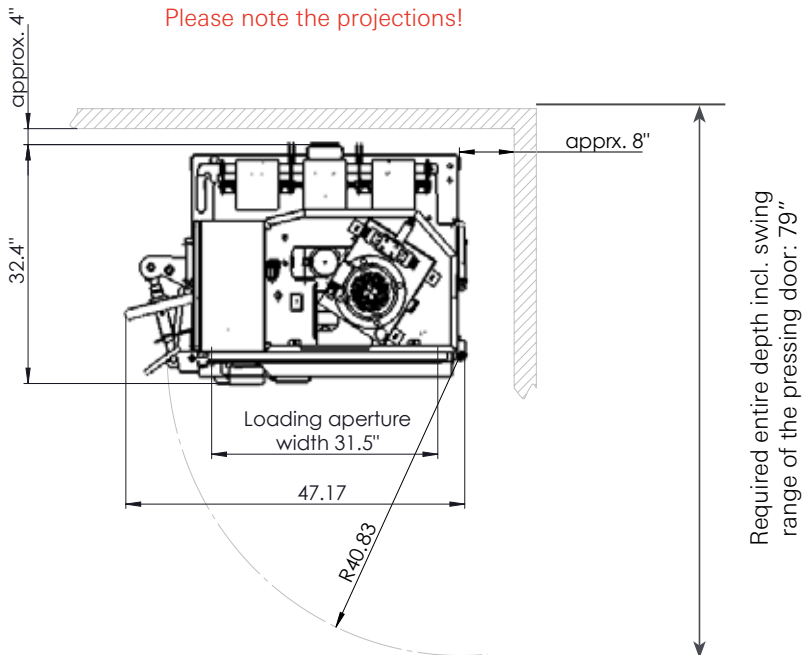
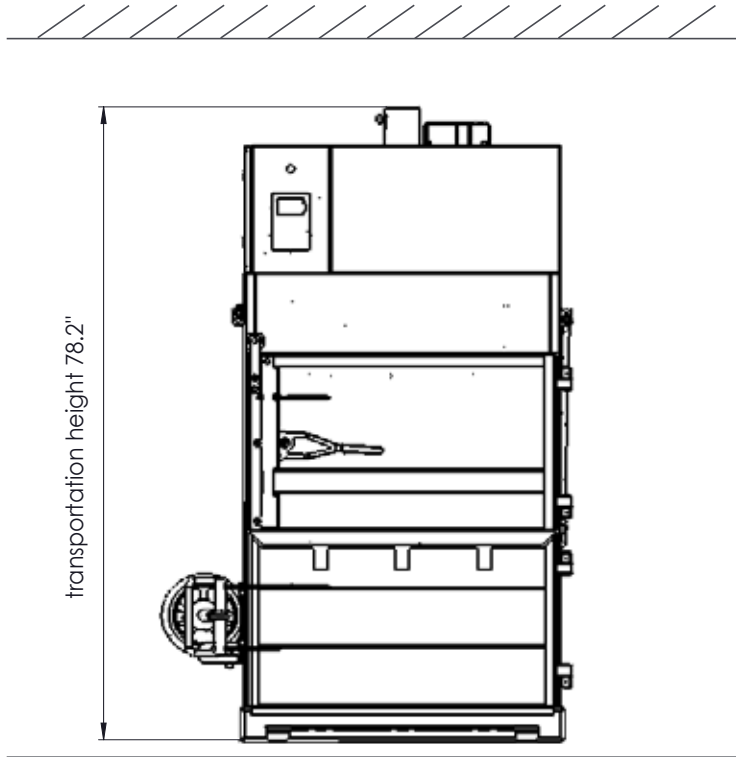

Great Products, Great People.

HSM Acknowledgment Form V-Press 610 eco

_____ (“Buyer”) hereby acknowledges they have purchased
V-Press 610 eco (“Equipment”) from HSM of America, LLC (“HSM”)

Buyer also acknowledges and agrees to all of the terms and conditions described in detail on the HSM website, including the limitation of liability provisions and warranty disclaimers. All of those terms apply provided in connection with the sale of the Equipment. Nothing in this acknowledgment form modifies or amends any of those terms.

Buyer also acknowledges that HSM has provided it with an Operations Manual for the Equipment and that it has received, read and understands the Operations Manual for the Equipment and agrees to adhere to the provisions of that Manual. Buyer further agrees to provide the Manual to each and every user of the Equipment and to ensure that each user is aware of and abides by the proper and safe use of the Equipment. Buyer acknowledges that HSM’s sale of the Equipment was specifically contingent upon Buyer’s obligations and duties with respect to the Operations Manual as set forth herein.

Buyer understands and acknowledges that this machine is being shipped with all necessary warning labels as pictured in the manual. Buyer has read and understands all of the warning labels affixed to the machine and agrees to adhere to those warnings when operating the machine and to make all users of the machine aware of these warnings and insure that the user adheres to those warnings while operating the machine.

Buyer hereby acknowledges they have read, understand and agrees to the requirements outlined in this Acknowledgment Form.

Buyer Signature: _____

Date:



Great Products, Great People.

Page 3 of 3