

12" Wide Standard Lockers – 61000 Series Single Tier Installation Instructions

Thank you for selecting Salsbury's 12" wide standard single tier lockers. We are confident that the quality and construction of the lockers will prove to be a good investment. These instructions are intended to assist you in assembling the lockers. The lockers should then be placed in the installed location and anchored to the floor, wall, or to both. Individual job conditions will dictate the type of anchor fasteners.

Preliminary Note

Please read the complete assembly instructions before attempting to assemble the lockers. Check the materials to be sure that they are correct for the job and that there is no damage.

Be careful to use the correct hardware. Use screw no. 1 all around with screw heads out, except where noted. Lockers should be assembled in groups as indicated in the order of the drawings.

The essential tools required for assembling the lockers are a 5/16" nut driver and 2 small nail punches or drift pins for hole alignment. The lockers should be assembled on a flat level surface and installed in position, anchoring to the floor or wall, as required.

See the illustration to the right to identify the locker parts. Note that the sloping hood, front base, end base, and name plate are optional items and their assembly is covered by a separate installation instruction. Also note that the coat rod is included with the 18" deep models only.

Assembly

1. Fasten a top, bottom, and side to a back. The top and bottom are identical parts and should have the flanges down. Insert a rear leg and fasten. See Illustration 1.

2. Fasten a shelf in position under the top. See Illustration 2.

For a one-wide locker, skip to Step 4.

Parts Identification

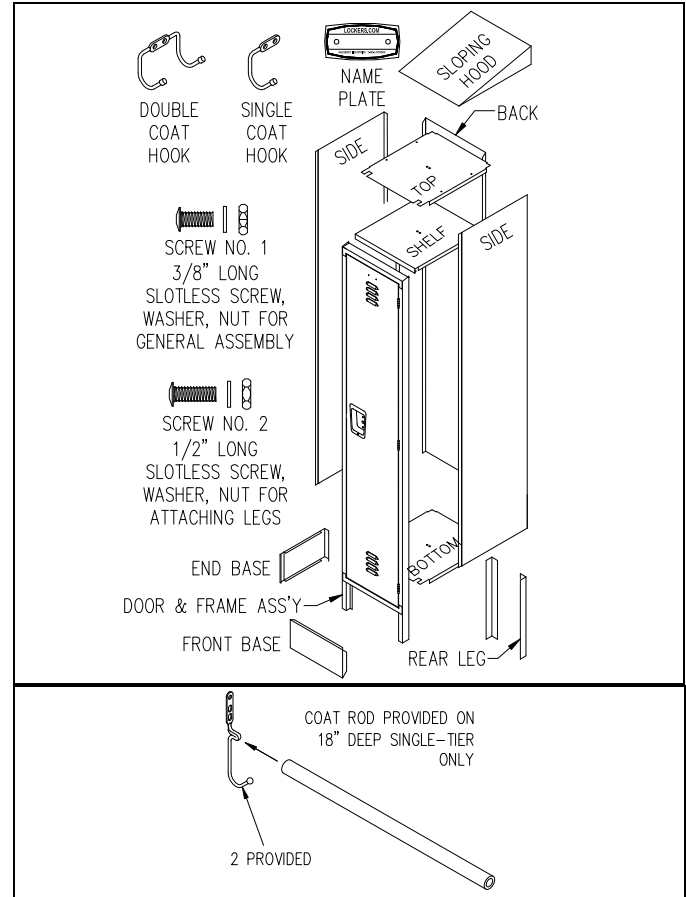

Illustration 1

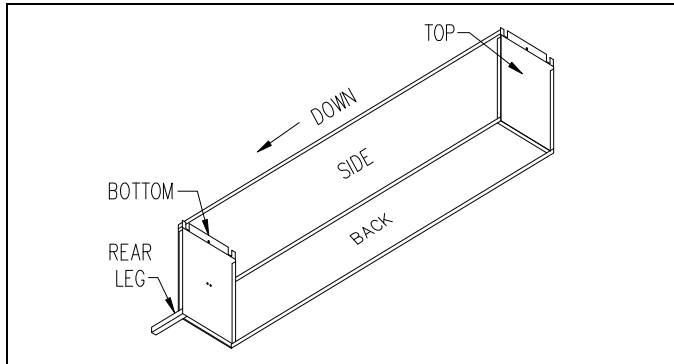
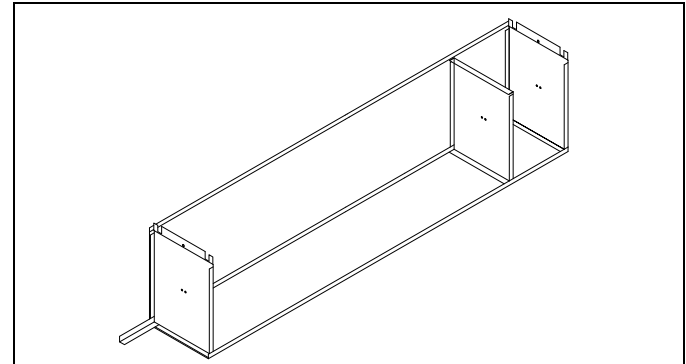

Illustration 2



SALSBUURY INDUSTRIES

18300 Central Avenue, Carson, CA 90746-4008
 Phone: 1-800-562-5377 Int'l Phone: 323-846-6700
 Fax: 1-800-562-5399 Int'l Fax: 323-846-6800
 www.lockers.com engineering@lockers.com

12" Wide Standard Lockers – 61000 Series Single Tier Installation Instructions

Assembly (continued)

3. Position additional sides, backs, tops, bottoms, and shelves and fasten in place. See Illustration 3.

4. Add a last side (flange in) and the other leg. See Illustration 4.

5. Attach the door and frame assemblies, ensuring that the front edges of the sides are inside a frame assembly flange and not between frames. See Illustration 5.

6. Fasten the last door and frame assembly into place, ensuring that they are all fastened correctly. See Illustration 6.

7. Finally, install coat hooks below the top and lock hole fillers into the doors. If there are built-in locks, install locks instead of lock hole fillers.

Illustration 3

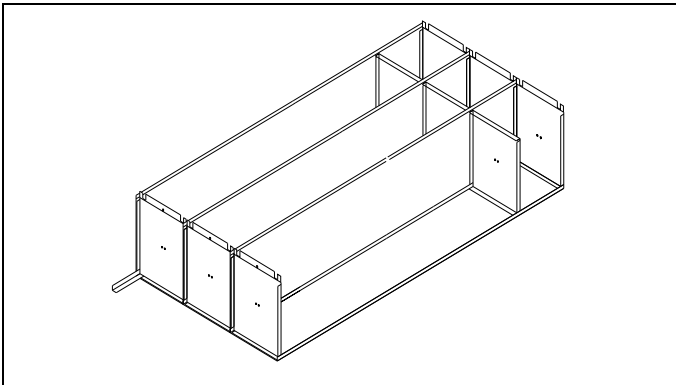

Illustration 5

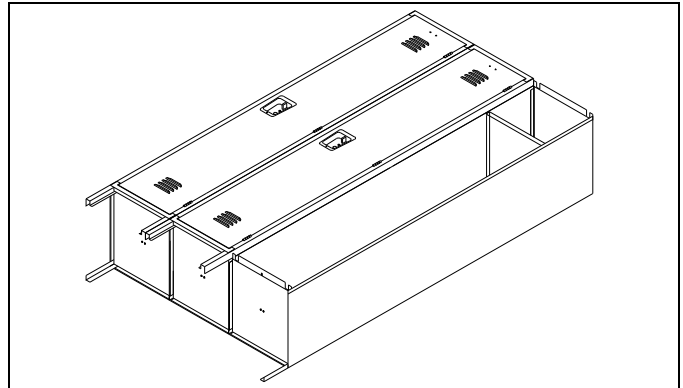

Illustration 4

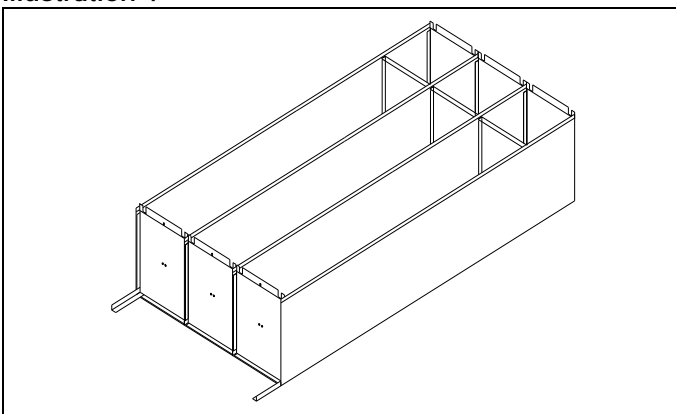
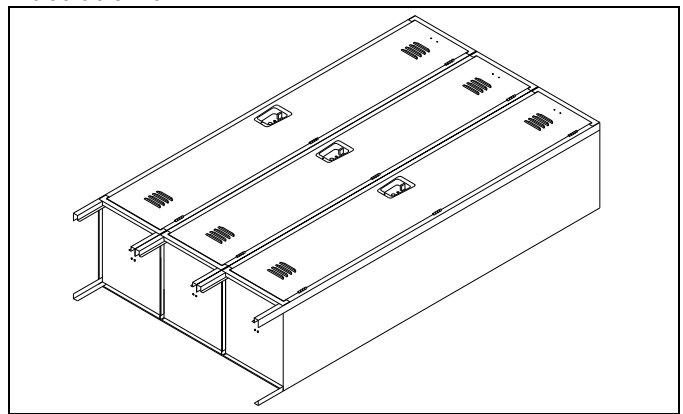
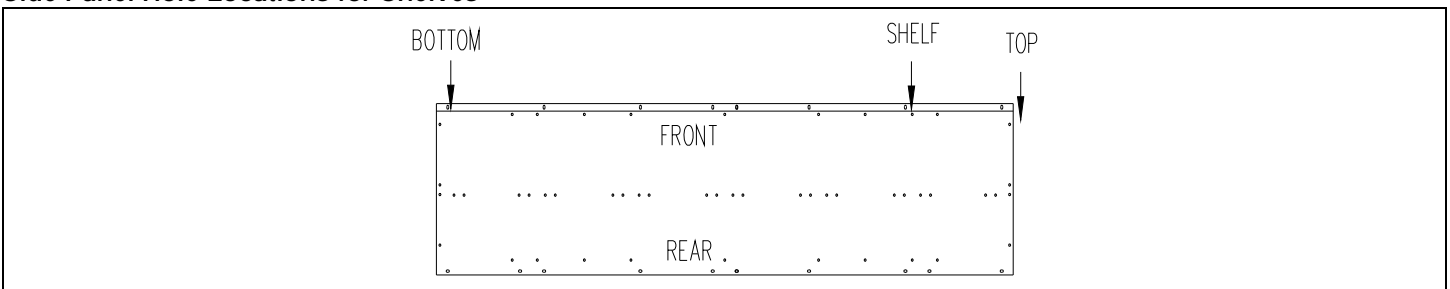

Illustration 6



Side Panel Hole Locations for Shelves



SALSBURY INDUSTRIES

18300 Central Avenue, Carson, CA 90746-4008
 Phone: 1-800-562-5377 Int'l Phone: 323-846-6700
 Fax: 1-800-562-5399 Int'l Fax: 323-846-6800
www.lockers.com engineering@lockers.com

Installation instructions are provided as general guidelines. It is advised that a professional installer be consulted. Salsbury Industries assumes no product assembly or installation liability. Copyright © 2020 Salsbury Industries. All rights reserved. (Rev. 06, 8/4/2010)

12" Wide Standard Lockers – 61000 Series

Installation Instructions - Options

Thank you for selecting Salsbury's 12" wide standard single tier lockers. We are confident that the quality and construction of the lockers will prove to be a good investment. These instructions are intended to assist you in assembling option items into the locker. The name plates, front bases, end bases, and sloping hoods are each separate option items and may or may not be included in your order.

Name Plates

The name plates are installed with #4 slotless screws and nuts.

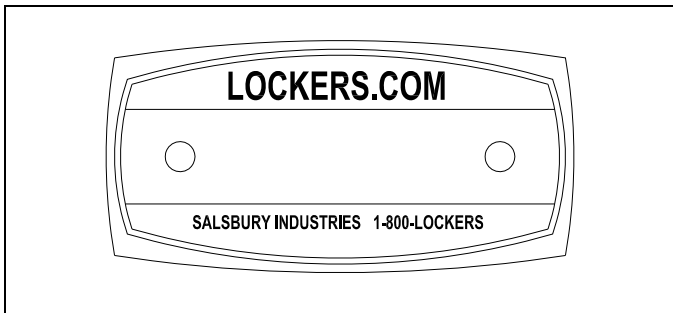

Sloping Hoods

The sloping hoods are assembled and installed on the locker units with #10 x 3/8" slotless screws and nuts. The side plates should be installed inside the flanges of the sloping hood. Only 1 side panel should be assembled between adjacent sloping hoods.

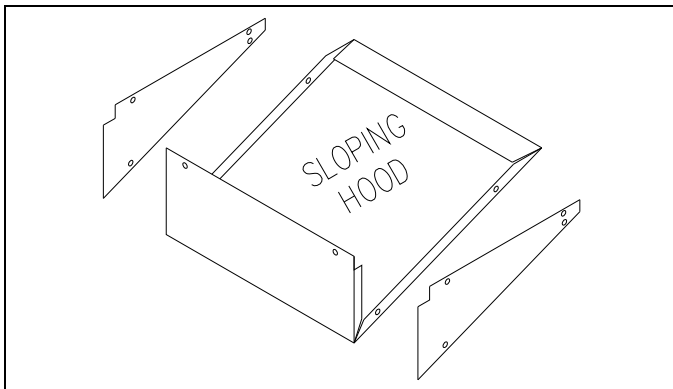

Front Bases and End Bases

The front bases are simply snapped into position between the two legs in the front of the locker unit. No fasteners are required due to the dimples on the front base flanges.

The end bases are installed and fastened with 2 screws and nuts such that the end base front edge is inserted inside the locker front leg with the end base rear flanges wrapped around the outside of the locker rear leg.

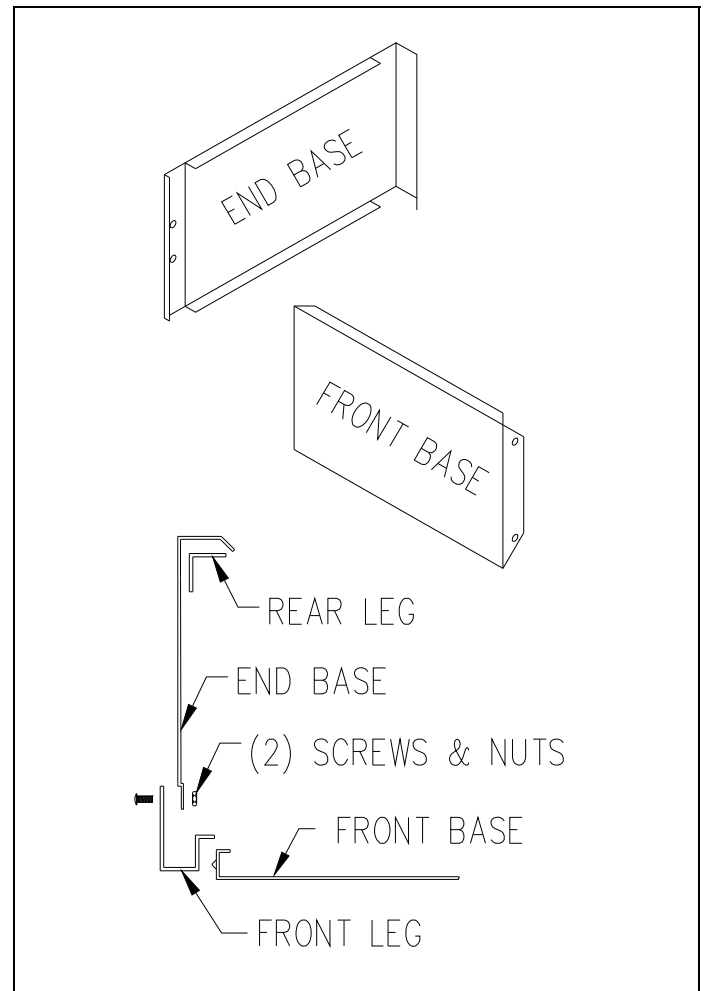

SALSBURY INDUSTRIES

18300 Central Avenue, Carson, CA 90746-4008
Phone: 1-800-562-5377 Int'l Phone: 323-846-6700
Fax: 1-800-562-5399 Int'l Fax: 323-846-6800
www.lockers.com engineering@lockers.com