



WORLDWIDE ELECTRIC MOTOR DATA SHEET



ODP40-12-364T

HORSEPOWER	40		
RPM / POLES	1200 / 6		
VOLTAGE / PHASE	208 - 230 / 460 V / 3		
FRAME	364T		
ENCLOSURE / DEGREE OF PROTECTION	ODP / IP23		
FREQUENCY	60 HZ Suitable For 50 HZ Operation With 1.0 SF		
FULL LOAD SPEED	1184 RPM		
SERVICE FACTOR	1.15 SF 60HZ / 1.0 SF at 50HZ		
INSULATION CLASS	F		
FULL LOAD AMPS; 230 / 460	93.4 / 46.7 A		
LOCKED ROTOR AMPS (STARTING); 230 / 460	571.6 / 285.8 A		
NO LOAD CURRENT	33.0 / 16.5 A		
NEMA CODE LETTER	G		
EFFICIENCY / POWER FACTOR	<u>LOAD</u>	<u>EFF.</u>	<u>P.F.</u>
	100%	94.1%	0.85
	75%	94.9%	0.82
	50%	94.7%	0.74
DUTY CYCLE	S1 / Continuous		
TORQUE	<u>FULL LOAD</u>	<u>LRT</u>	<u>BDT</u>
	178.3 lb.ft.	243%	350%
SLIP	1.362%		
NEMA DESIGN	B		
NUMBER OF STARTS (Hot / Cold)	2 Hot / 3 Cold		
MAX. AMBIENT TEMPERATURE	40° C		
MAX. ELEVATION	3300 Ft. Above Sea Level		
TEMPERATURE RISE (At Full Load)	80° C		
DE BEARING	6314		
ODE BEARING	6214		
GREASE TYPE	Mobil Polyrex EM		
MOUNTING	F1 / F2 Suitable		
ROTATION	Bi-Directional		
APPROXIMATE WEIGHT	706 lbs.		
AREA CLASSIFICATION	Non-Hazardous		
INVERTER RATING	10:1 CT / 20:1 VT PWM Type		
SPECIFICATION - In Accordance With	NEMA, UR		



JULY 22, 2020



WORLDWIDE ELECTRIC MOTOR DRAWING

ODP-364T

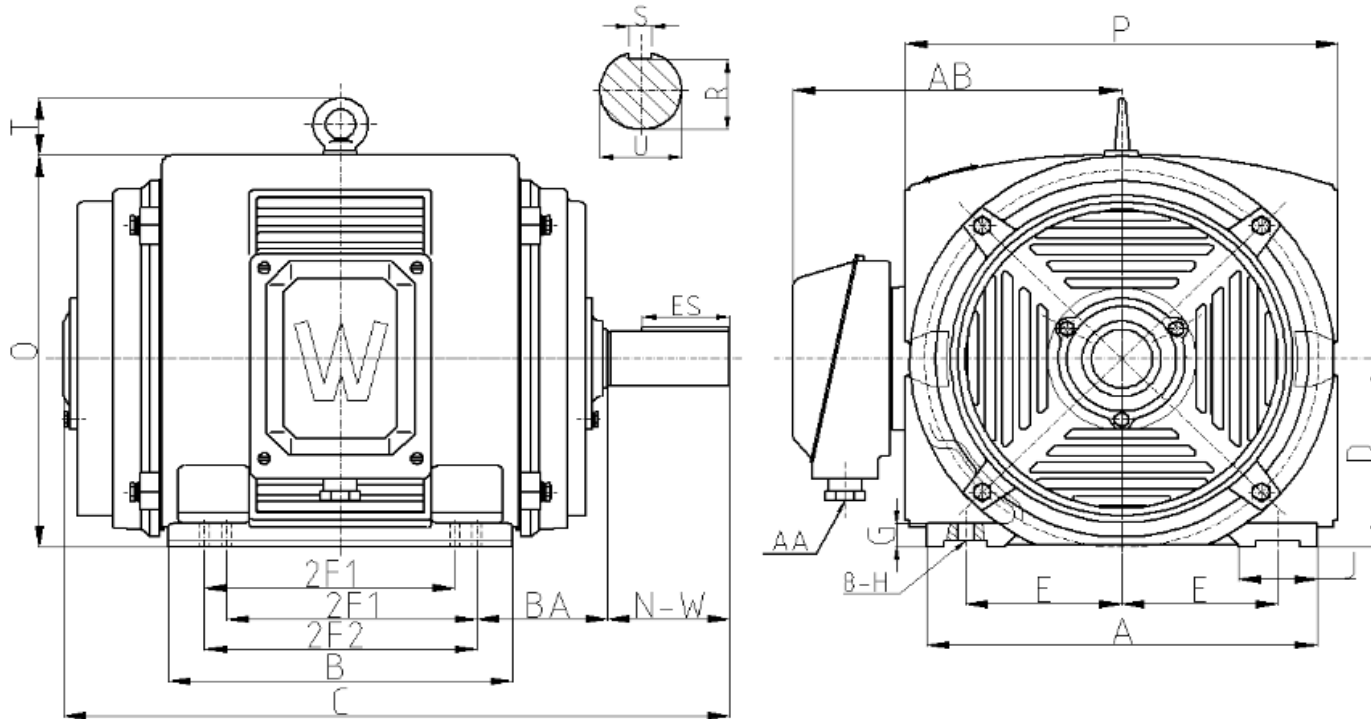

ALL DIMENSIONS IN INCHES

MOUNTING										
E	2F1	2F2	H	BA	A	B	C	D	G	
7	11.25	12.25	0.66	5.88	17.6	15.5	30.9	9	1.1	

KEYSET	KEY										
	ES	S	U	N-W	P	AB	AA	O	J	T	
2.021	4.28	0.625	2.375	5.88	19.5	14.8	3	18.5	3.543	2.7	

REVISED - 09/24/2019