



WORLDWIDE ELECTRIC MOTOR DATA SHEET



ODP34-36-56CB

HORSEPOWER	0.75		
RPM / POLES	3600 / 2		
VOLTAGE / PHASE	208 - 230 / 460 V / 3		
FRAME	56CB		
ENCLOSURE / DEGREE OF PROTECTION	ODP / IP23		
FREQUENCY	60 HZ Suitable For 50 HZ Operation With 1.0 SF		
FULL LOAD SPEED	3420RPM		
SERVICE FACTOR	1.15 SF 60HZ / 1.0 SF at 50HZ		
INSULATION CLASS	F		
FULL LOAD AMPS; 230 / 460	1.96 / 0.98 A		
LOCKED ROTOR AMPS (STARTING); 230 / 460	14.26 / 7.13 A		
NO LOAD CURRENT	0.78 / 0.39 A		
NEMA CODE LETTER	J		
EFFICIENCY / POWER FACTOR	<u>LOAD</u>	<u>EFF.</u>	<u>P.F.</u>
	100%	76.8%	0.87
	75%	80.5%	0.83
	50%	77.5%	0.74
DUTY CYCLE	S1 / Continuous		
TORQUE	<u>FULL LOAD</u>	<u>LRT</u>	<u>BDT</u>
	1.13 lb.ft.	318%	307%
SLIP	5.001%		
NEMA DESIGN	B		
NUMBER OF STARTS (Hot / Cold)	2 Hot / 3 Cold		
MAX. AMBIENT TEMPERATURE	40° C		
MAX. ELEVATION	3300 Ft. Above Sea Level		
TEMPERATURE RISE (At Full Load)	80° C		
DE BEARING	6203ZZ		
ODE BEARING	6203ZZ		
GREASE TYPE	NS7 ENS		
MOUNTING	F1		
ROTATION	Bi-Directional		
APPROXIMATE WEIGHT	26.5 lbs.		
AREA CLASSIFICATION	Non-Hazardous		
INVERTER RATING	10:1 CT / 20:1 VT PWM Type		
SPECIFICATION - In Accordance With	NEMA, UR		

ODP-56C

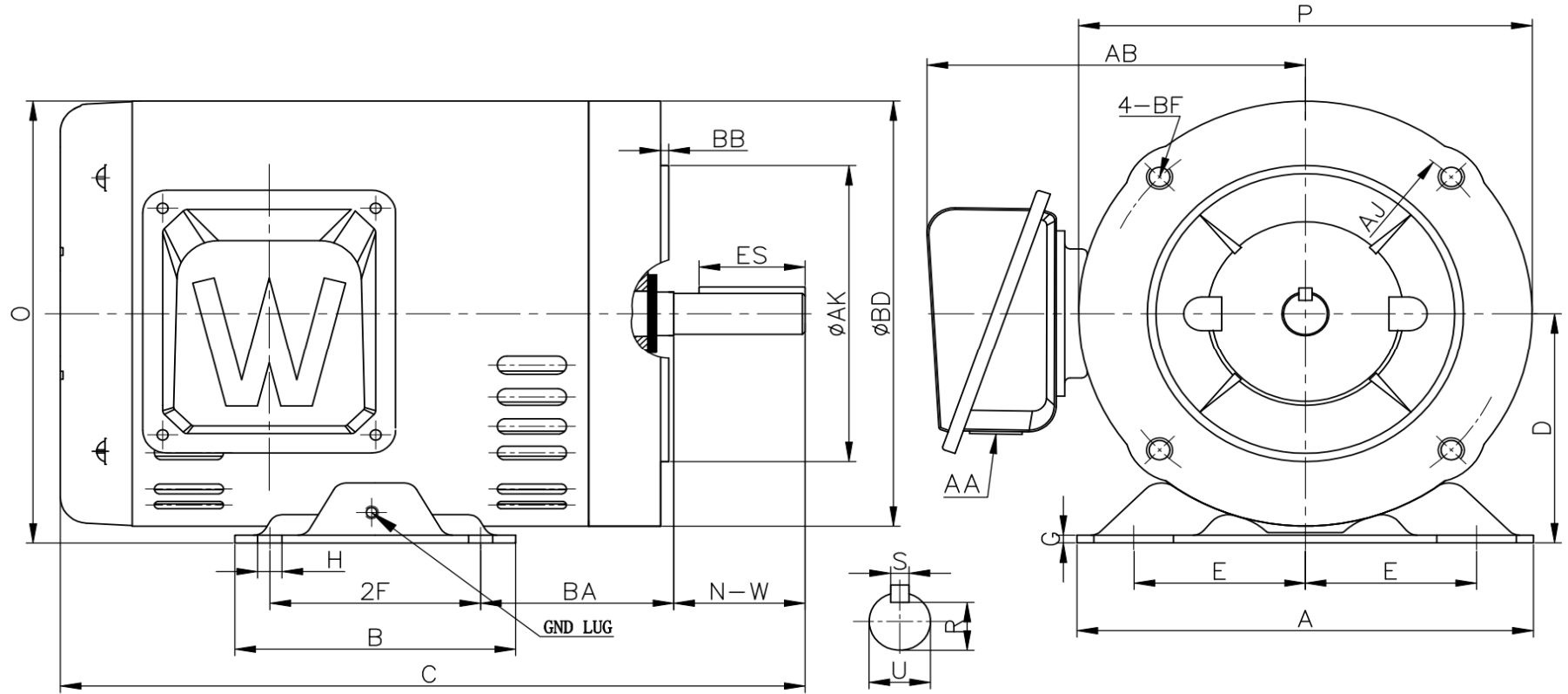

DIMENSIONS IN INCHES

MOUNTING				A	B	C	D	G	P	O	AB	AA	GND LUG
E	2F	H	BA										
2.44	3	0.34	2.75	6.49	3.99	10.6	3.5	0.118	6.5	6.71	5.7	0.88	M5*P0.8

SHAFT AND KEYWAY				
S	ES	R	N-W	U
0.188	1.41	0.517	1.88	0.625

FLANGE				
AK	BD	AJ	BF	BB
4.5	6.5	5.875	(4) 3/8-16 UNC	0.12