



# WORLDWIDE ELECTRIC MOTOR DATA SHEET



## ODP2-18-145T-F2

HORSEPOWER	2		
RPM / POLES	1800 / 4		
VOLTAGE / PHASE	208 - 230 / 460 V / 3		
FRAME	145T		
ENCLOSURE / DEGREE OF PROTECTION	ODP / IP23		
FREQUENCY	60 HZ Suitable For 50 HZ Operation With 1.0 SF		
FULL LOAD SPEED	1744 RPM		
SERVICE FACTOR	1.15 SF 60HZ / 1.0 SF at 50HZ		
INSULATION CLASS	F		
FULL LOAD AMPS; 230 / 460	5.4 / 2.7 A		
LOCKED ROTOR AMPS (STARTING); 230 / 460	47.24 / 23.62 A		
NO LOAD CURRENT	2.96 / 1.48 A		
NEMA CODE LETTER	L		
EFFICIENCY / POWER FACTOR	<u>LOAD</u>	<u>EFF.</u>	<u>P.F.</u>
	100%	86.5%	0.79
	75%	87.6%	0.71
	50%	86.0%	0.58
DUTY CYCLE	S1 / Continuous		
TORQUE	<u>FULL LOAD</u>	<u>LRT</u>	<u>BDT</u>
	6.06lb.ft.	349.0%	387.0%
SLIP	3.123%		
NEMA DESIGN	B		
NUMBER OF STARTS (Hot / Cold)	2 Hot / 3 Cold		
MAX. AMBIENT TEMPERATURE	40° C		
MAX. ELEVATION	3300 Ft. Above Sea Level		
TEMPERATURE RISE (At Full Load)	80° C		
DE BEARING	6205ZZ		
ODE BEARING	6204ZZ		
GREASE TYPE	NS7 ENS		
MOUNTING	F2		
ROTATION	Bi-Directional		
APPROXIMATE WEIGHT	38.6 lbs.		
AREA CLASSIFICATION	Non-Hazardous		
INVERTER RATING	10:1 CT / 20:1 VT PWM Type		
SPECIFICATION - In Accordance With	NEMA, UR		



CC067A



MARCH 14, 2017



# WORLDWIDE ELECTRIC MOTOR DRAWING

## ODP-145T-F2

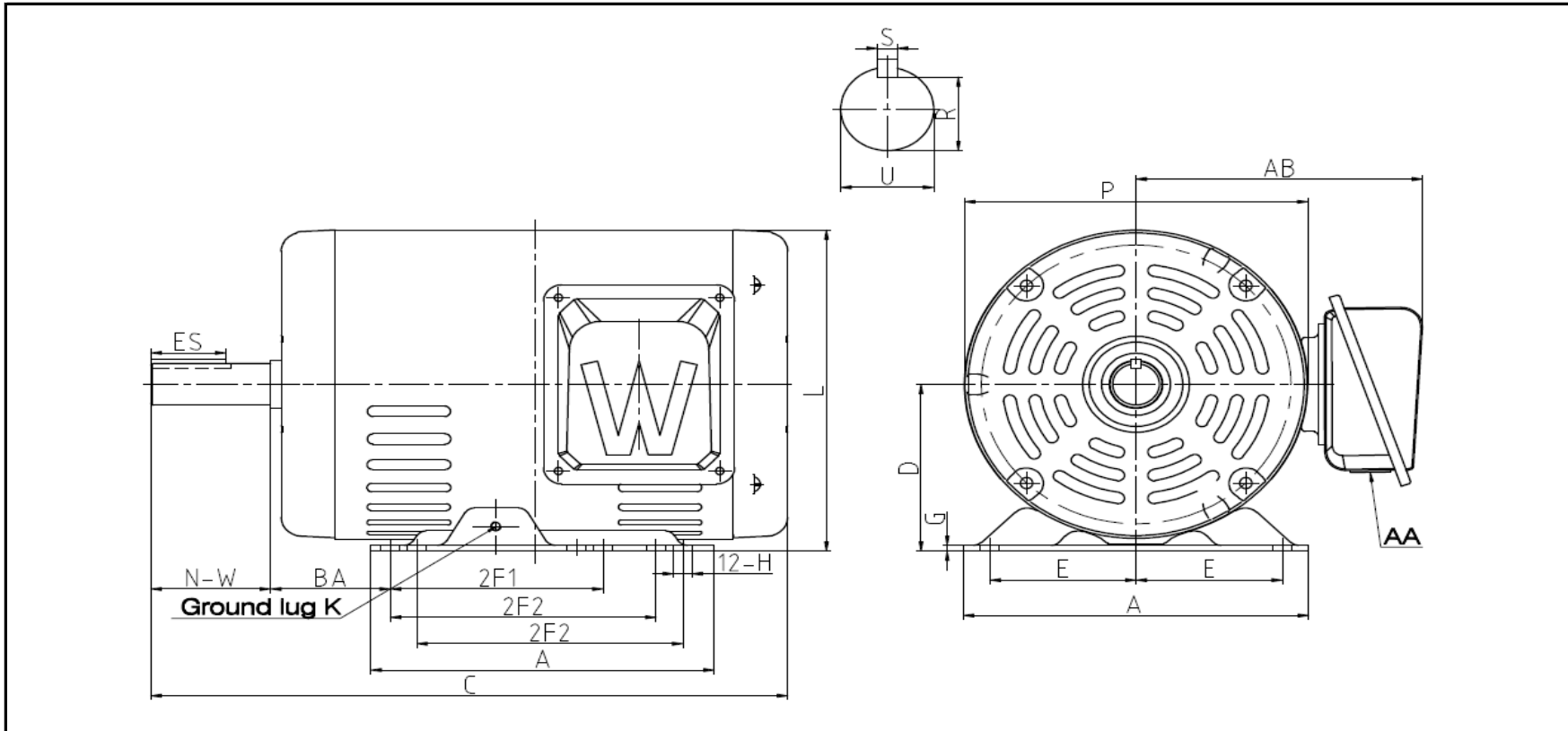

**DIMENSIONS - INCHES**

MOUNTING											
E	2F1	2F2	H	BA	A	B	C	D	G	K	
2.75	4	5	0.34	2.25	6.5	6.5	11.974	3.5	0.118	M5	

KEYSET	KEY							
R	ES	S	U	N-W	P	AB	AA	L
0.771	1.41	0.188	0.875	2.25	6.4	5.384	1.09	6.4

REVISED - 11/14/18