

BACK AND END STOPS

ASSEMBLY INSTRUCTION

Model # 254714 (48x30)

254716 (48x36)





254718 (60x30)

254720 (60x36)

254722 (72x30)

254724 (72x36)

CONTENTS

REF.	QTY.	DESCRIPTION
1	2	END STOP
2	1	BACK STOP
H1	20	1/4 Split Washer 
H2	20	M6 x 1.0 x .625 Lg. Phillips Pan Head Screw 
H3	20	M6 x 1.0 Hex Nut 
	20	#14 Slotted Hex Head Wood Screw 

Note: Model # and the type of Tops (wood or steel) determine hardware type and quantity.

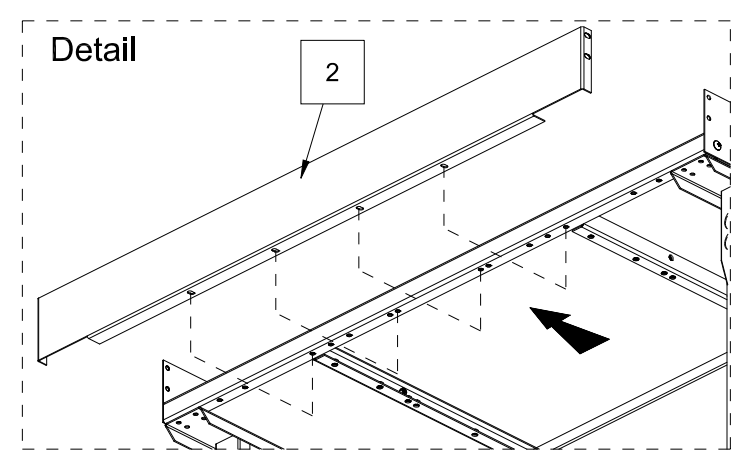
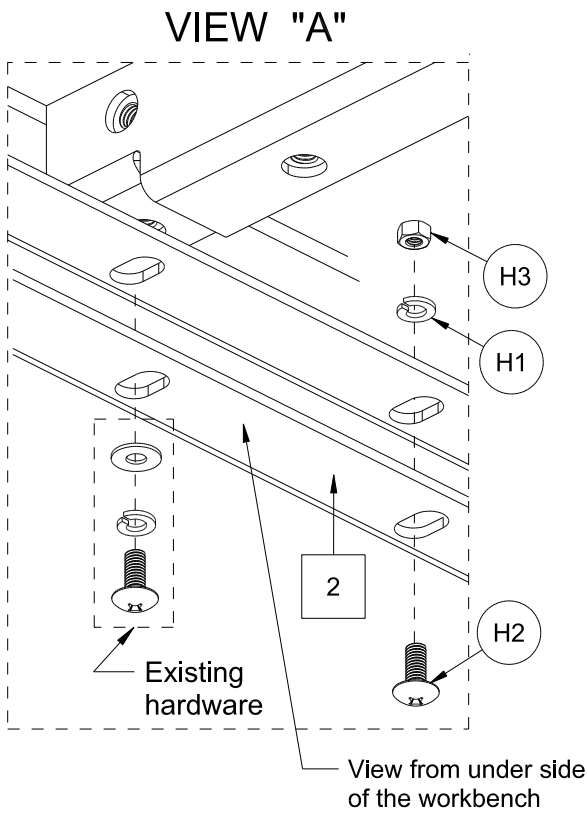
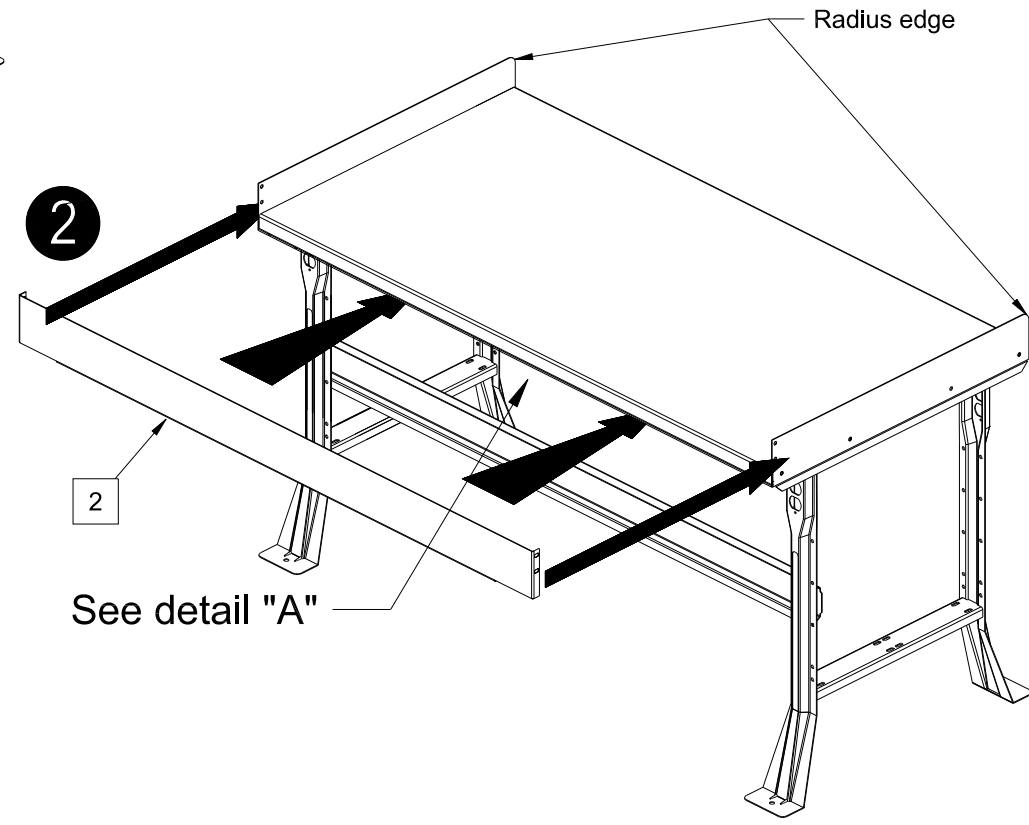
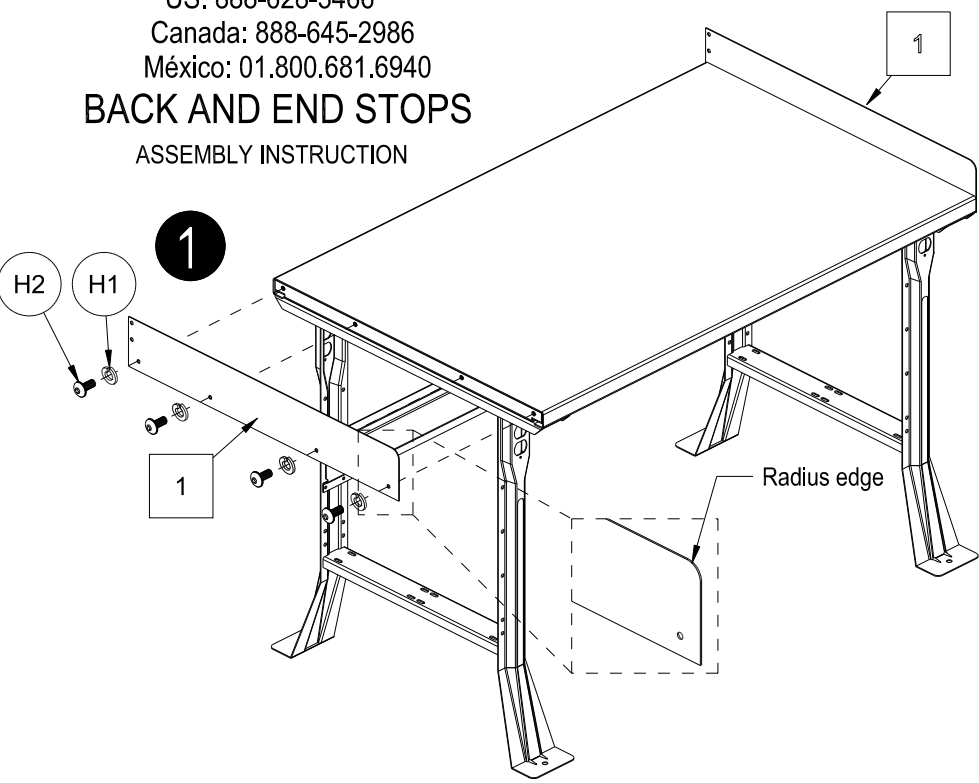

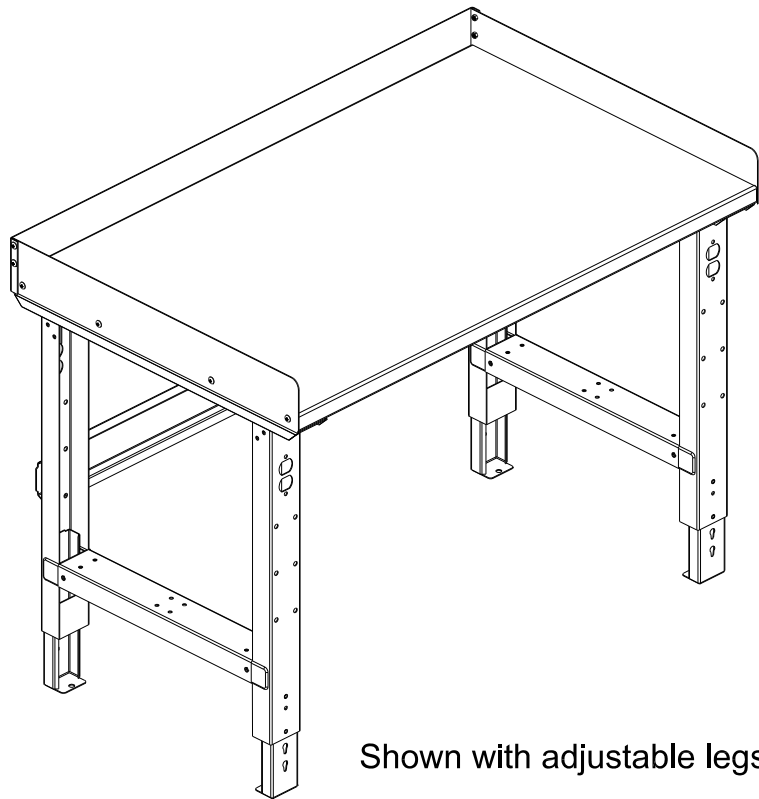
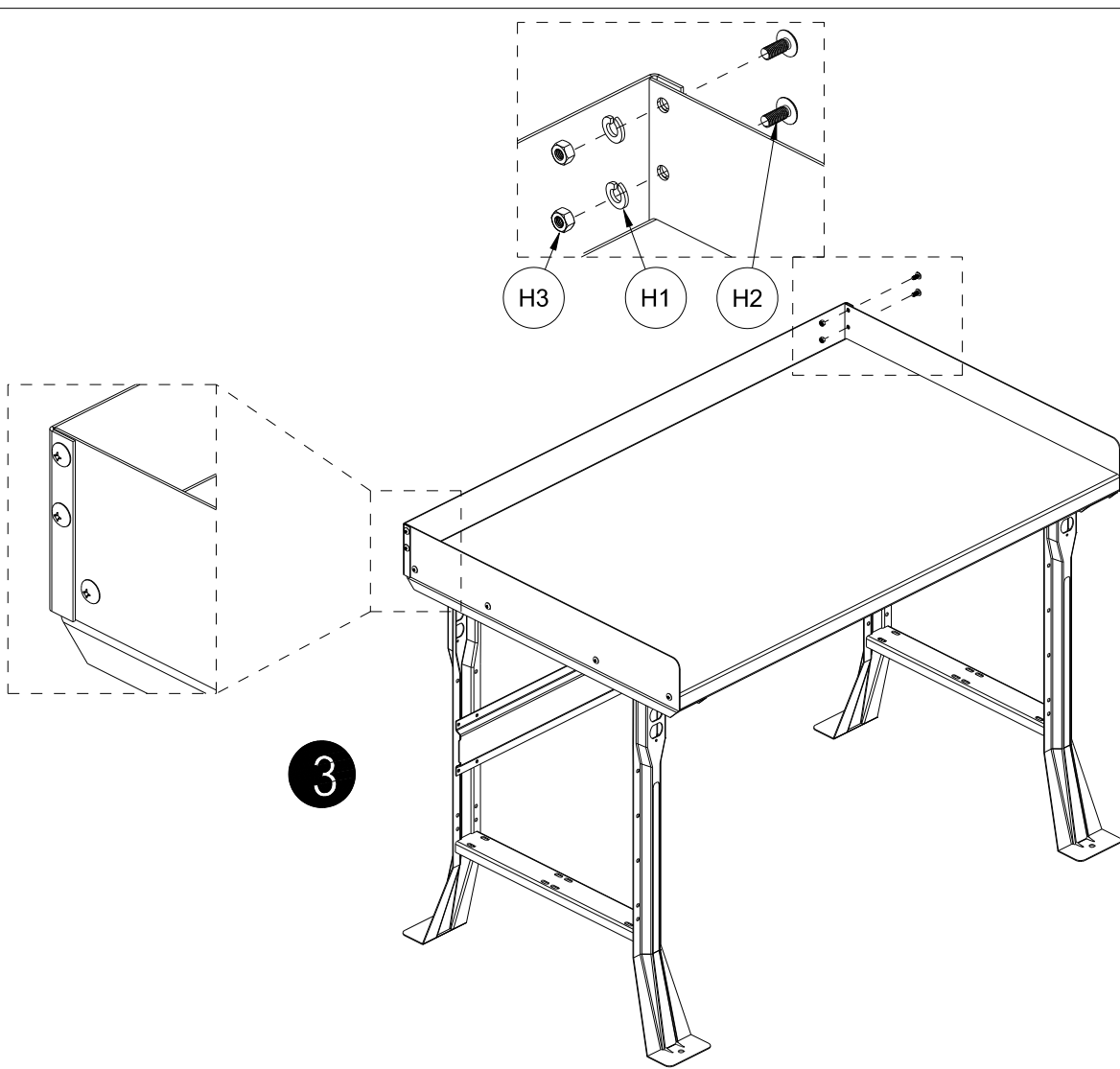

Shown with adjustable legs