

CONTENTS

REF.	QTY.	DESCRIPTION
1	3	LEG
2	2	STRINGER
3	1	TOP
H1	12	M6 NYLON LOCK NUT
H2	12	M6 x .625 PHILLIPS PAN HEAD SCREW
H3	18	10mm hex washer head screw
	1	7/32 DRILL BIT
H4	1	5/32 allen key



www.globalindustrial.com

1-800-645-2986

FLARED FIXED LEG WORKBENCH

Model 183436 183447 183448

601428 601430

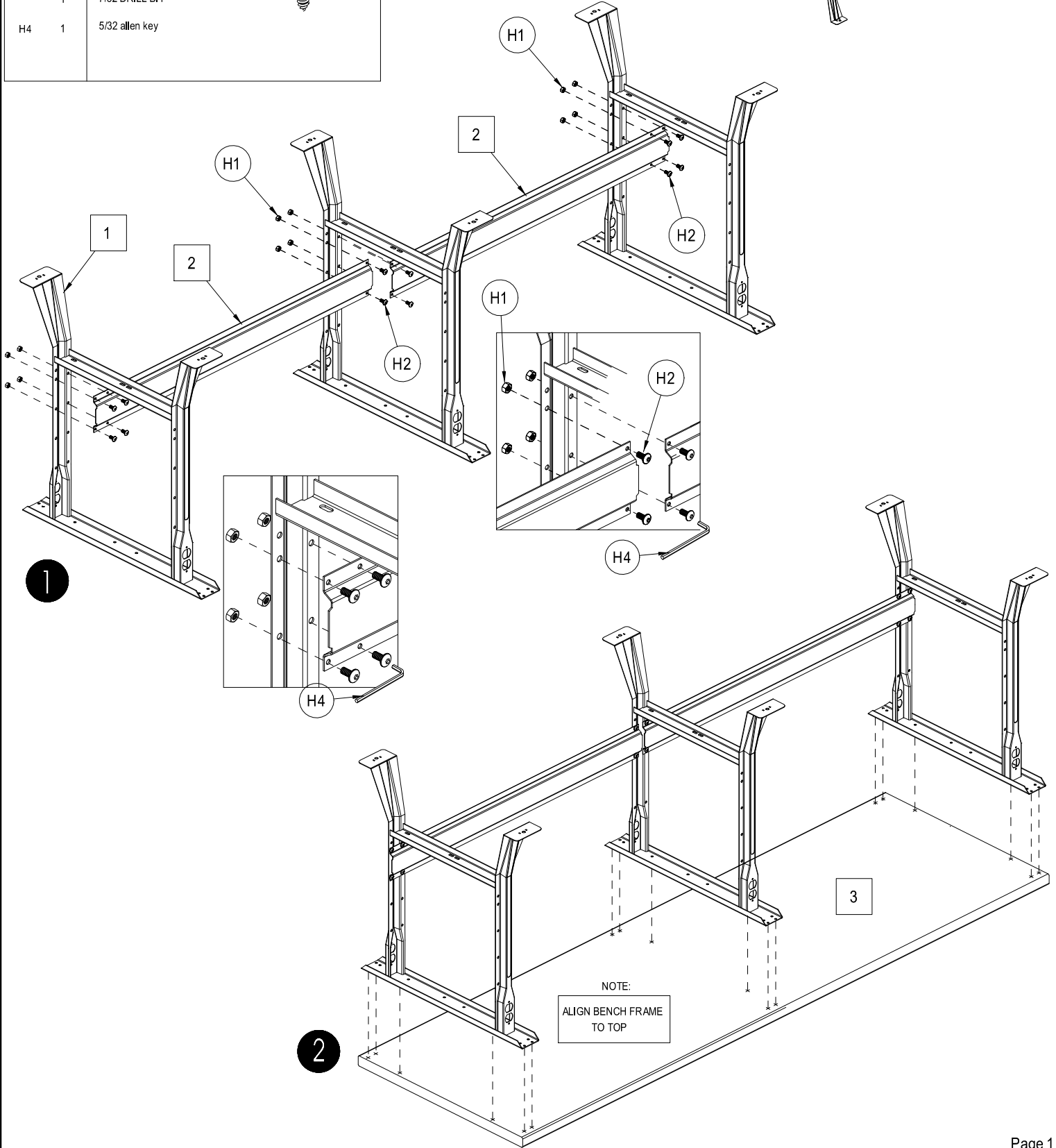
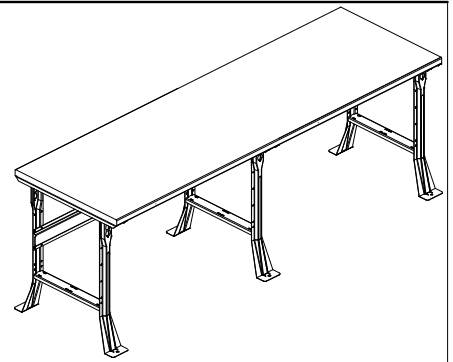

3

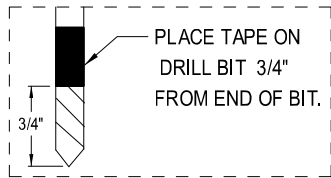
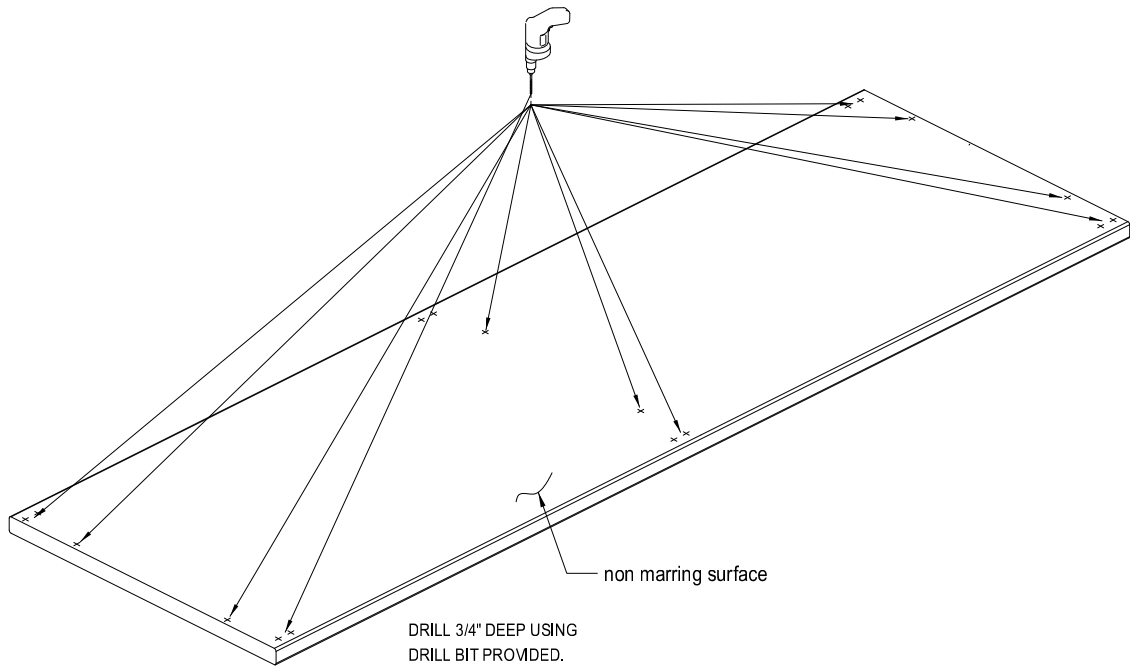

4

