

User's manual
Manual del usuario
Manuel de l'utilisateur

Customer Service
US: 1-800-645-2986

Servicio de atención al Cliente
US: 1-800-645-2986

Service à la clientèle
Canada: 888-645-2986

Wall Mounted Water Bottle Refilling Station



Model 761218



System 761218 certified by IAPMO R&T against to NSF/ANSI/CAN 372 for lead free compliance



Read this manual thoroughly prior to installation, operation or maintenance. Keep these instructions in a safe location for future reference. For questions, visit globalindustrial.com or contact Customer Service at 1-800-645-2982.

⚠ WARNING

- Keep compressor in upright position for 24 hours before water connections and initial power-on. Failure to do so will void warranty.
- For indoor commercial use only.
- All installation work must be performed by authorized service personnel.
- Two or more people are recommended to lift and install the unit.
- To avoid the risk of property damage and/or personal injury, mount the unit to a flat finished wall surface with adequate support.
- Check local codes for plumbing requirements prior to installation.
- Prior to initial installation, install a shut-off valve (not included) from the water supply.
- Thoroughly flush all water lines and fittings of all foreign matter before connecting to the cooler. Failure to do so will void warranty.
- Check for any leaks before initial operation.
- DO NOT attempt to repair or replace any part of your appliance unless it is specifically recommended in this manual. All other services should be referred to a qualified technician.

- For use with clean, clear potable drinking water only.
- Shut-off water supply during installation to reduce risk of water damage.
- Ensure proper ventilation by allowing appropriate clearance of housing louvers to the wall on each side of the cooler, as specified in rough-in guide.
- NEVER wire the compressor directly to an electrical supply.
- DO NOT allow children to play with the appliance.
- Interior of unit may contain sharp edges. Wear gloves when handling or servicing unit.
- Failure to follow installation instructions will void warranty.

Note: These fixtures are intended for indoor commercial use only. Do not expose to freezing temperatures. The grounding of electrical equipment to water lines is a common procedure. This grounding may be in the building or occur away from the building. This grounding can cause electric feedback into the water cooler creating an electrolysis which creates a metallic taste or causes the water metal content to increase. Connect to water supply using non-conductive materials.

Wall Mounted Water Bottle Refilling Station

Risk of Electrical Shock

- Disconnect power before servicing unit.
- Electric supply must be identical in voltage, cycle and phase to those specified in the specifications below. Unit must be plugged into a GFCI outlet.
- Always pull the plug – not the cord – when disconnecting from the outlet
- DO NOT use if the power cord is worn or damaged. Power cords should only be replaced by qualified service technicians using genuine replacement parts.
- Check local codes for electrical requirements.
- DO NOT disassemble or modify unit.
- Use Global Industrial filter only- Model 670336

Voltage/Hertz	115V/60Hz
*Chilling Capacity	5.3 GPH
Full-Load Amps	1.9 Amps
Rated Watts	185 W
Filter Capacity	4750 or 3600 Gallons
Quick-Fill Rate	1.0 GPM
Water Flow	Laminar
Overall Dimensions	18 ¹ / ₈ "W x 16"D x 37 ¹³ / ₁₆ "H
Certification	UL399 and CAN/CSA 22.2 No. 120 ADA Compliant
	System 761218 certified by IAPMO R&T against NSF/ANSI/CAN372 for lead free compliance
	Filter 670336 certified by NSF to NSF/ANSI 42&53

* At 46° - 54° (F) against ambient air temperature of 77° (F)

Package Contents:

Box 1 - 761213 Top Assembly for Bottle Filler

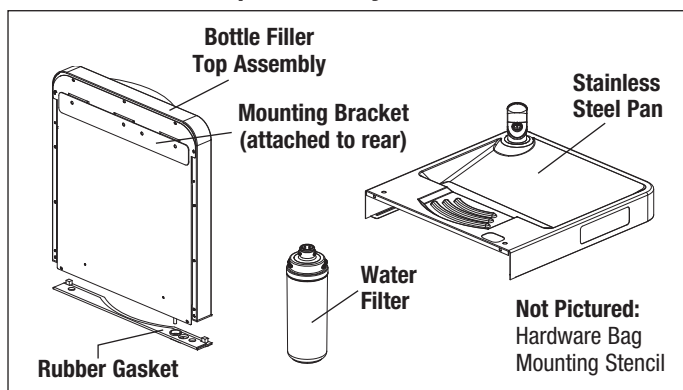

Box 2 - 761212 Cooling System for Water Fountain

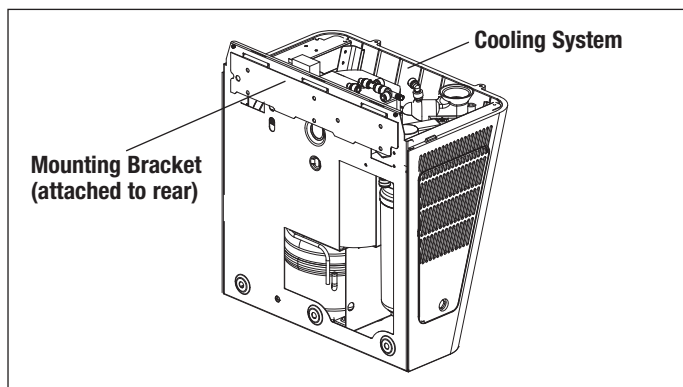

Note:

- Prior to installation, consult with local, state, and federal codes for proper mounting height.
 - All installation and service should only be performed by authorized personnel.
 - Dimensions shown below comply with ADA requirements at time of printing.
 - Allow 4" minimum clearance on both sides to allow for proper ventilation through cabinet louvers.
 - Thoroughly flush all water lines and fittings of all foreign matter before connecting to the Cooling System.
- Failure to do so will void warranty.**

Required Tools:

1. Safety Glasses
2. Safety Gloves
3. Electric Drill
4. Phillips Head Screwdriver
5. Flathead Screwdriver
6. Tape Measure
7. Pencil
8. Level Device
9. (11) 75-lb. Capacity Flat Head Wall Anchors (appropriate for your wall type)
10. (11) Flat Head Anchor Screws

⚠ WARNING

- Review manual thoroughly and verify rough-ins before installation. Keep these instructions in a safe location for future reference.
- Keep compressor in upright position for 24 hours before water connections and initial power-on. **Failure to do so will void warranty.**
- It is recommended to assemble this product on a tabletop or bench.
- Fixture must be mounted to a flat finished industry standard wall surface. The wall surface must have adequate support to secure the fixture, with the addition of wall anchors (not included) if required.
- All receptacles must be wired to a GFCI protected circuit. Fixture must be earth grounded per National Electric Code (NEC).
- Inspect fixture and all parts for damage.

Assembly Instructions

Wall Mounted Water Bottle Refilling Station

Model 761218

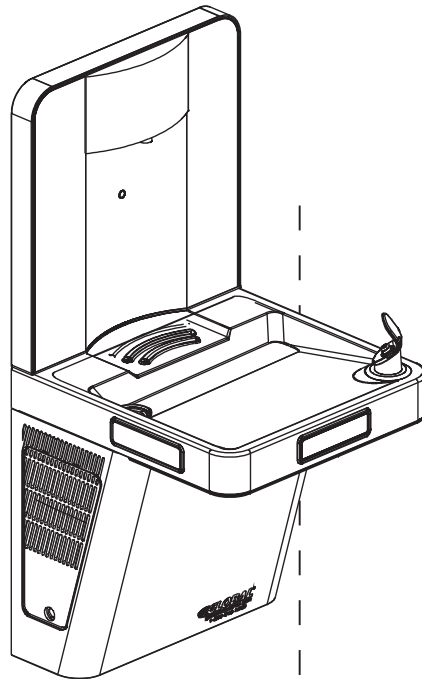

CONTENTS		
Ref.	Qty.	Description
1	1	Cooling System
2	1	Lower Cover
3	1	Bottom Mounting Bracket
4	1	Bottle Filler Top Assembly
5	1	Back Plate
6	1	Top Mounting Bracket
7	1	Gasket
8	1	Stainless Steel Pan
9	1	Water Filter
10	1	Filter Access Door
H1	4	M4 x 8mm Lg. Torx an Head Anti-Theft Screw 
H2	1	Torx Key 
H3	2	M6 x 20mm Lg. Phillips Truss Head Screw 
H4	2	ST4.2x 12. Phillips Pan Head Screw 
H5	6	M4 x0 .7x 8mm Lg. phillips Flat Head Screw 
H6	2	Filter Access Door Key 

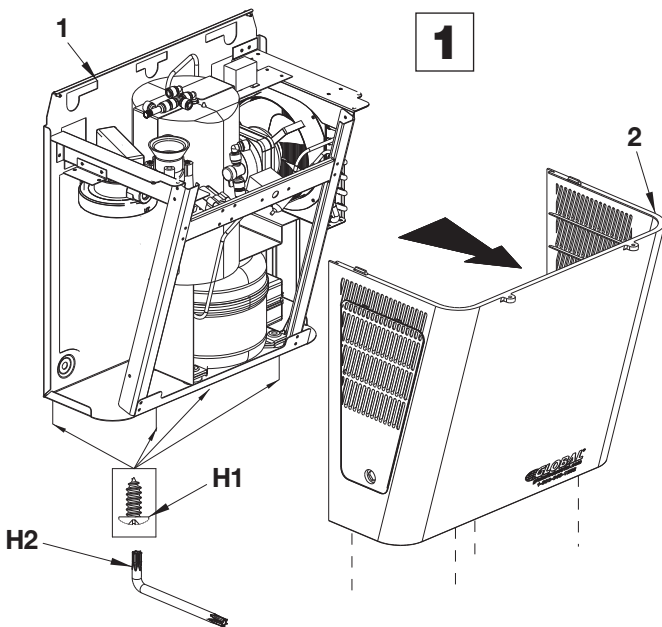

Remove Lower Cover

Using the Anti-Theft Screw Star Key, remove the (4) screws at the bottom of the Lower Cover. Set Lower Cover aside and save screws for reinstallation.

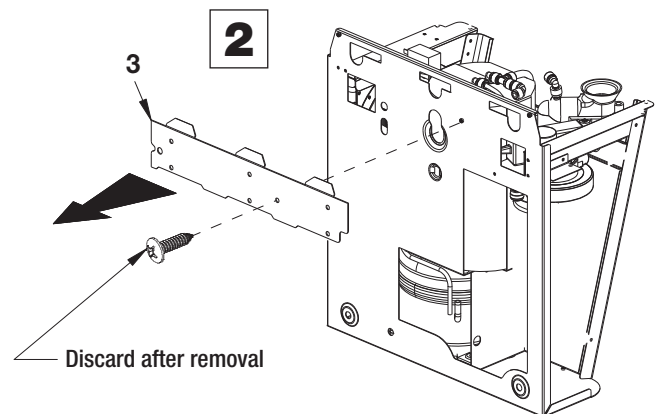

Remove mounting bracket

Using a Phillips head screwdriver, remove the Mount Bracket from the rear of the Cooling System by removing (1) screw. Set bracket aside and save screws for reinstallation.

Wall Mounted Water Bottle Refilling Station

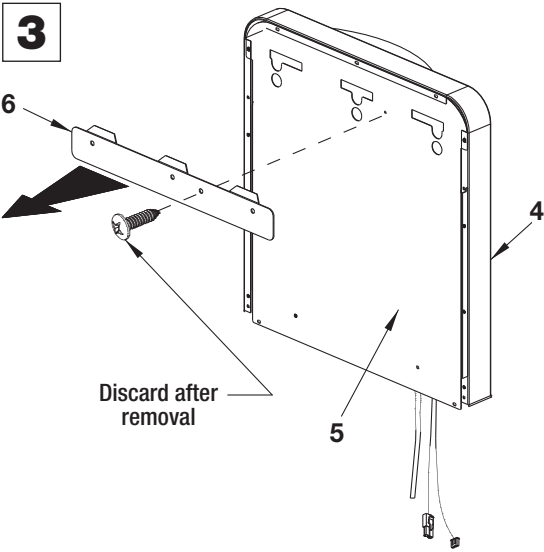

Remove top mounting bracket

Using a Phillips head screwdriver, remove the Top Wall Mount Bracket fastened to the rear of the Bottle Filler Top Assembly by removing (1) screw. Set bracket aside and save screws for reinstallation.

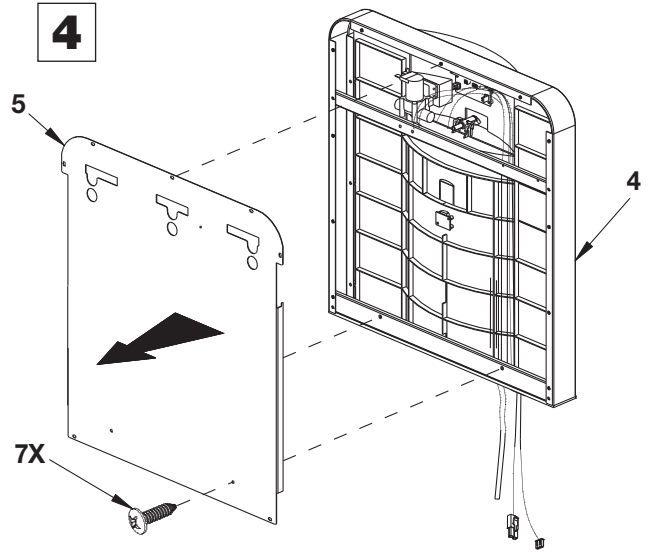

Remove back plate

Using a Phillips head screwdriver, remove Back Plate from the rear of the Bottle Filler Top Assembly by removing (3) screws. Set Back Plate aside and save screws for reinstallation.

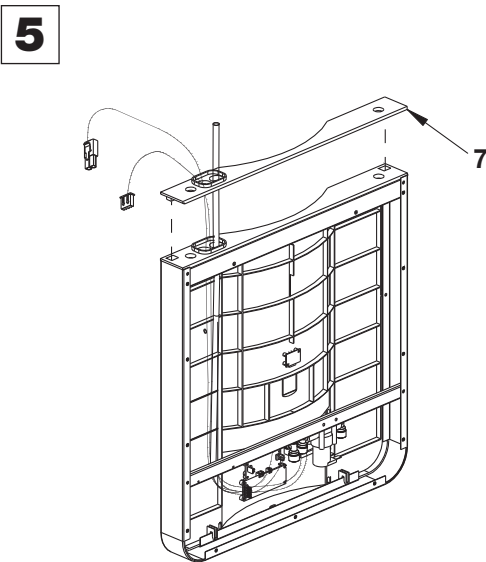

Attach gasket

Attach Gasket to the bottom of the Bottle Filler Top Assembly as shown.

Note: Ensure gasket is seated properly and lies flat so there are no gaps.

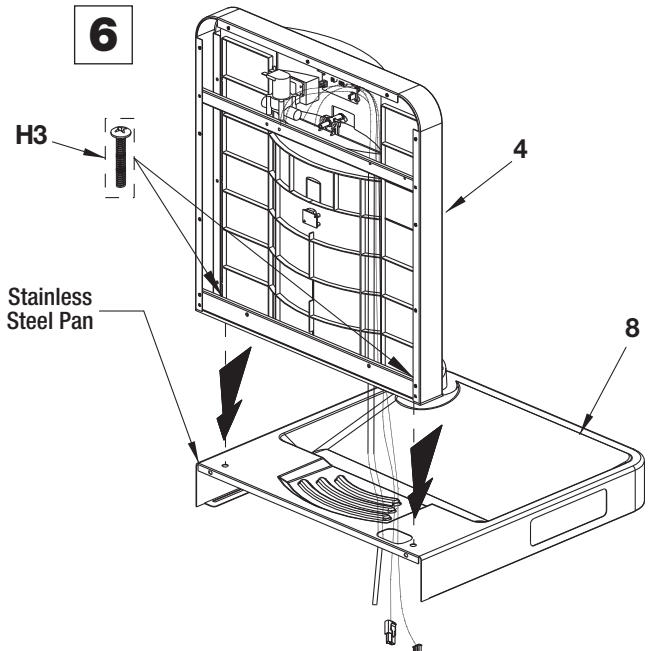

Attach bottle filler

Flip Bottle Filler Top Assembly right-side-up and carefully feed connections through the Stainless Steel Pan hole. Ensure gasket is seated properly and lies flat. Attach Bottle Filler Top Assembly to the Stainless Steel Pan using (2) H3 screws.

Wall Mounted Water Bottle Refilling Station

7A

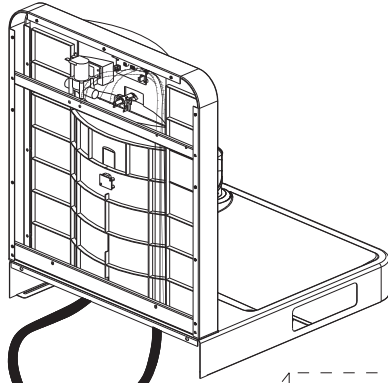

Connect Water Lines

- Connect water line (#1) from the Stainless Steel Pan to the Water Control Valve (#1) in the Cooling System.
- Push line until locked into place.
- Connect the water line (#2) in the Bottle Filler Top Assembly to the Water Control Valve (#2) in the Cooling System.
- Push line until locked into place.

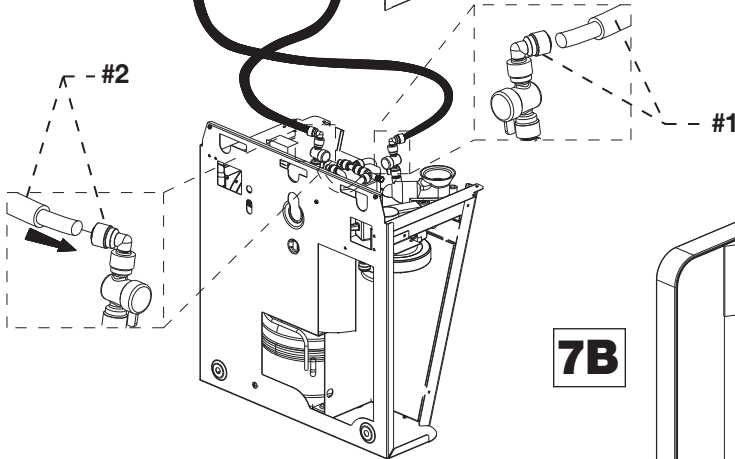

7B

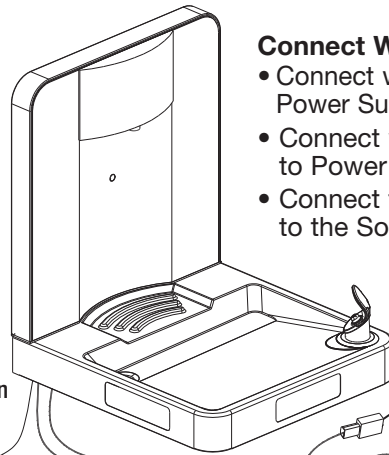

Connect Wire Connectors

- Connect white Activation Connector (C) to Power Supply (C) in the Cooling System.
- Connect white Activation Connector (A) to Power Supply (A).
- Connect the 2 Activation Connectors (B) to the Solenoid Valve (B).

Reset Button Connection

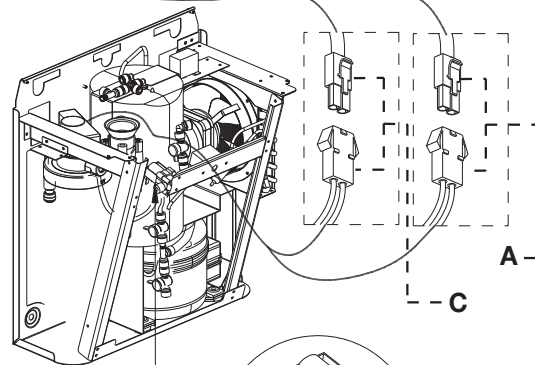

Solenoid valve

7C

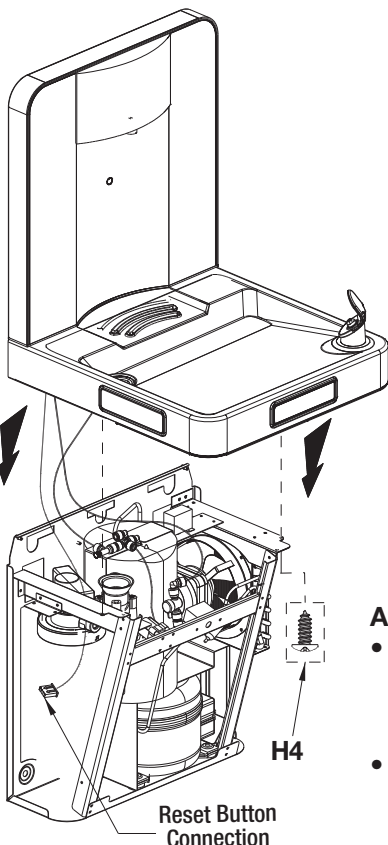

H4

Reset Button Connection

Attach stainless steel pan

- Feed the Reset Button Connection through the Cooling System's frame and carefully lower the Stainless Steel Pan on top of the Cooling System.
- Attach the Stainless Steel Pan to the Cooling System using (2) H4 screws.

CAUTION
Avoid crossing wires against sharp edges

Wall Mounted Water Bottle Refilling Station

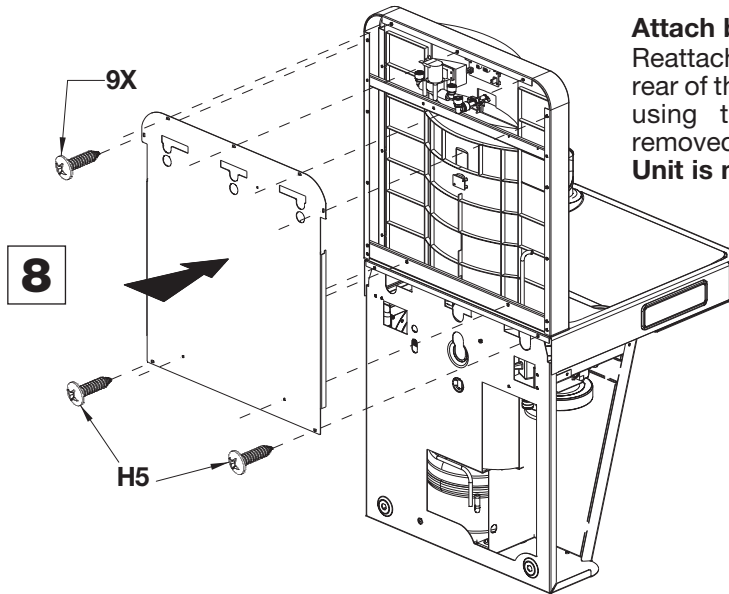

Attach back plate

Reattach the Back Plate onto the rear of the Bottle Filler Top Assembly using the (3) screws previously removed, plus (6) (H5) screws.

Unit is now ready for mounting.

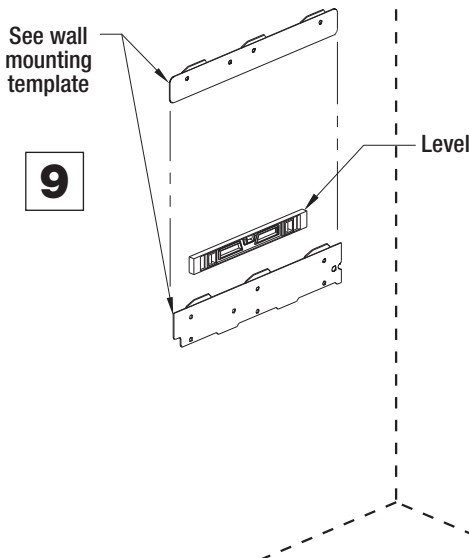

Note: To comply with ADA requirements, the base of stencil must be installed 11" to 14³/₄" from the floor. See Rough-in Guide for additional ADA requirements.

Note: Before installing brackets to the wall, assure power source, water line and drain aligns to opening on unit

Attach mounting brackets to wall

- Affix stencil with tape to appropriate wall. It is recommended to use a level to ensure the stencil is hung straight horizontally.
- Drill (9) holes appropriate for the wall anchors (75 lb. minimum each) as indicated on the top and bottom mounting brackets on the stencil. Use appropriate anchors for your wall type.
- Drill 2 holes appropriate for the wall anchors (75 lb. minimum each) as indicated on the bottom support holes on the stencil. Use appropriate anchors for your wall type.
- Remove stencil from the wall and install top and bottom brackets onto the wall using appropriate anchors.

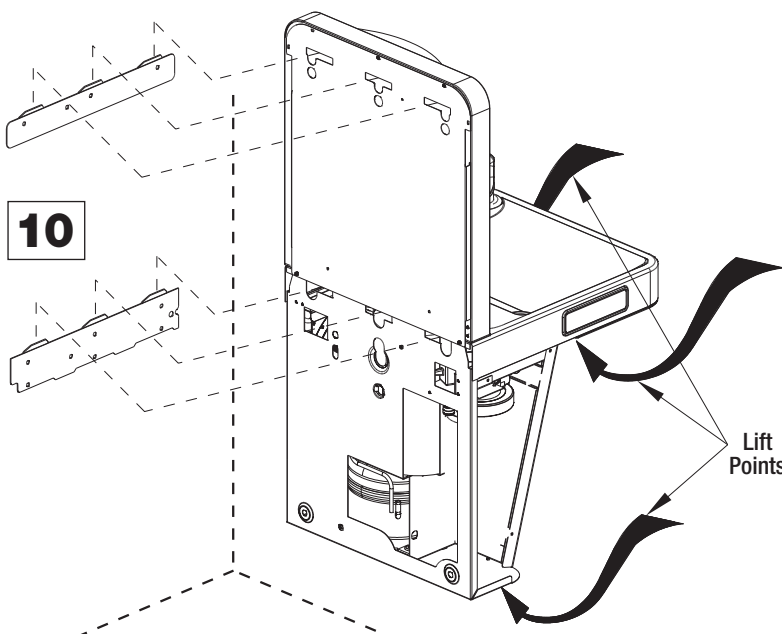

Hanging assembled unit to wall

- Carefully hang assembled bottle filler onto the wall by lowering onto both top and bottom wall mount brackets.

CAUTION

Once assembled, do not lift unit by Bottle Filler Top Assembly. Use two people when lifting. Always wear work gloves when lifting

Wall Mounted Water Bottle Refilling Station

11

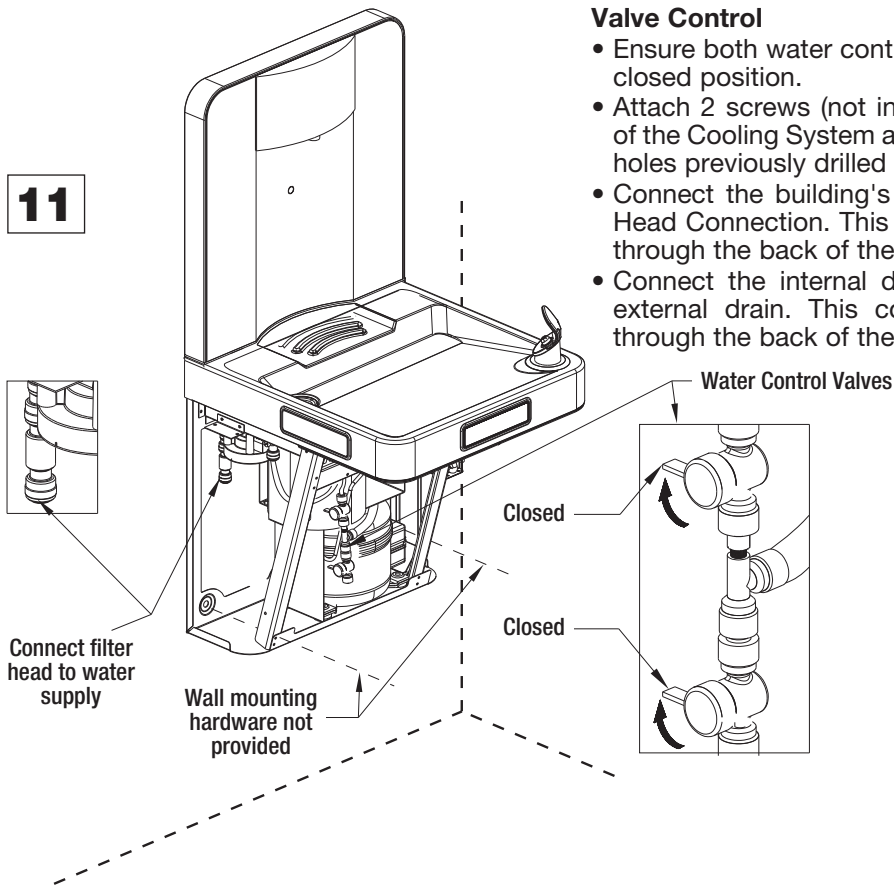

Valve Control

- Ensure both water control valves are turned to the closed position.
- Attach 2 screws (not included) through the frame of the Cooling System and into the bottom support holes previously drilled into the wall.
- Connect the building's water supply to the Filter Head Connection. This connection must be made through the back of the Cooling System.
- Connect the internal drain line to the building's external drain. This connection must be made through the back of the Cooling System.

12

Install water filter

- Remove the receiver protective cover from the water filter.
- Insert filter into the filter head by turning clockwise until locked into place.
- Turn both water control valves to the open position.
- Check all connections for leaks. If leaks are detected ensure all connections are tight and are fully inserted.

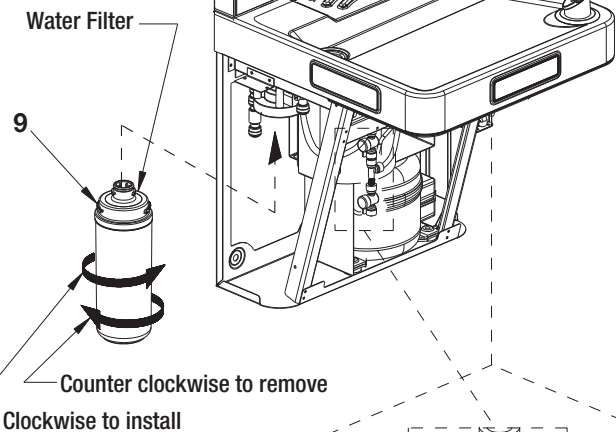

13

- Turn on buildings water supply and check all connections for leaks.
- Fix any leaks before continuing.
- Plug power cord into outlet.

Check local codes for plumbing requirements prior to installation.

Note: If cooling system is on its side or back for more than 10 minutes, allow it to stand in the upright position for 24 hours before water connections and initial power-on.

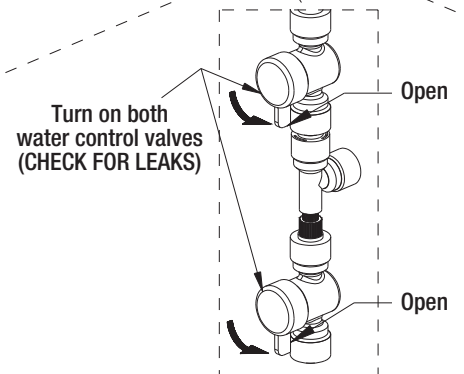

Wall Mounted Water Bottle Refilling Station

14

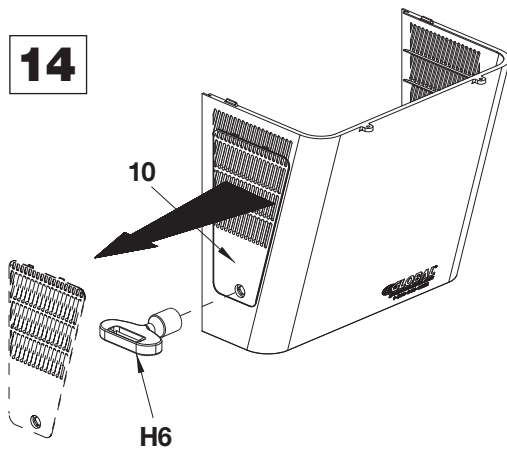

- Remove the filter access door using the provided key.

WARNING

Risk Of Electrical Shock

- Turn off power prior to performing any maintenance.
- Verify supply voltage accuracy.
- Ensure all electrical and grounded connections are in accordance with the National Electrical Code and any other applicable local code requirements.
- All wiring connections should be capped with approved wire connectors.

The warnings, precautions, and instructions discussed cannot cover all possible conditions and situations that may occur. Failure to heed these warnings may result in property damage and personal injury.

General Safety Information

- To reduce the risk of property damage, personal injury, electric shock, falling equipment, and other hazards please read all instructions and warnings.
- Installation, service, and maintenance should be
- All parties must follow proper safety procedures and precautions at all times.
- **Do Not Install Damaged Products!**

16

Connect reset cable to activation button

- Connect the Reset Button connection cable to the Activation Buttons located at the top of the filter access door frame.
- Reinstall the filter access door using the provided key.
- Unit is now ready for use.

15

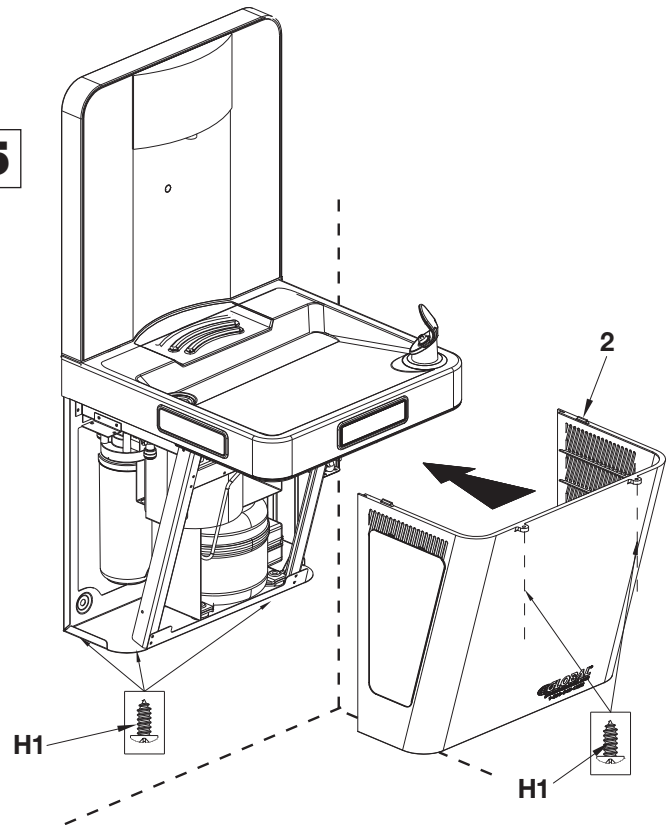

Reattach lower cover

- Reattach the Lower Cover to the Cooling System using (4) H1 anti-theft screws.
- Fasten the Lower Cover to the bottom of the Stainless Steel Pan using (2) H1 anti-theft screws.

CAUTION

Make sure all wires are tucked in before attaching cover plate to lower cover.

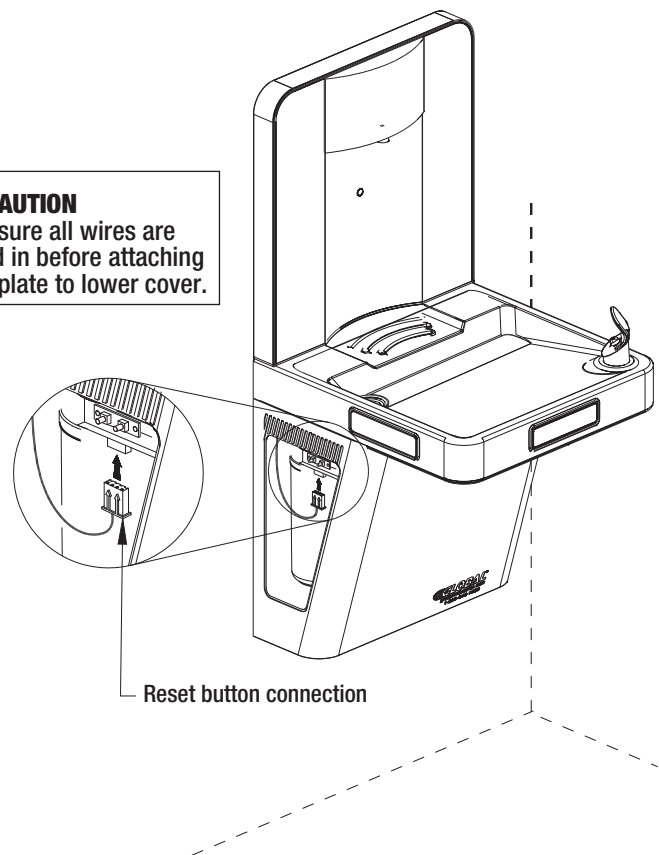

Wall Mounted Water Bottle Refilling Station

Operation

Note: Initial water flow may have sputter due to air in the water lines; this will be eliminated once air is purged from all water lines.

To operate bottle filler, verify proper dispensing by placing bottle, hand or any opaque object in front of the sensor area.

To operate drinking fountain, push front or side activation buttons on the stainless steel pan to dispense cooled-filtered water from the bubbler.

When unit is plugged in for the first time, the LCD will display: 00000000. If not, the filter monitor needs to be reset – refer to **Resetting Filter Monitor** section below.

Adjusting Settings

Water Flow Pressure: Adjust the water flow pressure as needed by turning the water control valve. Turn clockwise to decrease the water pressure, or counterclockwise to increase the water pressure.

Note: When adjusting, aim water flow to the center of the stainless steel pan.

Note: Initial dispenses may have air in line which may cause a sputter. Allow a few seconds for air to be purged from the water line.

Water Temperature: Machine comes with a preset water temperature of around 45°F. If a different temperature is required, remove Lower Cover and access the thermostat on the front housing frame. Using a flathead screwdriver, turn thermostat screw clockwise to lower temperature setting.

Note: Please allow 5-10 minutes for water temperature to change.

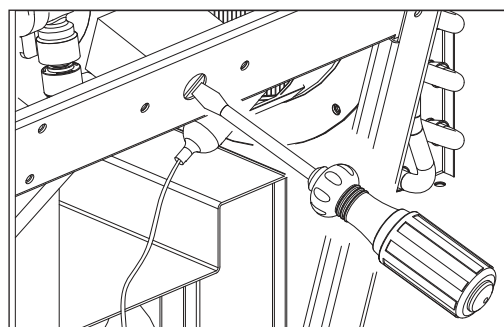
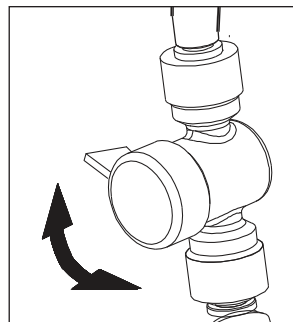

Installing/Replacing Filter

1. Remove filter access door on the lower cover using the provided key (H6).
2. Grasp old filter and turn counterclockwise to remove from the filter head.

3. Press and hold ENTER button for 5 seconds to reset this bottle counter number to zero 00000000.
4. Tap SET button 1 time or wait 5 seconds to return to standard bottle counter view.

Replacement Filters: Model 670336

For more information visit: globalindustrial.com or call 1-800-645-2982.

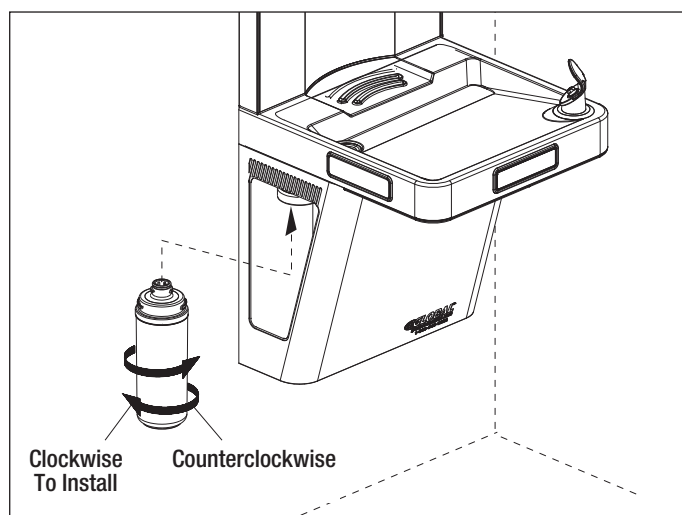
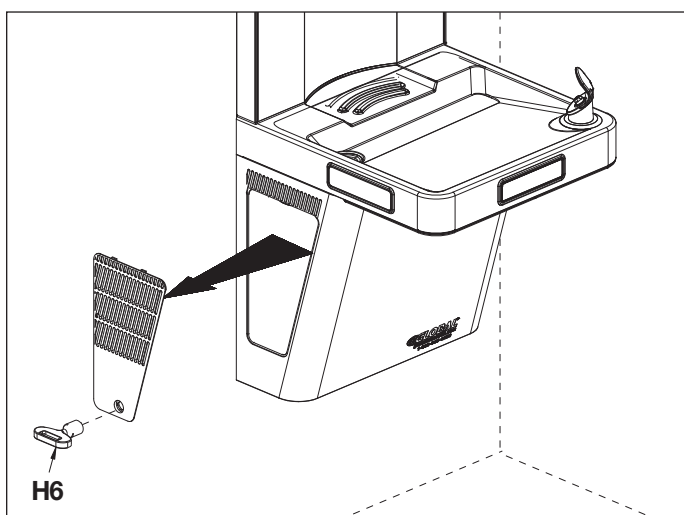

Wall Mounted Water Bottle Refilling Station

Programming Settings

Accessing the Programming Buttons:

To access the programming buttons, open the filter access door on the lower cover using the provided key (H6). The two program buttons are located on the top of the filter access door frame.

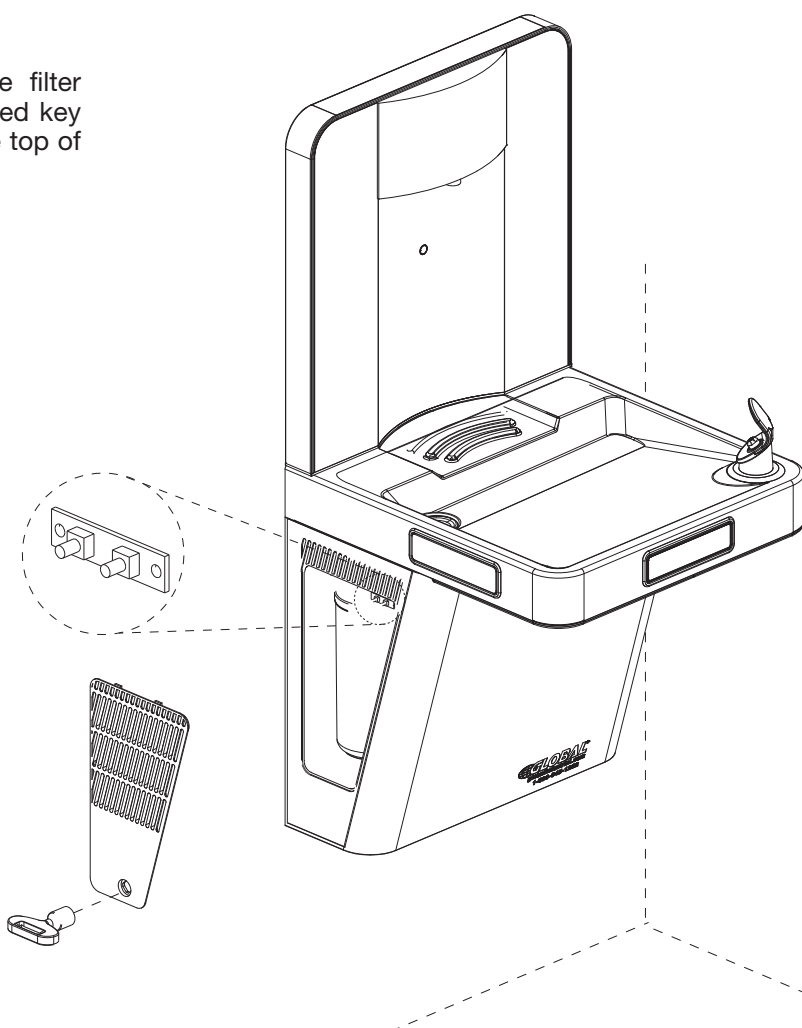
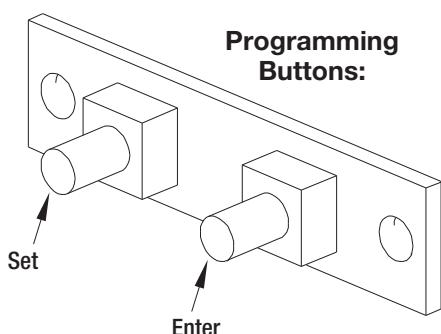

Resetting Filter Status

1. Press and hold **ENTER** button for 5 seconds, until **Reset Ft** is displayed on the LCD screen.
2. Tap **SET** button to access Reset Ft mode.
3. Press and hold **SET** button for 5 seconds to reset filter status. The LCD screen will display 0000 and the LCD filter status bar will reset to the full 5 bars.

Select Filter Size

1. Press and hold **ENTER** button for 5 seconds until **Reset Ft** is displayed on the LCD screen. Tap **ENTER** button until **Ft Size** is displayed on the LCD screen.
2. Tap **SET** button to access Filter Size mode.
3. Tap **SET** to toggle between 1500, 3000, and 3600 gallon filter size options, or No Ft to bypass filter size if a filter is not being used. **Note:** For filter capacities higher than 3600 gallons, select 3600.
4. Tap **ENTER** button to confirm your filter size.

Resetting Bottle Counter:

1. Press and hold **ENTER** button for 5 seconds.
2. Tap **ENTER** button until **Reset Ct** is displayed on the LCD screen, then tap **SET** button to access Reset Ct mode.
3. Press and hold **SET** button for 5 seconds to reset bottle counter number to zero 00000000.



4. Tap **ENTER** button 1 time to return to standard bottle counter view.

Note:

- After press and hold button for 5 seconds, tap Enter to toggle between Sens Set, Filter Size and Reset Ct available too.
- If a selection is not made within 10 seconds, system will automatically return to the standard bottle counter view.
- Changes on Sens Set mode not allowed

Wall Mounted Water Bottle Refilling Station

Filter Status Lights	
When filter level is at 100%	5 LED bars will be displayed
When filter level is at 80%	4 LED bars will be displayed
When filter level is at 60%	3 LED bars will be displayed
When filter level is at 40%	2 LED bars will be displayed
When filter level is at 20%	1 LED bar will be displayed
When filter level is at 10%	1 LED bar will be displayed and will FLASH
	LCD will FLASH between "CHG FLT" and the bottle count
When filter level is at 0%	0 LED bars will be displayed
	LCD will display "CHG FLT" entire time

Maintenance

WARNING

ALWAYS disconnect power and shut-off main water supplier prior to maintenance. Observe entire unit for **possible** water leakage.

- Inspect Cooling System every 6 months for leakage, proper operation and performance.
- When cleaning, do not use harsh chemicals, abrasive or petroleum based cleaners. **Doing so will void warranty.**
- Exterior parts can be cleaned using a soft cloth with mild detergents or soapy water. Do not use steel soap pads. Rinse and towel dry.

- Extra caution should be used to clean mirror finished stainless steel panels, as they can be easily scratched.
- Periodically clean cabinet ventilation louvers and condenser fins with a vacuum cleaner, or air hose to avoid excess dirt.
- Periodically remove the Lower Cover of the Cooling System the and clean out water drain.
- To clean blockage/debris from the bottle filler spout – twist off the silver spout, remove the filter screen and run under clean water. Reattach the screen and spout.

Troubleshooting

Issue	Possible Cause	Suggested Action
Water temperature not cool	The thermostat is set too high	Lower the water temperature on the thermostat (see Adjusting Settings, page 10).
	No power to unit	<ul style="list-style-type: none"> • Check power cord • Check the electrical receptacle for power and correct voltage; electric supply must be identical in voltage, cycle and phase to that specified on nameplate • Check for loose wires within the Cooling System • Check to see if GFCI outlet tripped
Restricted or no water flow	Water control valve(s) are closed	Access water control valve and turn on. Adjust water flow pressure as needed (see Adjusting Settings, pg 10)
	Blockage in water line	Check water supply lines and flush out any blockage
Noisy operation	Condenser fan blades not turning freely	Clear fan blades free from any restrictions
	Hardware rattling	Ensure hardware is tightened
Water not dispensing properly to bottle	Infrared sensor range needs to be adjusted	<p>The infrared sensitivity range is factory preset. If this range requires adjusting, it can be set with a sensitivity range from 01 (minimum sensitivity) to 10 (maximum sensitivity).</p> <ol style="list-style-type: none"> 1. Access programming buttons (see Programming Settings, pg 10). 2. Press and hold SET button for 5 seconds until Reset FT is displayed on the LCD screen. Then tap SET button 1 time to toggle to Sens Set 1. setting on the LCD screen. 3. Tap ENTER button multiple times to toggle through desired range and set to user preference. 4. Tap SET button 3 times or wait 5 seconds to return to standard bottle counter view.