

User's manual

Manual del usuario

Manuel de l'utilisateur

Customer Service  
US: 1-800-645-2986Servicio de atención al Cliente  
US: 1-800-645-2986Service à la clientèle  
Canada: 888-645-2986

# Dual Charging Station

Model: 812545

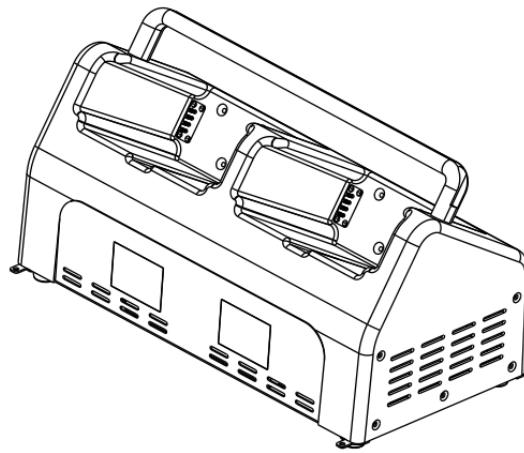

Read this manual thoroughly prior to installation, operation or maintenance. Keep these instructions in a safe location for future reference. For questions, visit [globalindustrial.com](http://globalindustrial.com) or contact Customer Service at 1-800-645-1-800-645-2982.

## WARNING

- Failure to follow installation instructions will void warranty.
- When plugging in or pulling out the battery, please be cautious about the operation to avoid pins damage;
- The product should be kept away from fire, high-temperature environments, and humid and rainy environments during use and storage, otherwise it may lead to dangerous situation.
- Non-professionals should not disassemble it by themselves.
- Do not discard the product at the end of its service life. Recycle the product according to local laws and regulations.
- This product should be protected from rain, water immersion, moisture, and violent vibration during transportation.
- It cannot be used at an altitude exceeding 2000m.
- Do not drop, squeeze, or collide with the product, so as not to subject the product to external pressure, which may cause a short circuit of the internal circuit of the product and damage to the battery.
- After use, please turn off the machine in time
- Please charge by the supplied power cord. Please apply the specified battery.
- When the product accidentally drops into the water while using, please unplug the input socket and place it in a safe and open area. The product shall not be turned on.
- While using or delivering the product, its screen should be carefully protected from strike.
- When the product is on, it is forbidden to touch pins in the battery compartment with hands or metal devices.

# Dual Charging Station 812545

## Technical parameters

Item	Parameter
Charging Power	294W*2
Input Information	AC INPUT:100-240V 50/60Hz 10A Max
Charger Output	DC OUTPUT : 29.4V 10A Constant Current and Constant Voltage * 2
Battery	LiFePO4 8S 20/25AH
Product Size	18.89 x 10.55 x 10.47 inch ( L*W*H )
Product N.W.	15.18 lbs
Product G.W.	20.32 lbs
Working Environment	14-104°F Relative Humidity≤80% Altitude≤2000M
Transport and Storage Environment	Temperature: 5-131°F Relative Humidity≤93% ( no condensation ) Atmosphere Pressure:70kPa ~ 106kPa

## Package Contents:

- AC Power Cord \* 1
- Product Instruction Manual \* 1
- Dual Charging Station \* 1

# Dual Charging Station 812545

## Application and Function Instruction:

A dual charging station which uses two internal chargers with constant current and voltage can charge two batteries or one battery independently. When the battery needs to be charged, it can be inserted into the plastic station to complete the process. This product can protect itself from input over-current. What's more, the charger output voltage is the DC safe one, which has functions like short circuit and anti-reverse connection protection, and no-load impulse. The product has two 1.7-inch LCD screens, which display the status of two batteries independently and show charging prompt as well as high-precision battery capacity when charging.

## Product Main Structure Composition

The charging station is mainly composed of a sheet-metal base, battery plastic base, charger, and LCD screen.

### Front of Charging Station

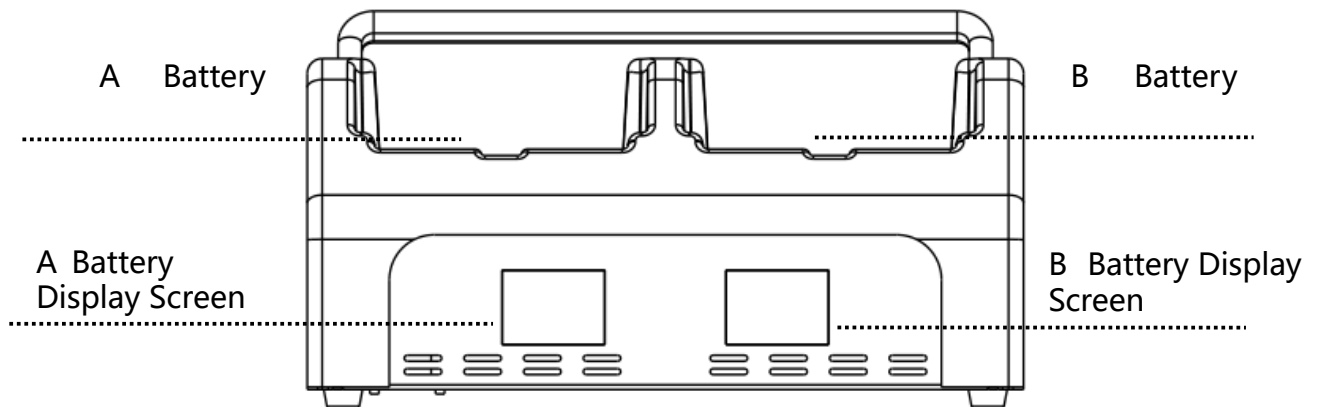

### Rear of Charging Station

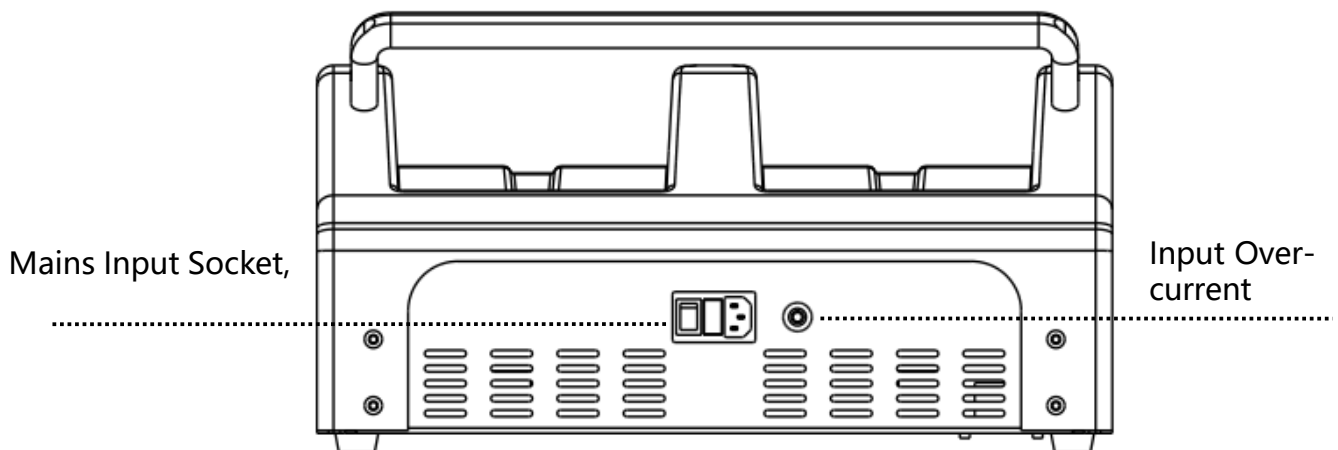

# Dual Charging Station 812545

## Operation and Usage

1. Check whether there is any visible damage to the appearance of the product and whether the input socket or the battery pins are loose or damaged (If abnormal conditions occur, stop using).
2. Plug one end of the supplied power cord into the AC socket on the back and connect the other end to the mains.
3. Plug one battery or two batteries into the plastic battery compartment in the product.
4. Turn on the power switch on the back of the product and check the screen. At this point, the battery grid icon on the display screen will flash to indicate that it is charging.
5. Turn off the power input switch and pull out the battery after charging.

## Product Maintenance

1. Socket contacts in the battery compartment are fragile so they should be inspected regularly. The deformed or cracked one should be replaced. Otherwise, it may cause charging failure.
2. Regularly remove dust and dirt from the heat dissipation window.
3. Regularly check whether the external screws and lifting rings of the chassis are fully tightened.

## Troubleshooting

Issue	Suggested Action
No Response When Power on	<ul style="list-style-type: none"> <li>• Confirm whether the mains input voltage is within the range of the product specification.</li> <li>• Check whether the fuse inside the input socket is damaged.</li> <li>• Check whether the over-current protector on the back is disconnected.</li> <li>• Check whether the power cord is in open-circuit or broken.</li> </ul>
Unable to Charge	<ul style="list-style-type: none"> <li>• Confirm whether the battery is completely inserted into the battery compartment and the sockets in the bottom of the battery should be completely connected to the battery station pins.</li> <li>• Check whether the battery station pins are deformed or falling off.</li> </ul>