

# LP600™ Wheel Load Scales

Low-Profile, Lightweight Digital Wheel Load Scales



## ***Maximize Legal Payloads & Reduce Maintenance due to Overload Stress on Equipment.***

Weighing a mere 51lbs (23kgs) with a profile of just 1.5" (38mm), the LP600™ Low-Profile Wheel Load Scale weighs loads up to 30,000lbs (15,000kgs) with an accuracy of  $\pm 1\%$ . Progressive solar charging technology allows the commercially available AA rechargeable batteries to be powered for up to one year with daytime, outdoor use.

Fully Integrated RFX™ Wireless Weighing Technology makes it possible to sequentially couple and number scales in a series for total weight and scales can be linked to a multitude of Intercomp weighing indicators. For customers whose local regulations prevent the use of wireless communications, radios can be disabled or Intercomp offers a full line of hard wired alternatives.

# LP600™ Low-Profile Wheel Load Scales



NTEP/OIML Certified Models Available

Accuracy of  $\pm 1\%$  of Reading



Solar Boost Provides up to One Year of Battery Life with Daytime, Outdoor Use

Large LCD Display with Backlight for Easy Readings from Scales



Low-Profile Height of Just 1.5" (38mm)

Available in Capacities to 30,000lbs (15,000kgs)

Integrated Indicator with Comprehensive Push Button Controls Include:  
On/Off, Local/Total, Zero & Print/Accum



RFX™ Wireless Weighing Technology Provides Cable-Free Communication with a Variety of Indicators, Apps & Software

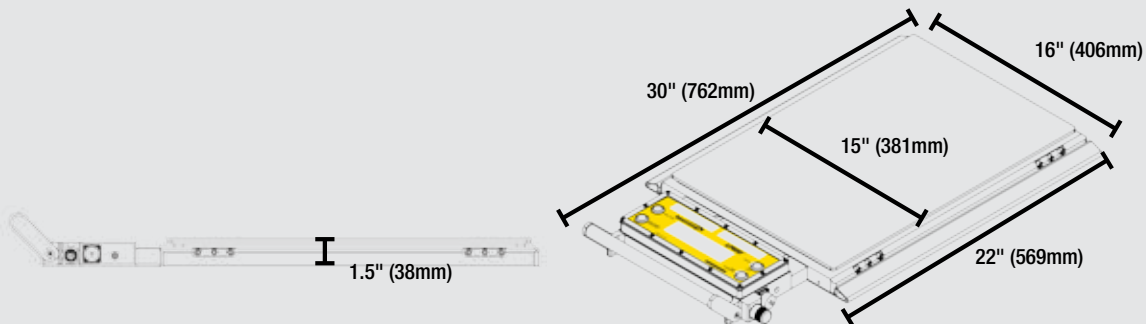

## Compatible with These Intercomp Devices



### Wireless Handheld Weighing Indicator

Easily process weight related data to monitor and control loads in a compact, handheld device.



### PT20™ CPU

Enclosed in a rugged, weather-resistant case, this portable weight management CPU features wireless communication and integrated printer; ideal for remote use.



### IntercompWeigh™ Software

Manage any weighing process, view scale data, customize layouts and generate reports in one, easy-to-use program.

(PC Not Included)



### iVehicleWeigh™ Scale App

Input weight data into an iPhone®, iPod® or iPad® to save and email information easily and conveniently.

Available for download  
**FREE** from iTunes®.



### S400™ Display & Wireless Printer

Offers wireless communication with scales through the RFX™ Data Converter.



[intercompcompany.com](http://intercompcompany.com)

Specifications subject to change without notice.

