



**GLOBALTM
INDUSTRIAL**

We can supply that.[®]

User's manual

Manual del usuario

Manuel de l'utilisateur

Customer Service
US: 1-800-645-2986

Servicio de atención al Cliente
US: 1-800-645-2986

Service à la clientèle
Canada: 888-645-2986

Bench-In-A-Box Standard Workbench

B2334702: 72"W x 30"D ESD Laminate Top (ref page 3)

B2334703: 72"W x 30"D Plastic Laminate Top

B2334704: 60"W x 30"D ESD Laminate Top (ref page 3)

B2334705: 60"W x 30"D Plastic Laminate Top

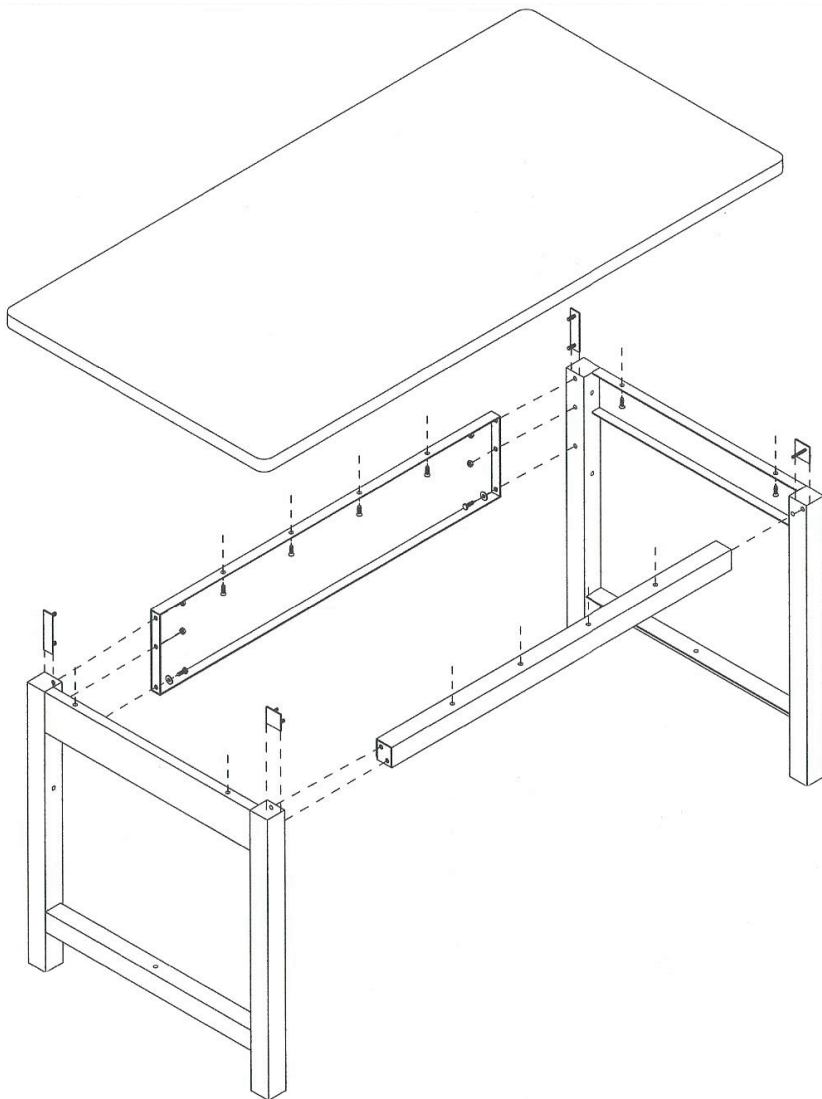

1. Assemble front and back rail using stud plates and lock nuts provided. The 2 x 2 x 1 channel is for the front of the unit and the 1 x 8 channel is for the rear. Then attach the 1/4" - 20 x 3/4" hex head bolt and flat washer to the bottom most hole in the back rail (before tightening nuts, make sure that the front rail and back rail are flush to the top of the leg assemblies and pushed inward approximately 1/8" to allow the work surface to be mounted properly.
Note: Holes in rails should be facing up
2. Place work surface bottom up on a protected surface to protect laminate from scratches. Place assembled frame on backside of top. Locate flush with back edge of leg (seam of edging to back). Use pre-drill holes 1/2" deep and screw #12 x 3/4" screw in to secure frame to top.
Note: Overhang of the top should be 2 1/2" in front and the sides (flush with back).

When assembling, an electric screw gun is recommended.

Technical Workbench

1. Sleeve leg extender into leg at desired height and place bolt assembly as shown and tighten.
2. Screw Nylon glides into leg extenders.

NOTE: If the leg extenders are fitting tightly and are not sliding easily into the legs, remove extender and with a rubber mallet hit along both sides of the extender to slightly bend the channel inwards.

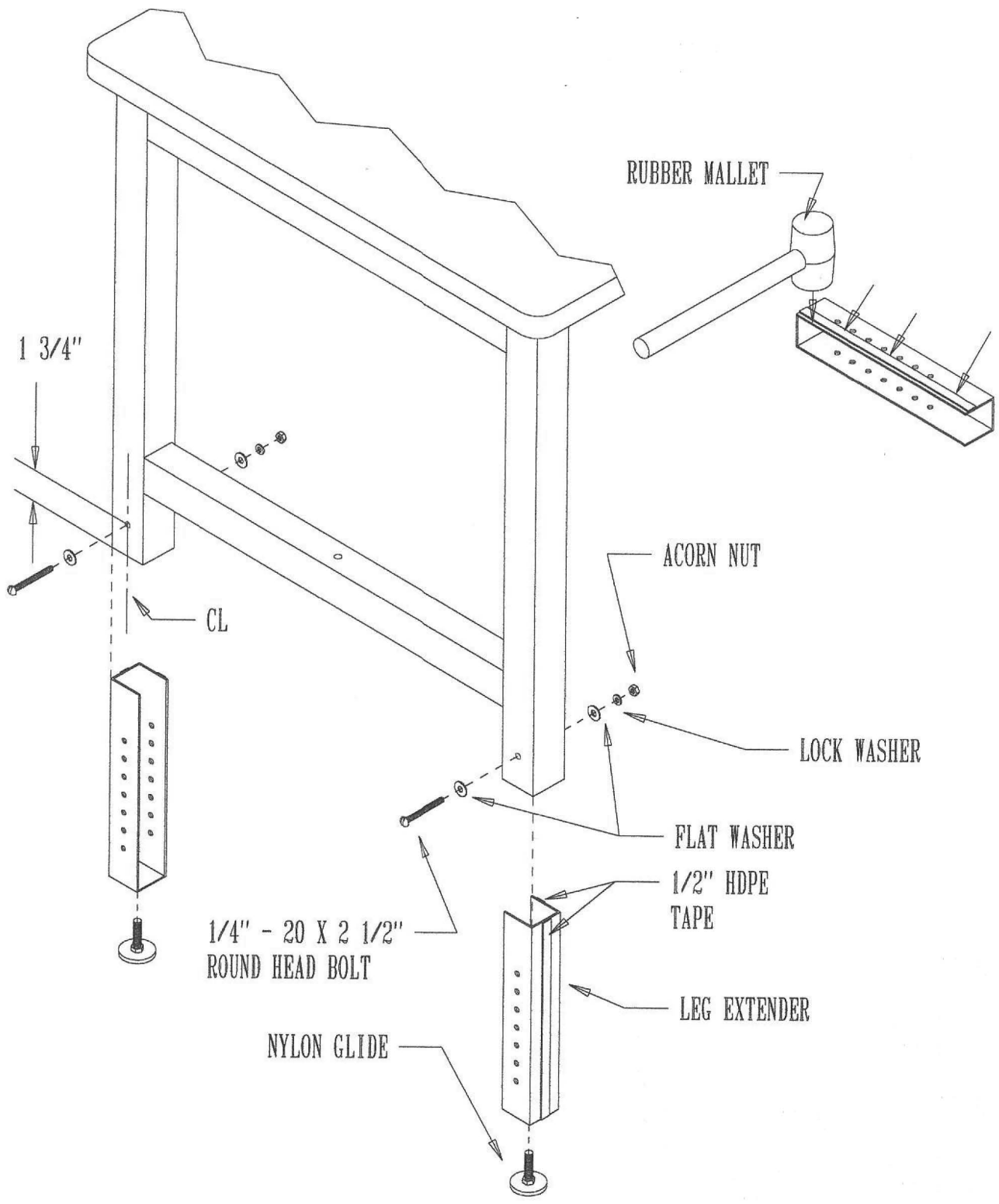

Standard Workbench

ESD installation only for below models:
 B2334702: 72"W x 30"D ESD Laminate Top
 B2334704: 60"W x 30"D ESD Laminate Top

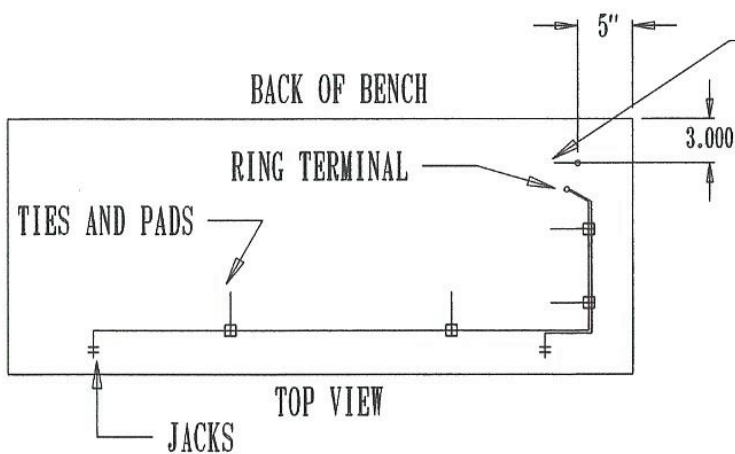
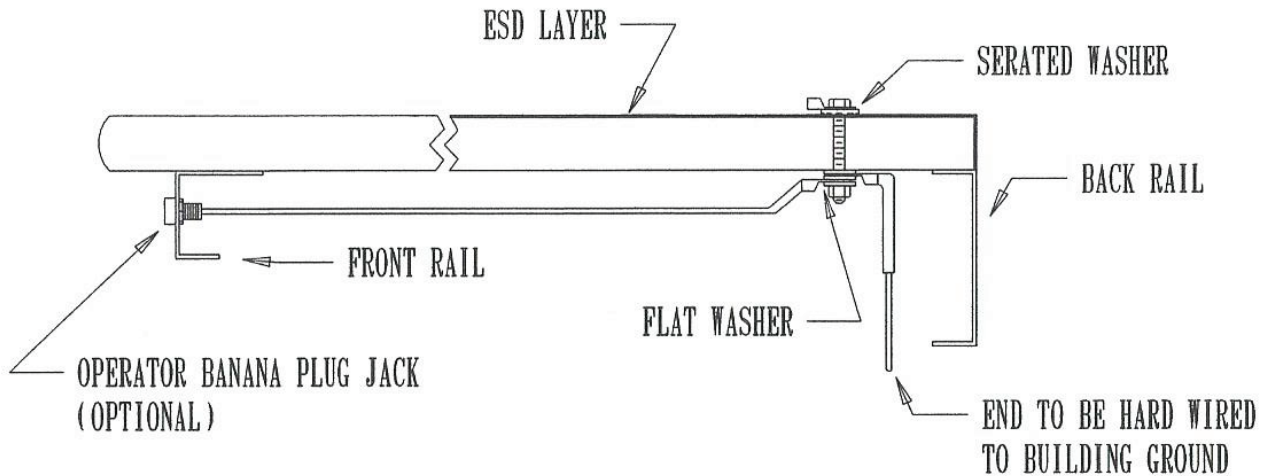

DRILL 3/8" HOLE (IF NOT ALREADY PREDRILLED) THRU AND INSTALL GROUND BOLT

1. Drill 3/8" hole in work surface per measurements in the top view (if not already pre-drilled).
2. Install 5/16" x 2" hex head bolt, ring terminal and serated through work surface. On underside of work surface install washer, ring terminal, washer, ring terminal, washer, and nut in this order and tighten.
3. Mount Jacks into front rail using nuts provided.
4. Run wires in manner shown in top view using wire ties and self stick pads (4 to 6 per bench)
NOTE: Pads stick better to metal surfaces.
5. Cut wires to appropriate length by pulling wires (to remove excess slack) towards the hole in the work surface and adding 1" to that. Strip wires back 1/4" and install the ring terminal by crimping it to both exposed wires at the same time.

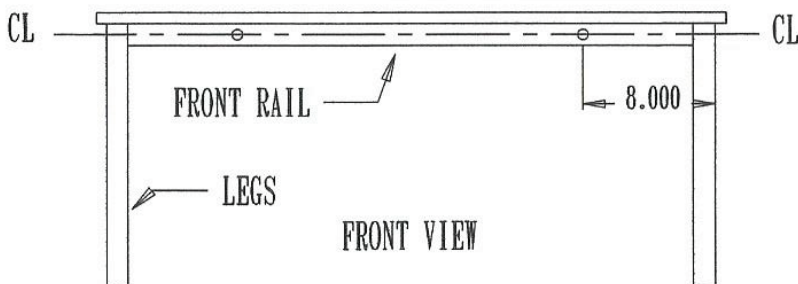

Standard Workbench

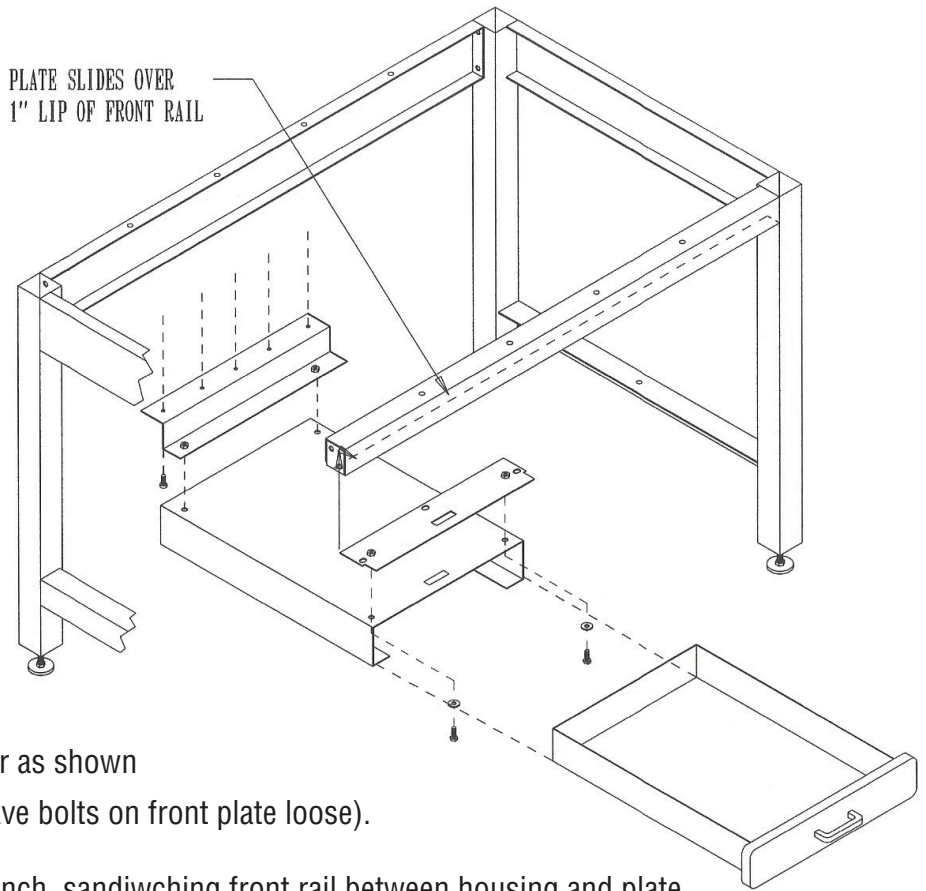

1. Remove drawer from housing.
2. Mount brackets to drawer using 1/4" x 3/4" hex head bolts and washer as shown (Tighten bolts on rear bracket but leave bolts on front plate loose).
3. Slide housing over front rail of bench, sandwiching front rail between housing and plate.
4. Set drawer housing a minimum of 1" away from leg and 3/4" set back from front rail.
5. Install five (5) #12 phillips pan pan head screws through rear bracket and into bottom of the work surface. Tighten the bolts securing the front hanging plate.

NOTE: Drawers are more easily mounted when bench is flipped upside down.

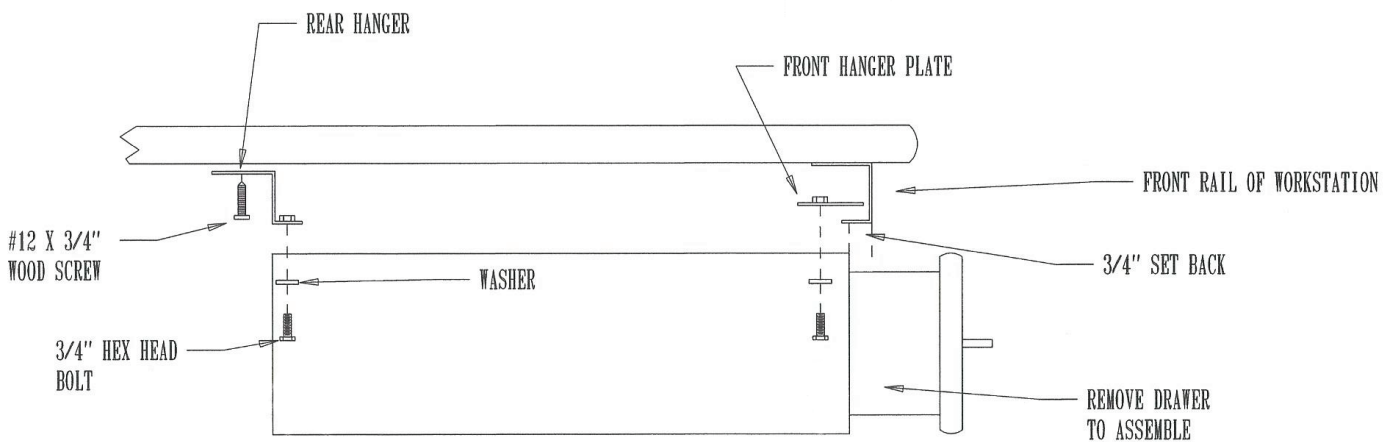

Standard Workbench

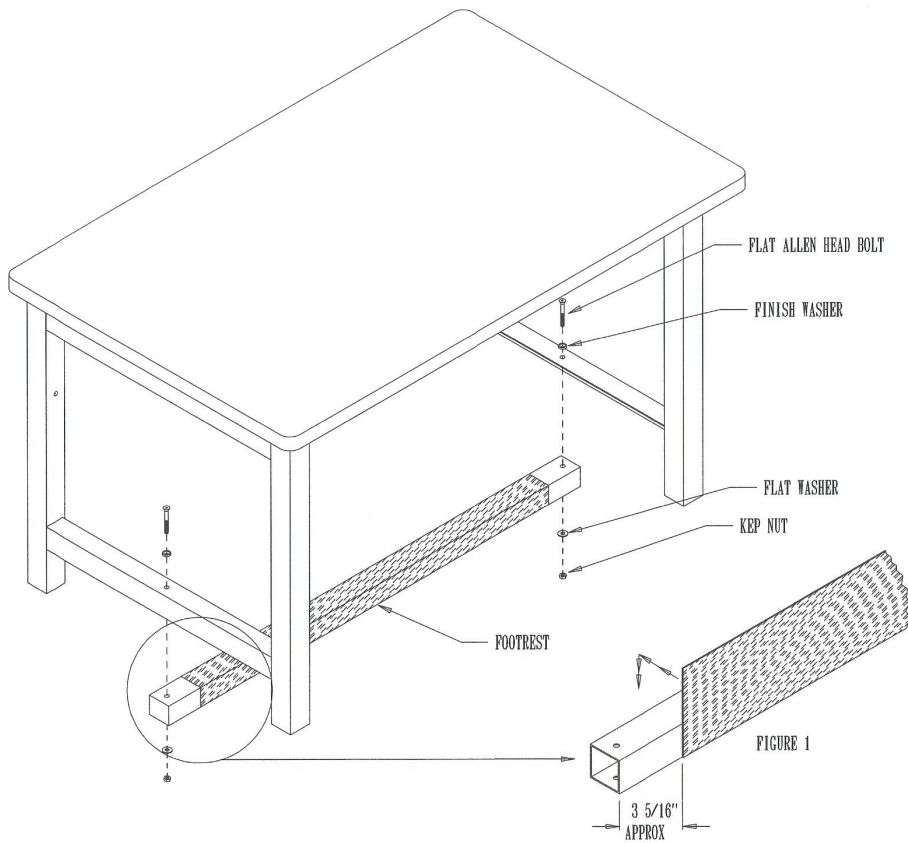

1. Peel wax paper off adhesive side of footrest guard tape.
2. Center footguaged tape along length of footrest, as shown in figure 1.
3. With a small block of wood, press back and forth along length of tape for good adhesion.
4. Work your way around the tube one side at a time.
5. Assemble footrest as shown using 1/4" - 20 x 2 1/4" flat allen head bolt, finish washer, flat washer and keep nuts provided.

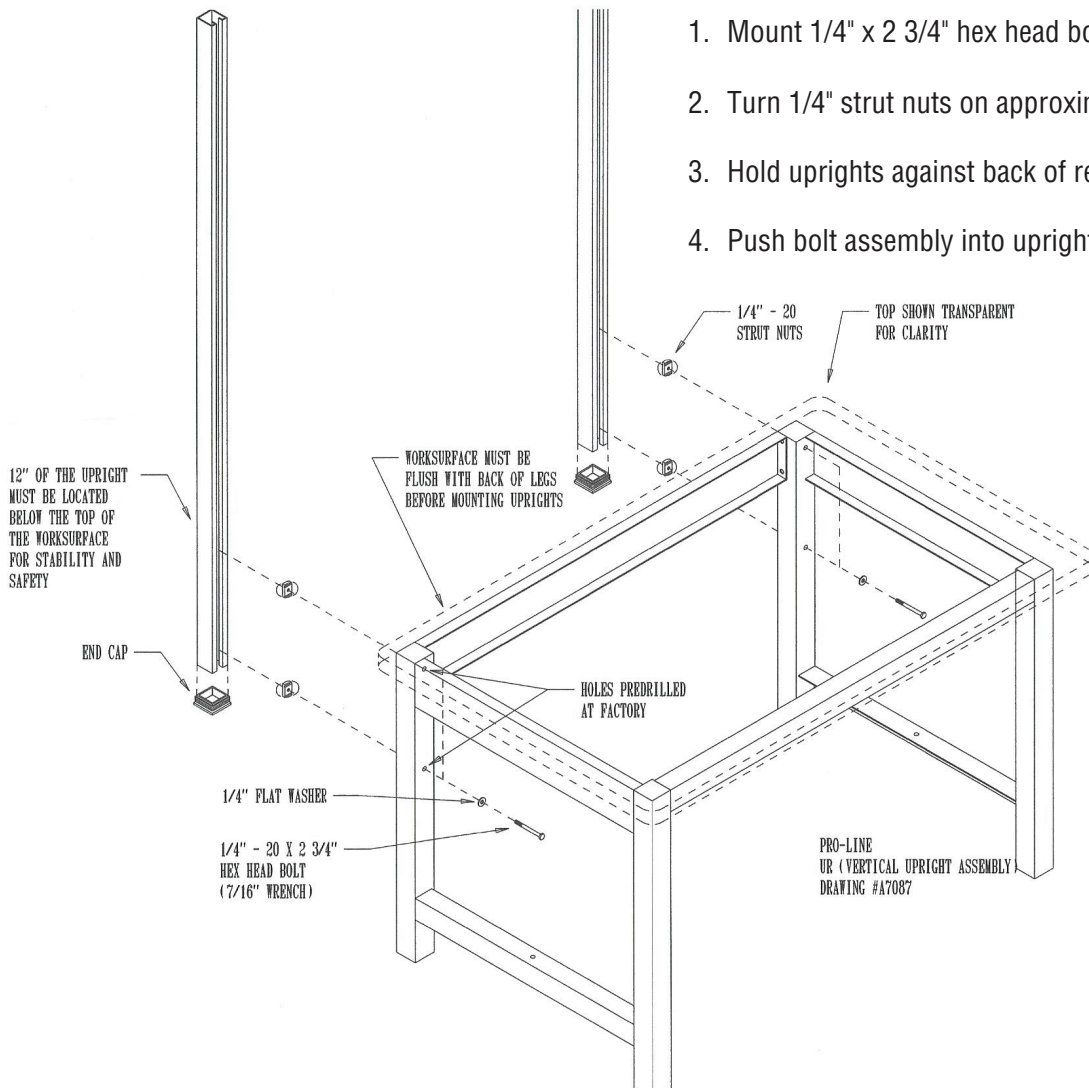

1. Mount 1/4" x 2 3/4" hex head bolts through rear legs as shown.
2. Turn 1/4" strut nuts on approximately two (2) threads.
3. Hold uprights against back of rear legs.
4. Push bolt assembly into uprights and turn clockwise to tighten.

12" OF THE UPRIGHT MUST BE LOCATED BELOW THE TOP OF THE WORKSURFACE FOR STABILITY AND SAFETY

WORKSURFACE MUST BE FLUSH WITH BACK OF LEGS BEFORE MOUNTING UPRIGHTS

HOLES PREDRILLED AT FACTORY

PRO-LINE
UR (VERTICAL UPRIGHT ASSEMBLY)
DRAWING #A7087

Standard Workbench

1. Locate and remove the knockouts that are closest to the ends of the light fixture.
2. Fasten light fixture to light support tube as shown with 1/4" x 2 flat allen machine screw, finish washer, (2) flat washers, (2) fender washers and a kep nut.
3. Attach the light frame to vertical uprights using 3/8" x 1" allen cap screws and strut nuts.
4. Assemble the 2" knobs through welded frame and into threaded inserts in tube ends. (Use washers as shown).

NOTE: It is suggested that 2 people perform the operation of mounting light tube to frame.

Bulb Requirements

48" Fixtures F32 T8

36" Fixtures F30 T8 ; F25 T8

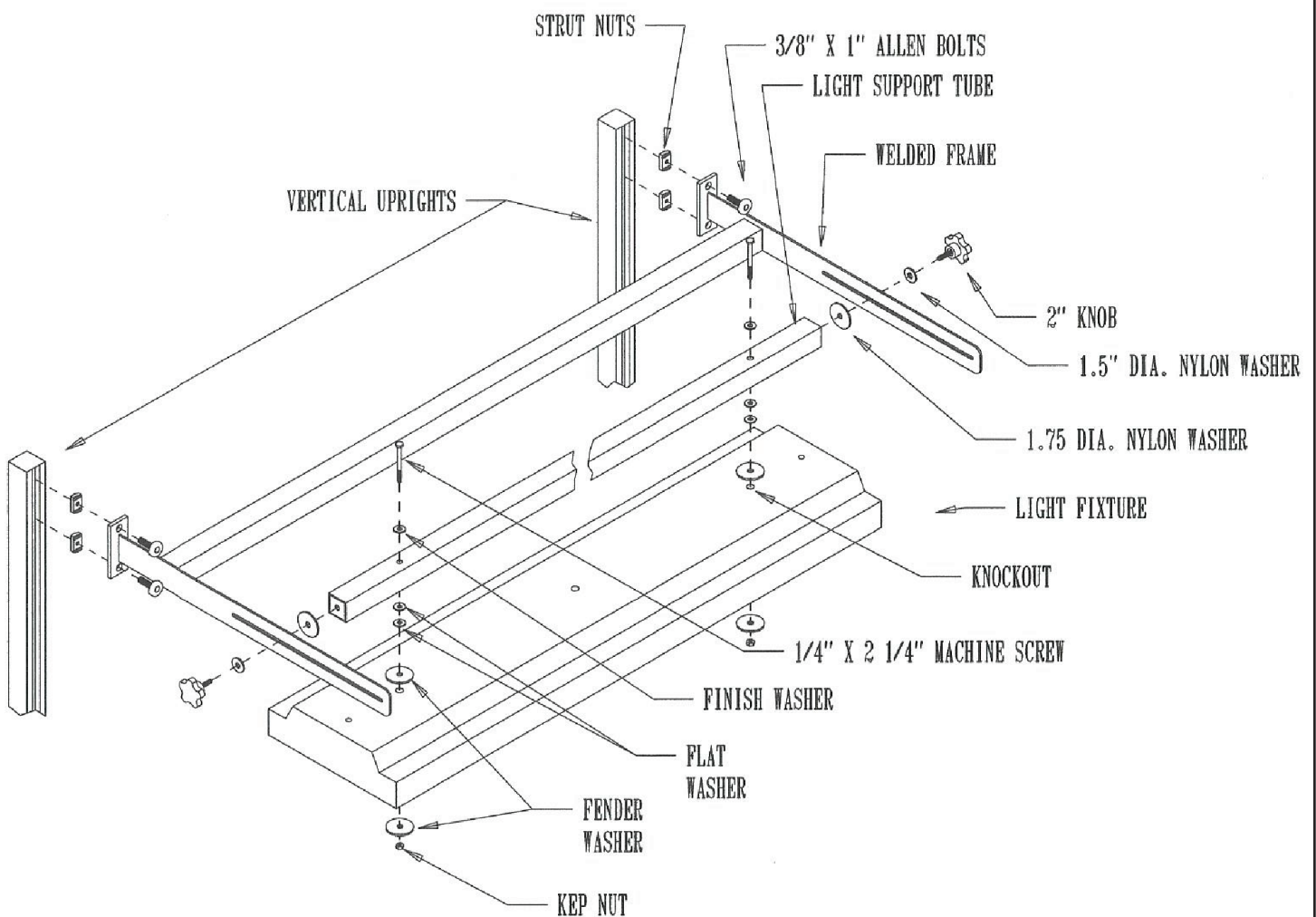

Standard Workbench

Tools Required:

1 screw gun with #3 phillips head
tip 7/32" allen wrench

1. Choose desired height on uprights and mount shelf brackets to the uprights with 3/8" x 1" allen machine screws and strut nuts provided.
2. Lay plastic laminated shelf across shelf support brackets with equal overhang on left and right sides.
3. With 2 people (one on each side of shelf), hold shelf support strut against shelf support brackets and install #12 x 3/4" Phillips pan head screws in each end. Then proceed to install the remainder of the pan head screws.

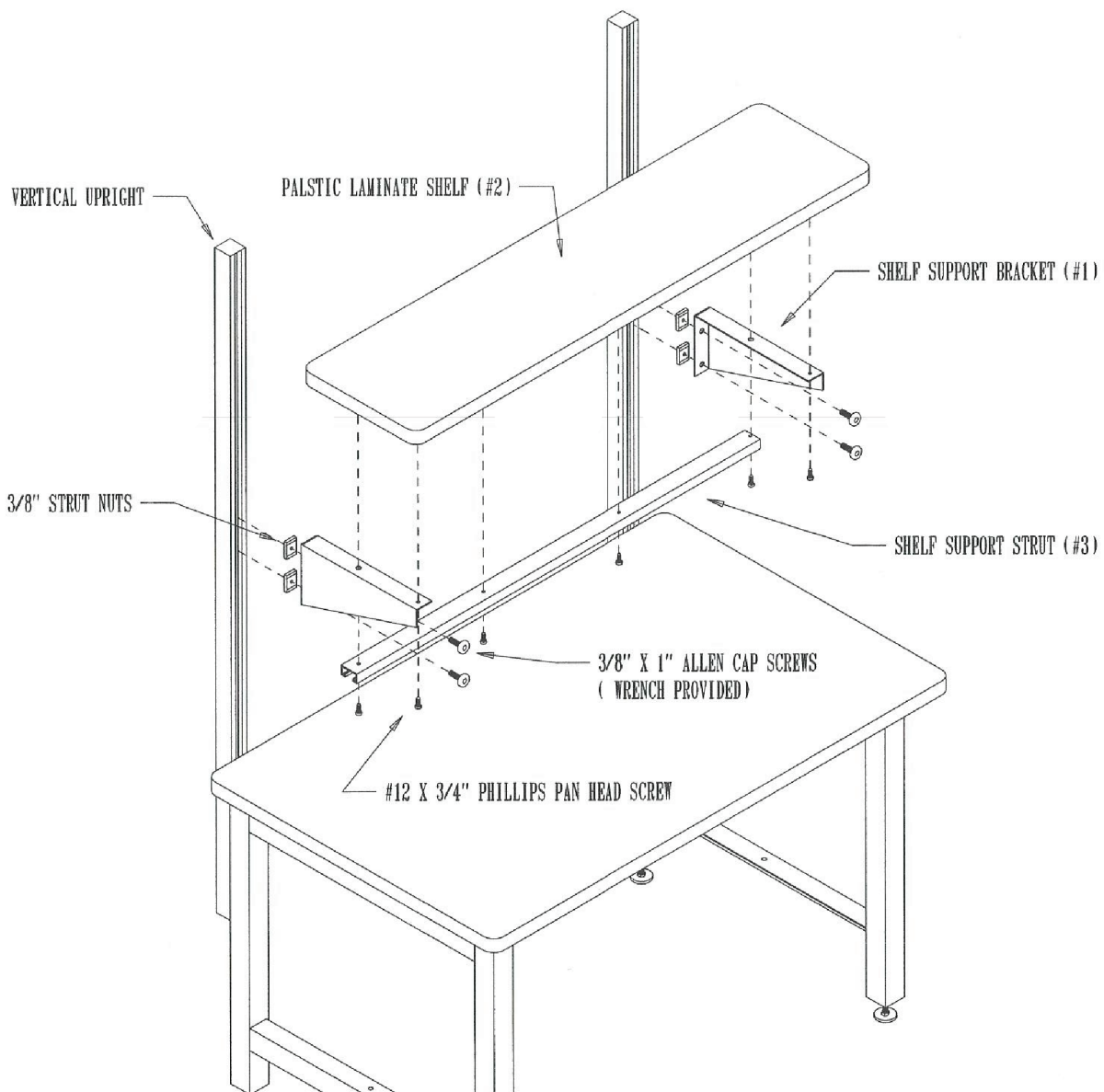

Standard Workbench

1. Fasten bin holder to uprights at desired height using 3/8" x 1" allen cap screws and 3/8" strut nuts.

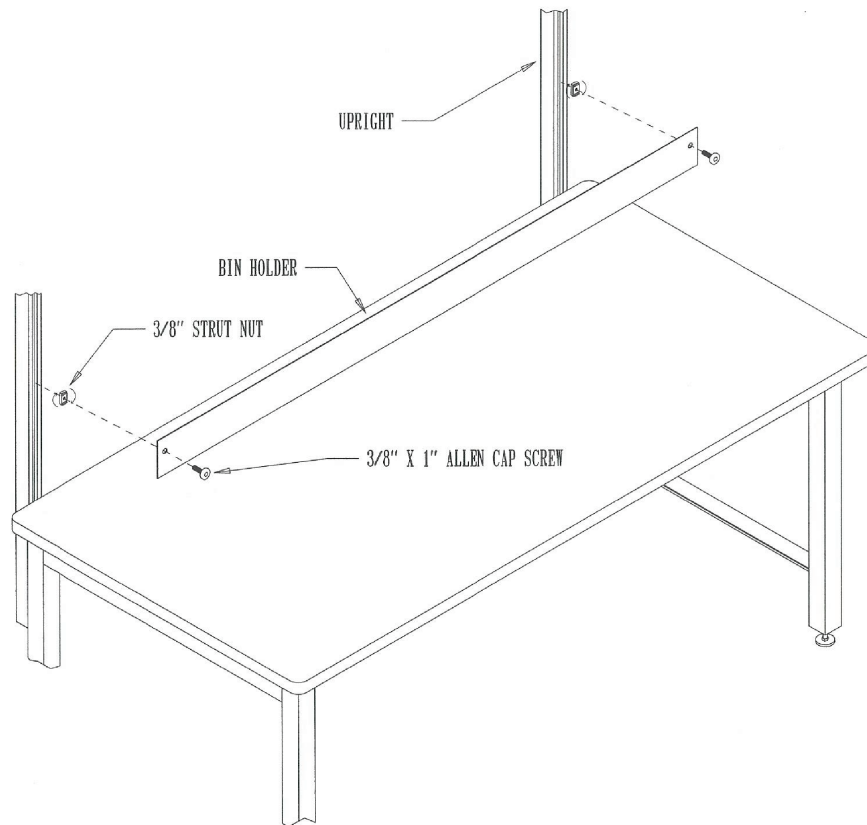

1. Fasten ESMR to the uprights with 3/8" x 1" allen cap screws and 3/8" strut nuts.
2. Secure the electrical strip to the ESMR as shown using 6/32" x 3/8" round head machine screws and 6/32" hex nuts.

