

Product Data Sheet

TABLE TOP BURNER

No. **58253** - 11/15

PRODUCT NUMBER: 8253



I. GENERAL DESCRIPTION

Features: This Table Top Burner is a butane powered cooking appliances that operates on Butane Fuel Cartridge #1214 and rated at 7,650 BTU/hour. Features include a heavy gauge metal body and porcelain enamel coated steel trivet and drip pan, piezoelectric ignition, and a hard-sided carrying case. This stove is listed to UL standards for outdoor gas-fired appliances. Safety features include an anti-explosion safety device which will automatically disengage the butane cartridge if increased gas pressure is detected, and the butane fuel cartridge cannot be engaged if the ignition knob is not in the off position.

Benefits: This portable stove is a versatile and efficient cooking surface that designed for outdoor use. The durable construction will provide long-lasting performance. The extra large cooking surface will hold standard sized cookware.

Uses: The perfect portable stove for cooking while camping, picnicking, or barbecuing or an addition to an emergency preparedness kit. May also be used for catering and banquets at outdoor events.

Warnings: **NOT FOR INDOOR USE.** Do not use indoors or in an enclosed space such as a tent or vehicle. Read all instructions thoroughly prior to use. To reduce the risk of explosion or rupturing the butane cartridge, do not expose stove or fuel to heat or open flame other than when used together. Do not store at temperatures above 110°F.

Caution: All burning appliances consume oxygen; use with proper ventilation. Never use cookware that extends over the trivet or fuel cartridge door. Make sure unit is set on a stable, hard surface and in an upright position. Avoid strong winds. Use only with Max Burton® Butane Fuel Cartridges #1215 or Butane Fuel Cartridge #1214.

Only compatible with:
Butane Fuel Cartridge #1214
Max Burton® Butane Fuel Cartridges #1215

Packaging:

Each box:	5 lbs. (2.26 kg)	0.38 CF (0.01 CM)	13.5" L x 4" W x 12.125" H
Case (3/case):	16 lbs. (7.3 kg)	1.29 CF (0.04 CM)	14" L x 12.5" W x 12.7" H

II. DIAGRAM

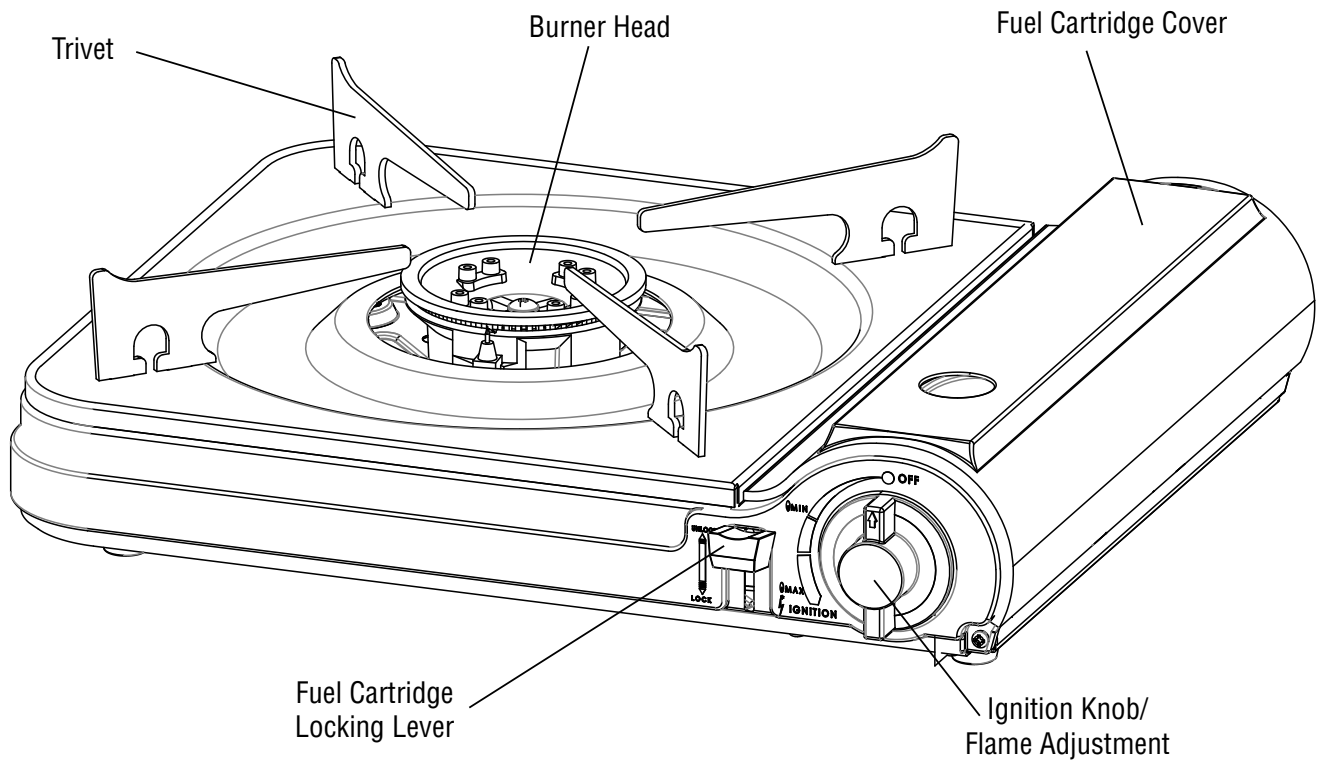

III. SPECIFICATIONS

Construction	Body - heavy gauge metal
	Drip Pan/Trivet - porcelain enamel coated steel
Ignition Method	Piezoelectric
Fuel Consumption	160 g/h
BTUs/Hr	7,650
Safety Approvals	UL-US to ANSI Z21.72b-2002/CSA 11.2b-2002

GAS-FIRED



Burning Time per Fuel Cartridge	2-3 hours (medium to high flame)
Fuel Source	Butane Fuel Cartridge #1214 or Max Burton Butane Fuel Cartridge #1215
Weight	3.5 lbs. (1.6 kg)
Dimensions	12.8" L x 11" W x 3.5" H (325 x 280 x 89 mm)

IV. MISCELLANEOUS

Note: Burn times will vary depending on the outside temperature, the fuel release rate, and altitude.

V. WARRANTY

1-year warranty to the original registered owner on all products from date of purchase. User returns, exchanges and defective refunds must be made with the original place of purchase. Because Aervoe cannot control Buyer's handling or use of product, Aervoe makes no warranty expressed or implied when not used or stored in accordance with directions. Aervoe shall not be liable for cost of labor, incidental or consequential damages, and this warranty is limited to replacement or repair of product or credit of purchase.