

- Usable I.D.: Approx. 28.75" x 28.75" x 22.38"
- Capacity: 4000# Evenly Distributed Load.
- Stacking: 5 High Max./Static.
- Handling: 4" Under Clearance On All Sides.
- Finish: Unpainted Bare/Raw Steel.
- *Note: Open Corners & Open Corrugated Ends,
Unit Will Not Hold Liquids or Material
Smaller Than a 5/8" Ball Bearing.

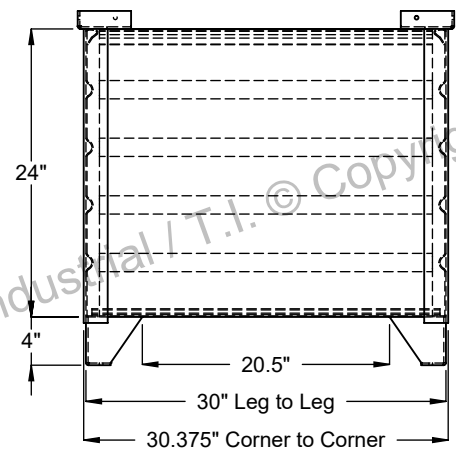

PROPRIETARY AND CONFIDENTIAL: THIS DRAWING AND INFORMATION CONTAINED IN THIS DRAWING IS THE SOLE PROPERTY OF GLOBAL INDUSTRIAL'S VENDOR/MFR. T.I. ANY REPRODUCTION IN PART OR AS A WHOLE WITHOUT THE WRITTEN PERMISSION OF GLOBAL INDUSTRIAL AND ITS VENDOR/MANUFACTURER T.I. IS PROHIBITED.

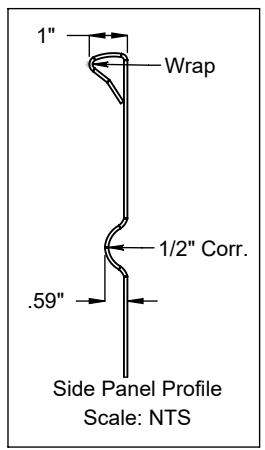
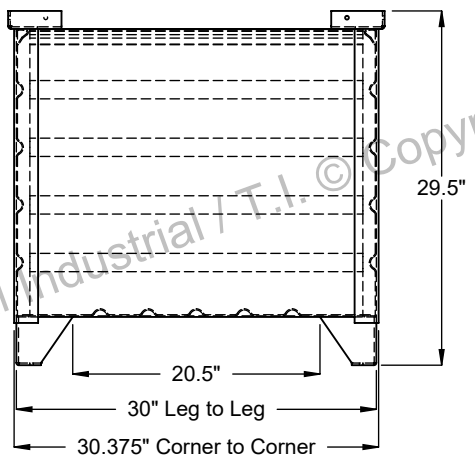

Global Item Number:
800100

Job Description:
Global Contact: www.Globalindustrial.com (800) 645-2986

Dwn by: Date Printed:
Apvrd by: Date Approved:
Last Saved By Date:

DECIMAL TOLERANCE AND UNITS
± .188 UNLESS NOTED
ALL DIMENSION ARE IN INCHES
Angle Tolerance
X° ± 1°
Prepared For:
Global Industrial

Mfr. Part Number:
51016

Global Part Number:
51016