









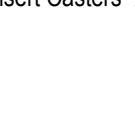

ASSEMBLY INSTRUCTIONS

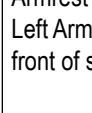
ITEM NO.: 695487

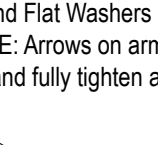
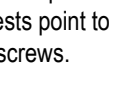
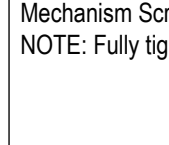
| Part List | | | |
|-----------|---|------|---|
| Key | Description | Qty. | Part |
| A | CASTERS | 5 |  |
| B | BASE | 1 |  |
| C | SEAT CUSHION | 1 |  |
| D | RIGHT ARMREST | 1 |  |
| E | LEFT ARMREST | 1 |  |
| F | ARMREST SCREWS D 1/4" x L 1 3/8" | 6 |  |
| G | FLAT WASHERS | 6 |  |
| H | MECHANISM | 1 |  |
| I | MECHANISM SCREWS D 5/16" x L 7/8" | 4 |  |
| J | BACK SUPPORT | 1 |  |
| K | BACK SUPPORT SCREWS D 5/16" x L 5/8" | 3 |  |
| L | ALLEN WRENCH | 1 |  |
| M | GAS LIFT | 1 |  |

Step 1
 Turn Base "B" upside down.
 Insert Casters "A" into Base "B".

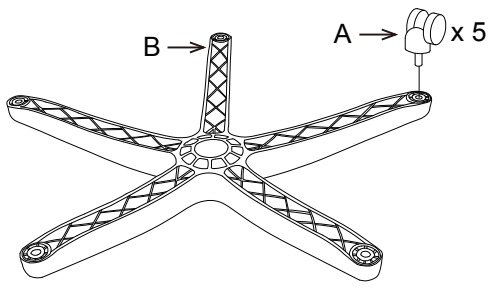

Step 4
 Attach Back Support "J" to the rear of Mechanism "H" with Back Support Screws "K".
 NOTE: Fully tighten all screws.

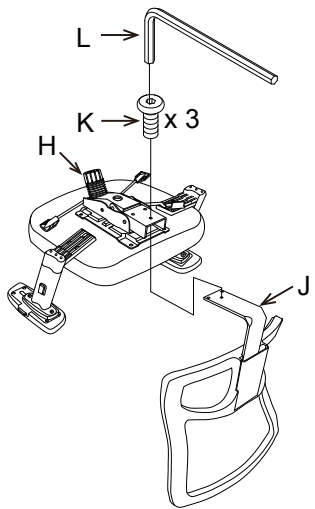

Step 2
 Attach Right Armrest "D" to Seat Cushion "C" with Armrest Screws "F" and Flat Washers "G". Repeat for Left Armrest "E". NOTE: Arrows on armrests point to front of seat cushion and fully tighten all screws.

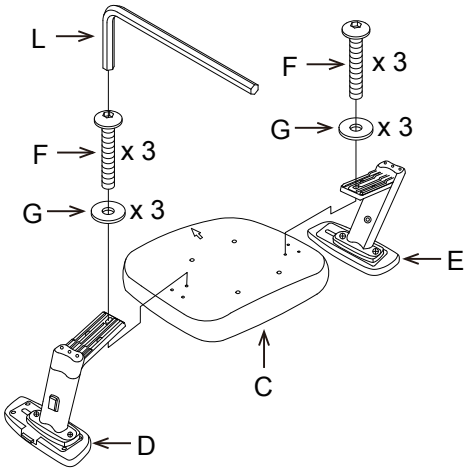

Step 5
 Insert Gas Lift "M" into hole on Base "B".

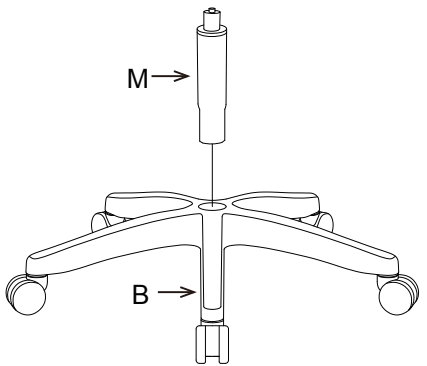

Step 3
 Attach Mechanism "H" to Seat Cushion "C" with Mechanism Screws "I".
 NOTE: Fully tighten all screws.

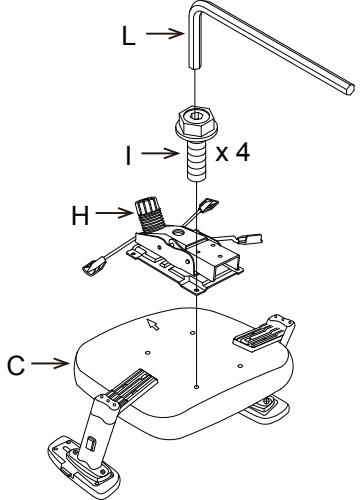

Step 6
 Place seat assembly onto Gas Lift "M". Push firmly on the chair seat to securely attach seat assembly to seat post.

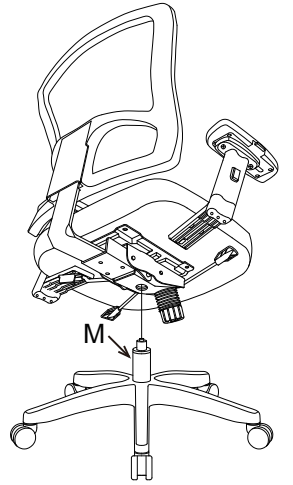

ATTENTION: Make certain that all screws are fully tightened before using chair. Lubricate all moving parts and tighten all screws every 6 months or as needed.