

SAFETY-VIEW PLUS K. D. 6-TIER STOCK LOCKER ASSEMBLY INSTRUCTIONS

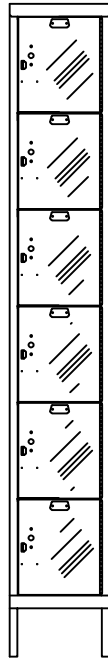

1 WIDE
6 TIER
FRONT VIEW

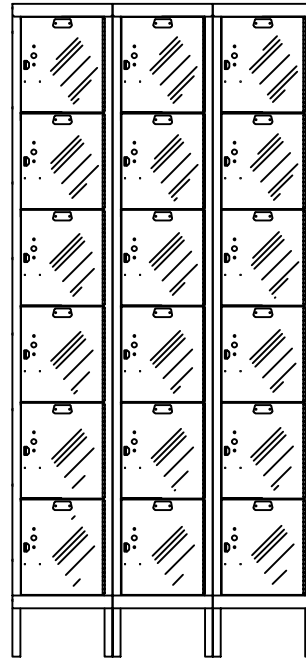

3 WIDE
6 TIER
FRONT VIEW

General Instructions

1. Check material received against the packing list. First check the number of packages received and then check the contents of each package.
2. Check material received for damage. If damage has occurred, secure a "damage notation" from the carrier.
3. Identify each part as it is unpacked and put like parts together as close as possible to the working area in which they are to be assembled.
4. Be careful to use the correct hardware as specified in the assembly instructions.
5. Items with suffix (xx) are available options.

CAUTION

IN THE INTEREST OF SAFETY, ALL LOCKERS MUST BE SECURELY ANCHORED TO THE FLOOR AND/OR WALL.
FOR SAFETY, HANDLE ALL COMPONENTS CAREFULLY AND WEAR WORK-GLOVES WHEN ASSEMBLING LOCKERS.
INSTALL ALL UNITS PLUMB AND TIGHTEN ALL HARDWARE SECURELY.
RETAIN INSTRUCTIONS FOR FUTURE REFERENCE.

SAFETY-VIEW PLUS K.D. 6-TIER STOCK LOCKER ASSEMBLY INSTRUCTIONS

6-TIER PACKAGE CONTENTS

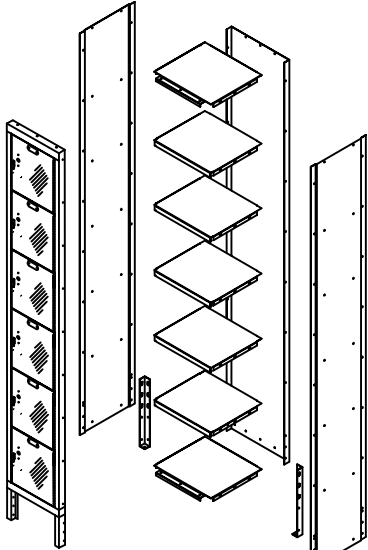
REF. NO.	DESCRIPTION	PART NO.	1 WIDE QUANTITY 6 TIER		3 WIDE QUANTITY 6 TIER		 <p style="text-align: center;">1-Wide 6-Tier KD Locker</p>
①	REAR PANEL	KRww72	1		3		
②	RIGHT/LEFT SIDE PANEL	KPdd72	2		4		
③	TOP/BOTTOM SHELF	KSwwdd	2		6		
④	INTERMEDIATE SHELF	KHwwdd	5		15		
⑤	DOOR FRAME ASSEMBLY	LKDFww78-6SVP	1		3		
× ⑥	DOOR	LKDww72-6SVP	6		18		
⑦	BOX DOOR LATCH PULL	KBLP100	6		18		
⑧	NUMBER PLATE	NPG100	6		18		
⑨	NUMBER PLATE RIVET	RV101P	12		36		
⑩	REAR LEG	KLG	2		2		
⑪	3/8" SLOTLESS BOLT	MBT200	94		282		
⑫	HEX NUT	N201	82		246		
⑬	HI-DOME CAP NUT	N110	12		36		
× ⑭	PIANO HINGE	×PH11	6		18		
× ⑮	RIVET (HINGE)	RV102	12		36		

PART NUMBER SUFFIX SHOW
WIDTH, DEPTH, HEIGHT AND TIER
CUSTOMER TO SPECIFY.

NOTE:

FOR OPTIONAL INDIVIDUAL SLOPE TOPS,
SEE SUPPLEMENTAL INSTRUCTION SHEET NO. ASY-L-KIST-A

FOR OPTIONAL 6" HIGH CLOSED METAL BASE,
SEE SUPPLEMENTAL INSTRUCTION SHEET NO. ASY-L-KIST-B

× SHIPS PRE-HUNG IN FRAME ASSEMBLY.

PART NO. LEGEND:

dd = DEPTH
ww = WIDTH

**TOOLS REQUIRED: 3/8" NUT
DRIVER (3/8" SOCKET MAY BE
SUBSTITUTED)**

TWO-YEAR WARRANTY

LOCKERS ARE COVERED AGAINST ALL DEFECTS IN MATERIALS AND WORKMANSHIP EXCLUDING FINISH, DAMAGE RESULTING FROM DELIBERATE DESTRUCTION AND VANDALISM UNDER THIS SECTION FOR A PERIOD OF TWO YEARS.

SAFETY-VIEW PLUS K.D. 6TIER STOCK LOCKER ASSEMBLY INSTRUCTIONS

(A GROUPING OF (3) THREE 6-TIER LOCKERS ILLUSTRATED)

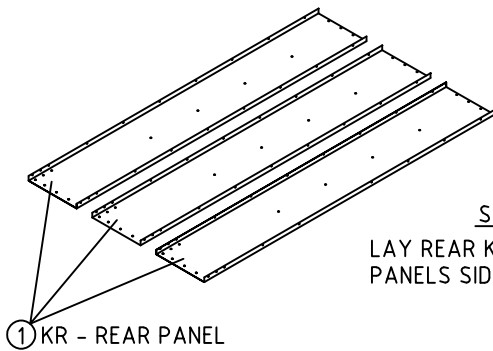

STEP 1
LAY REAR KR ①
PANELS SIDE BY SIDE.

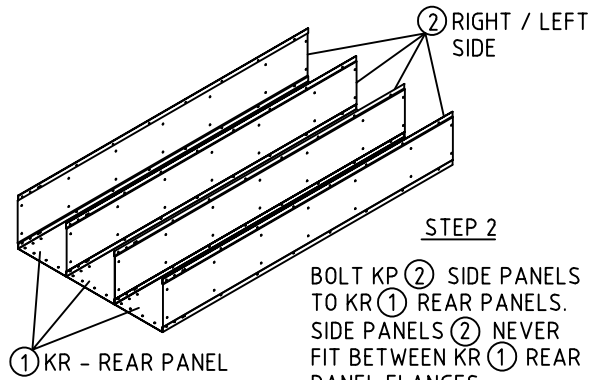

STEP 2
BOLT KP ② SIDE PANELS
TO KR ① REAR PANELS.
SIDE PANELS ② NEVER
FIT BETWEEN KR ① REAR
PANEL FLANGES.

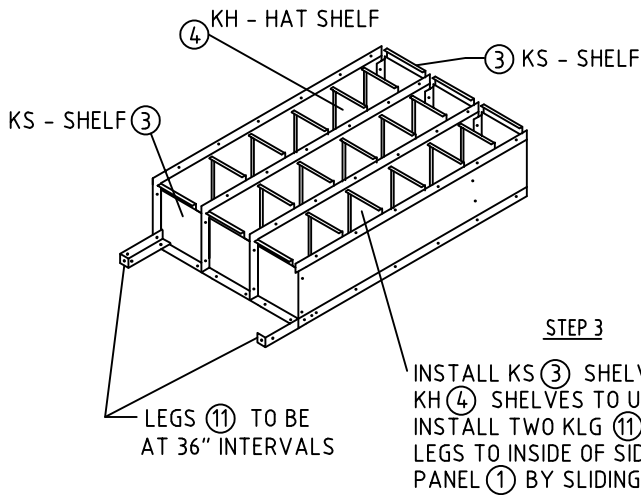

STEP 3
INSTALL KS ③ SHELVES AND
KH ④ SHELVES TO UNIT.
INSTALL TWO KLG ⑪ REAR
LEGS TO INSIDE OF SIDE ②
AND REAR
PANEL ① BY SLIDING INTO PLACE FROM BOTTOM.

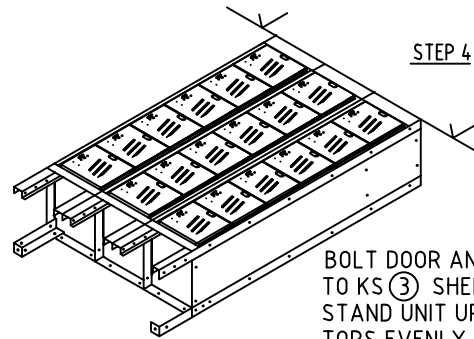

STEP 4
BOLT DOOR AND FRAME ⑤ ASSEMBLIES
TO KS ③ SHELVES AND KP ② SIDE PANELS.
STAND UNIT UP AND ALIGN LOCKER
TOPS EVENLY. TIGHTEN ALL BOLTS
AND NUTS.
NOTE: WHEN BOLTING ONE UNIT TO
ANOTHER, OMIT ONE SET OF BOLTS
IN END FRAME AND SIDE TO MINIMIZE
GROWTH FROM BOLT HEADS.

ASSEMBLY OF SINGLE ROW LOCKERS NEVER PUT SIDE PANELS BETWEEN FRAMES.

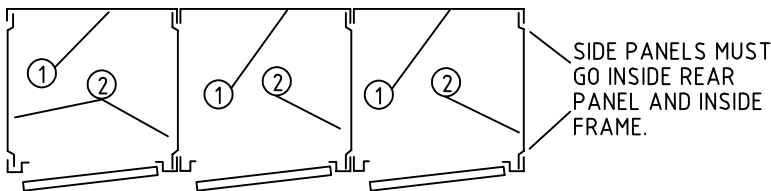

3 WIDE UNIT PLAN VIEW

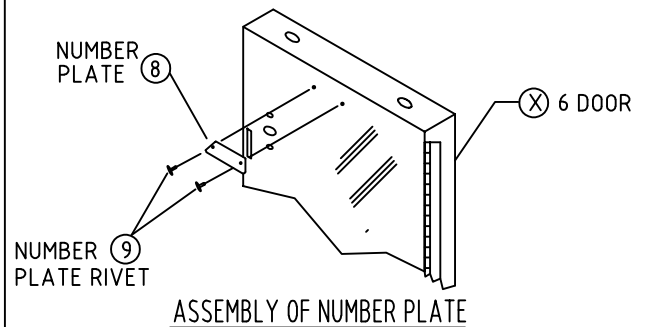

ASSEMBLY OF NUMBER PLATE

HARDWARE USED FOR MAIN LOCKER ASSEMBLY

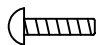

10 - 24 x 3/8"

MBT200 SLOTLESS BOLT ⑪



N201 HEX NUT ⑫

TIGHTEN NUT WITH A NUT DRIVER OR WRENCH
(SCREW IS TAMPER RESISTANT).

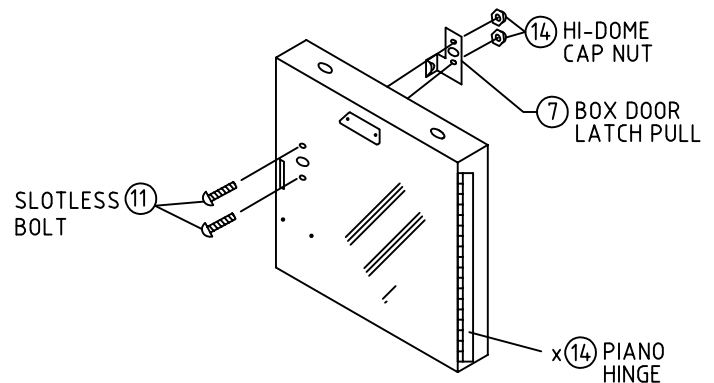

ASSEMBLY OF LATCH PULL