

MODEL 269872 (36"W x 24"D x 42"H)
 269870 (36"W x 18"D x 42"H)
 298680 (36"W x 18"D x 42"H)
 298681 (36"W x 24"D x 42"H)

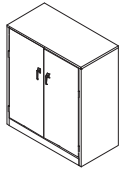









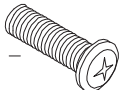



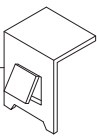

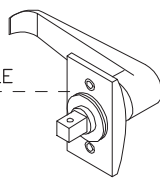
www.globalindustrial.com
 1-800-645-2986

INDUSTRIAL STORAGE CABINET
 ASSEMBLY INSTRUCTION

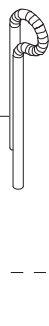
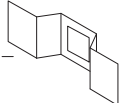

CONTENTS

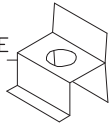
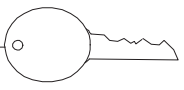
REF	QTY	DESCRIPTION	REF	QTY	DESCRIPTION
1	1	LEFT SIDE BACK PANEL	H1	4	M6X19mm ROUND PHILLIP HEAD SCREW 
2	1	RIGHT SIDE BACK PANEL	H2	4	6.5mm PLATE WASHER 
3	1	LEFT SIDE PANEL	H3	4	
4	1	RIGHT SIDE PANEL	H4	2	BUMPER 
5	1	INNER SUPPORT BAR	H5	8	HINGE PIN 
6	1	OUTER SUPPORT BAR	H6	8	SHELF CLIP 
7	1	BASE	H7	6	PLASTIC INSERT 
8	1	TOP	H8	1	RIGHT HAND DOOR HANDLE 
9	1	LEFT DOOR	H9	2	BACK PLATE 
10	1	RIGHT DOOR	H10	4	5.5mm SPLIT WASHER 
11	2	SHELF	H11	4	M5X8mm ROUND PHILLIP HEAD SCREW 
			H12	1	COTTER PIN 
			H13	1	LOCK LATCH 
			H14	2	LOCKING ROD 
			H15	1	LOCKING BRACKET 
			H16	1	LEFT HAND DOOR HANDLE 
			H17	2	ROD GUIDE 
			2	KEY 	



WARNING.

1. USE 2 PEOPLE TO ASSEMBLE.
2. LAY PARTS ON SOFT SMOOTH NON-SCRATCH SURFACE.
3. DO NOT OVERLOAD SHELVES.
4. LOAD LOWER SHELF FIRST.
5. DO NOT CLIMB OR STAND ON SHELVES.

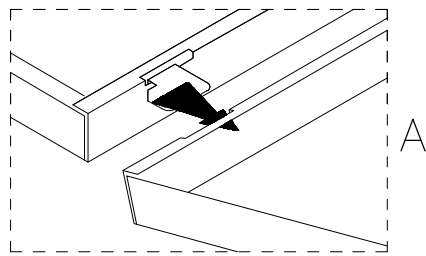

SEE DETAIL A and B

1

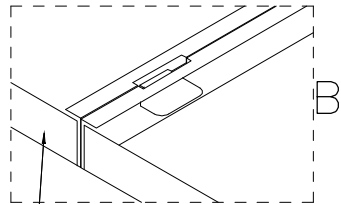

1

1

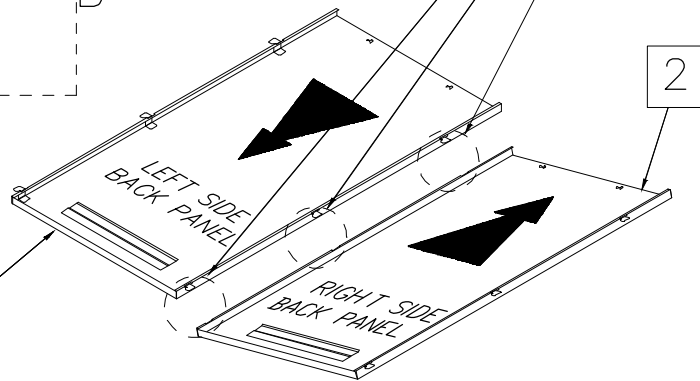

2

SEE DETAIL C and D

2

3

4

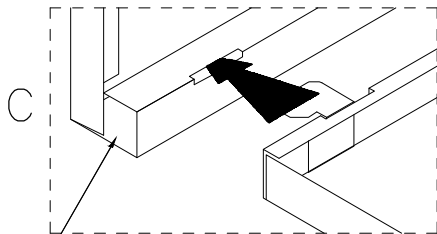

3

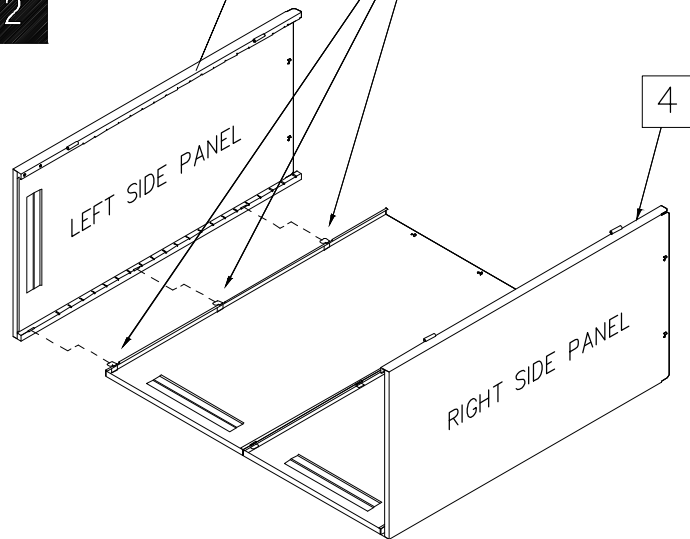

D

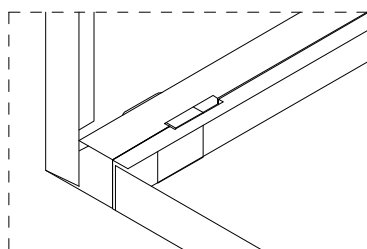

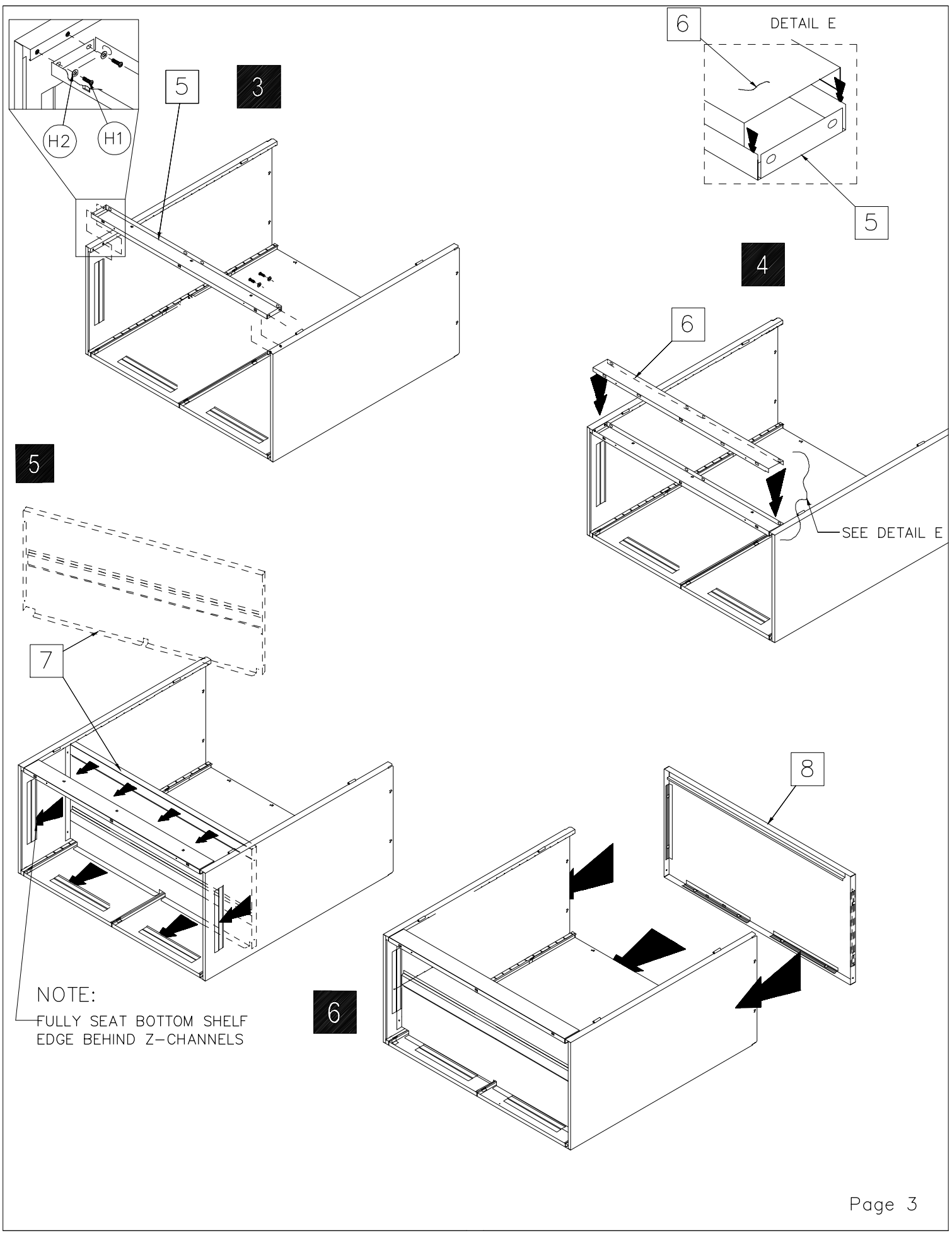

NOTE:
 FULLY SEAT BOTTOM SHELF
 EDGE BEHIND Z-CHANNELS

7

STAND CABINET UP.
(2 PEOPLE REQUIRED)

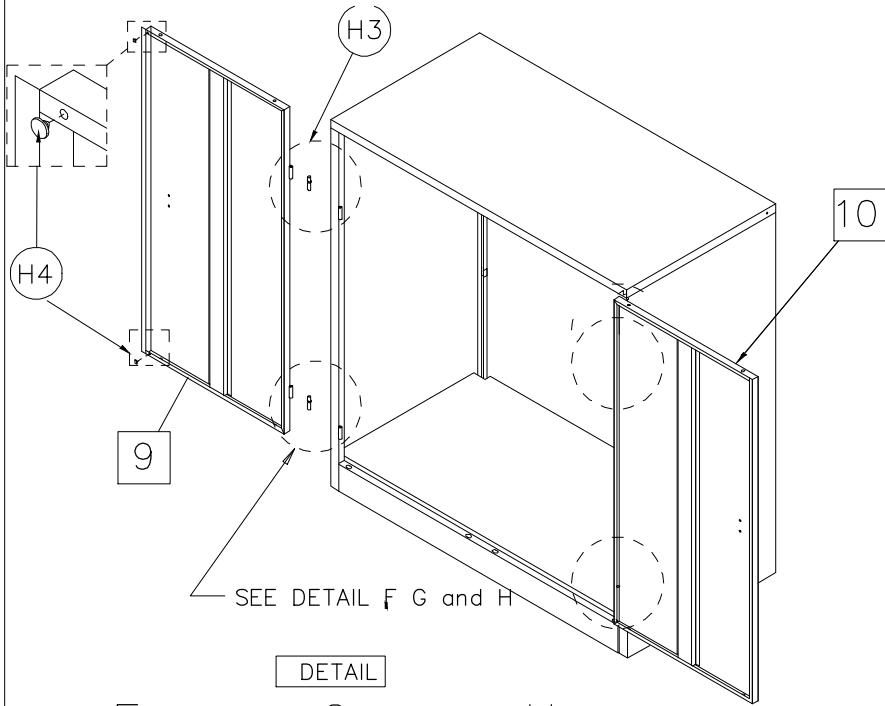

8

SEE DETAIL I and J

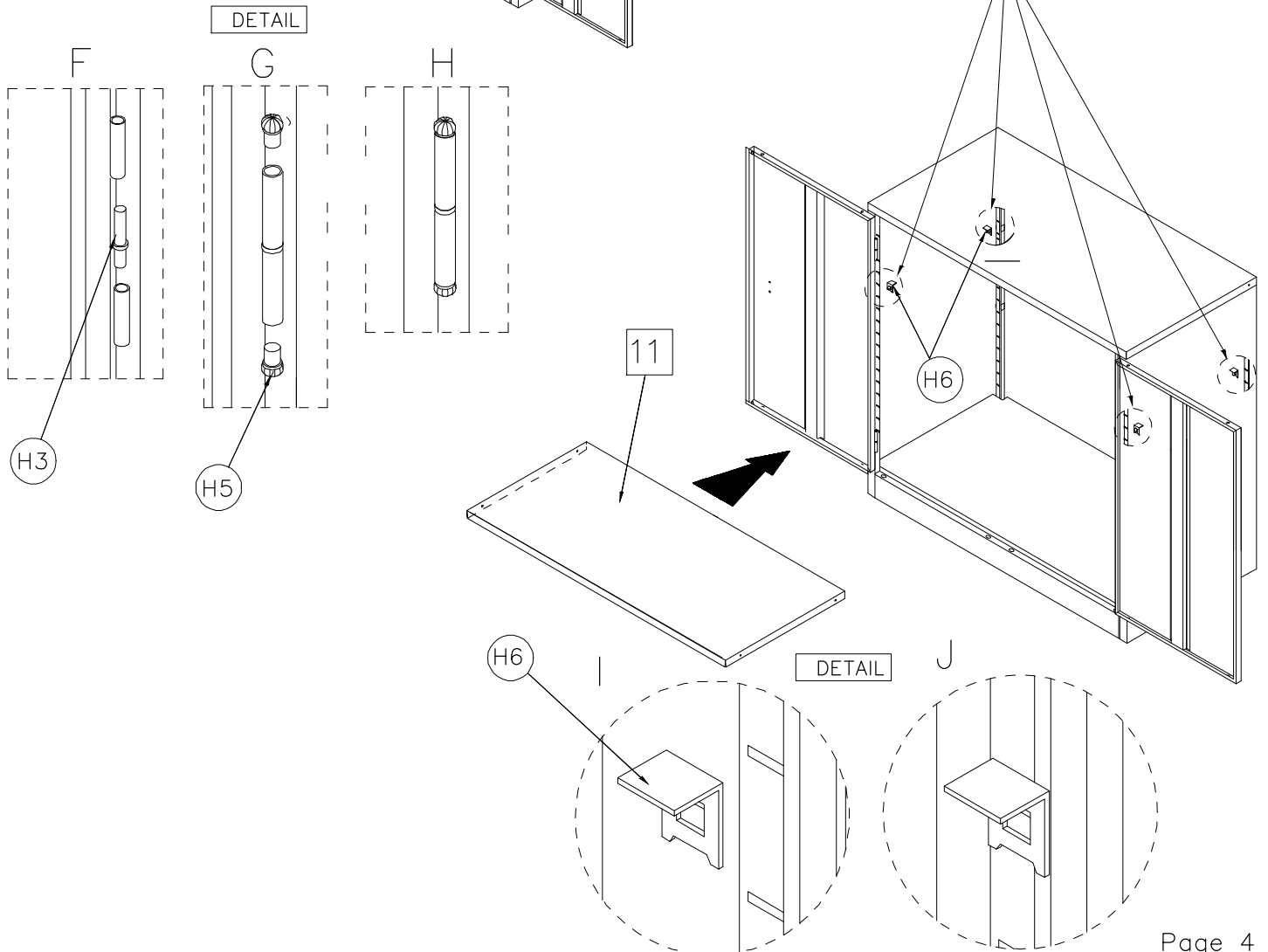

9

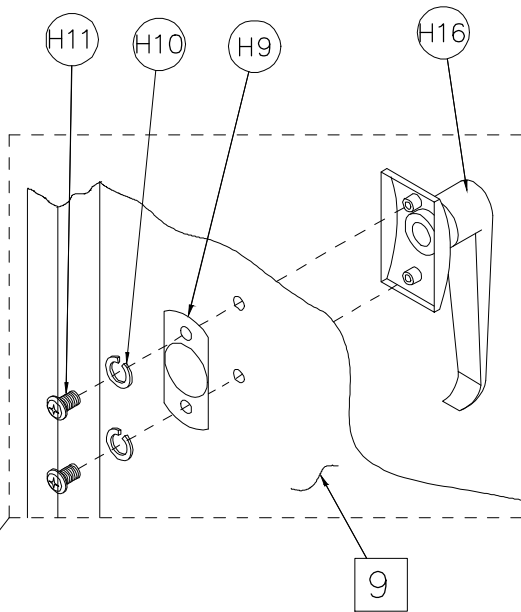

9

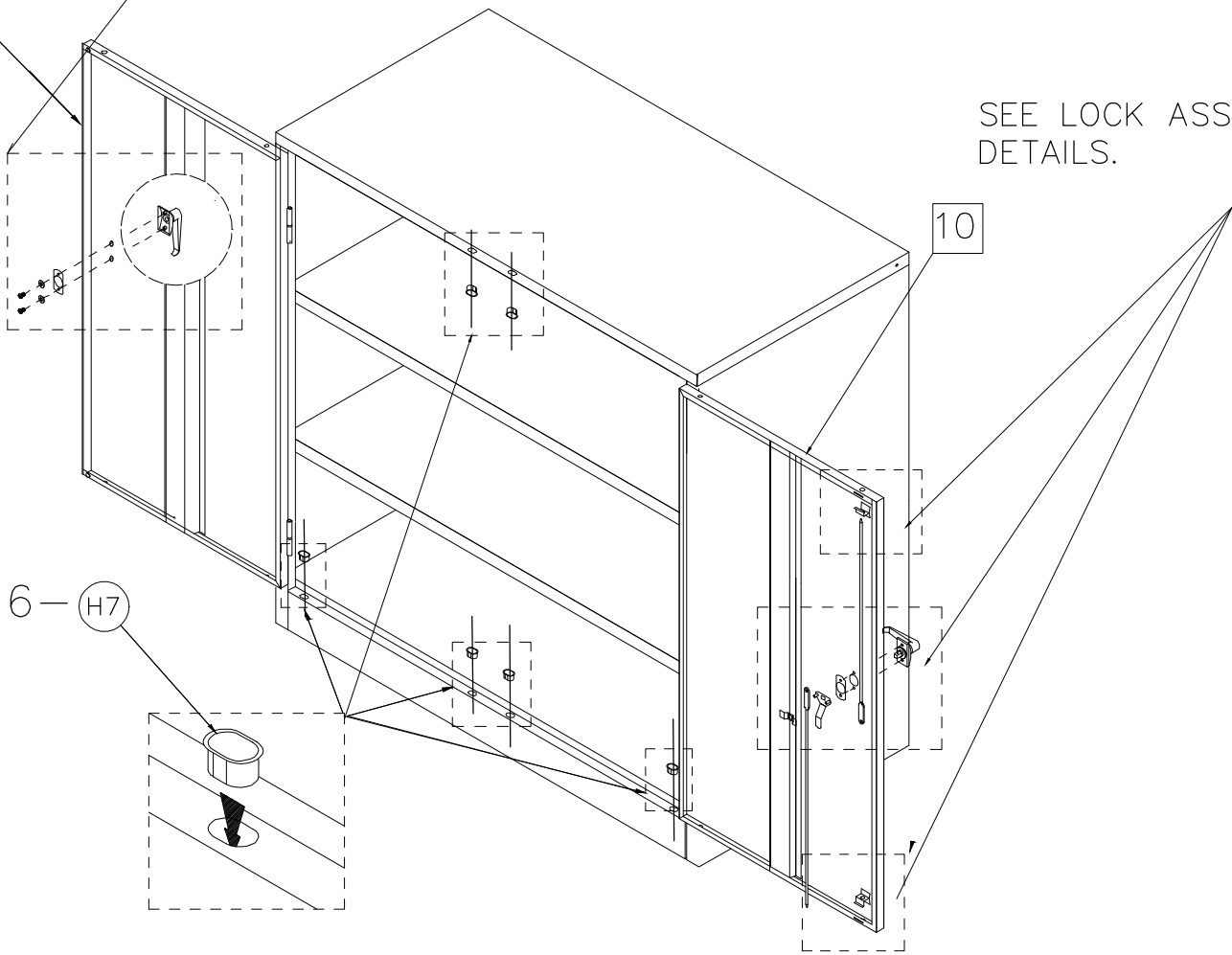

SEE LOCK ASSEMBLY
DETAILS.

LOCK ASSEMBLY

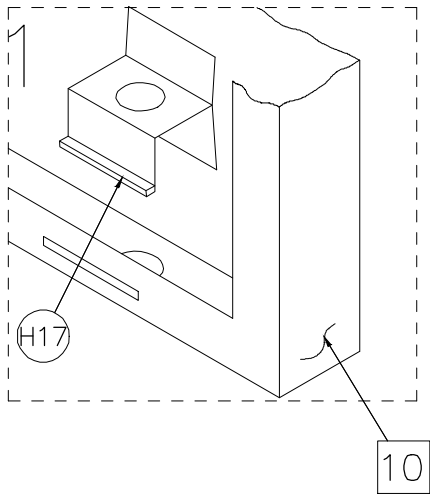

RIGHT DOOR ROD ASSEMBLY

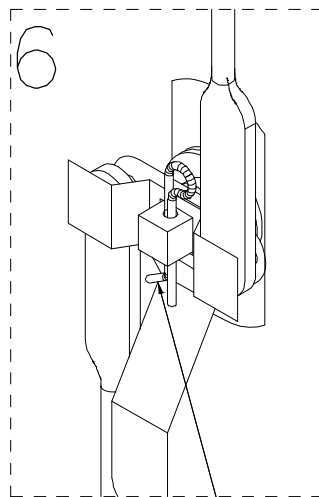
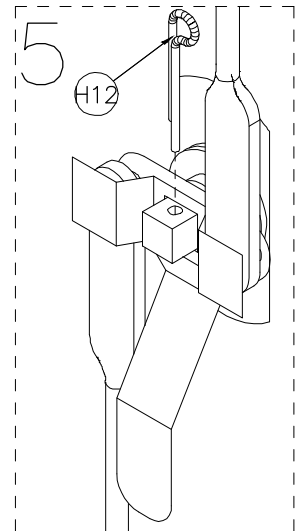
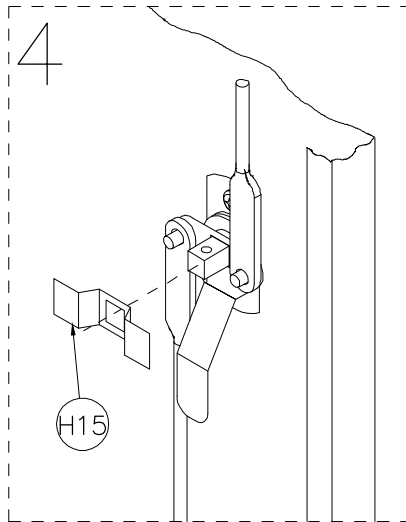
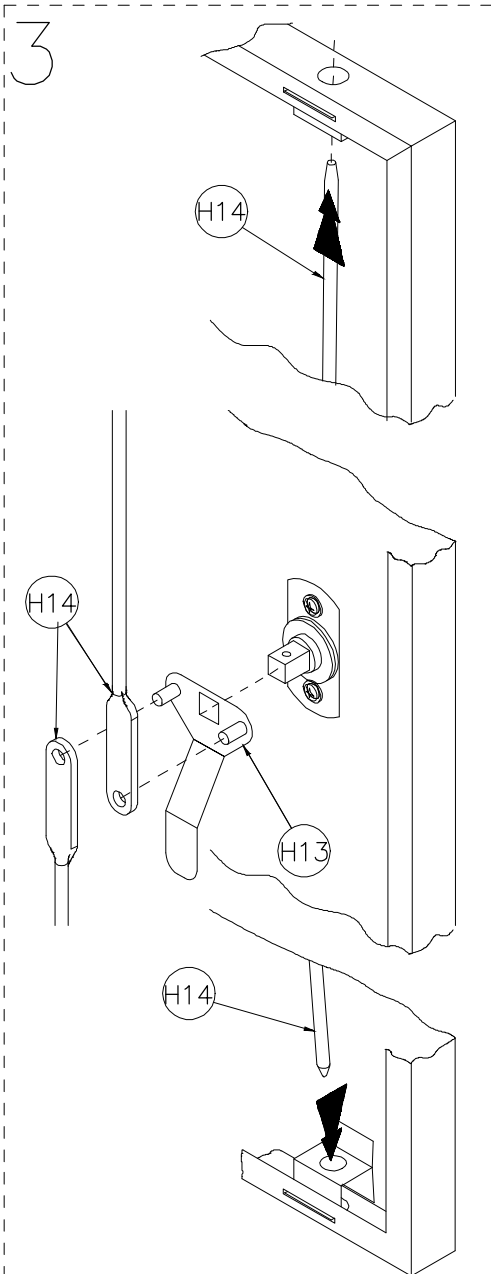
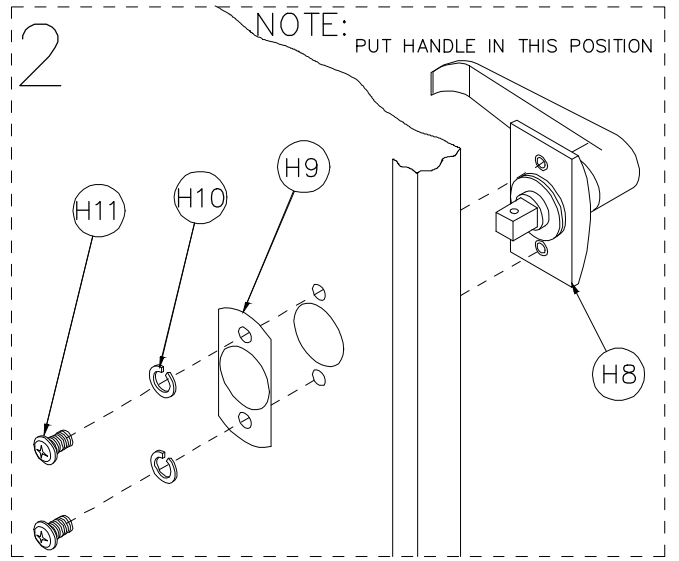

BEND 1 LEG OF
COTTER PIN WITH PLIERS.