

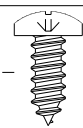







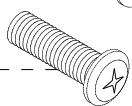
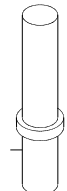

# CONTENTS

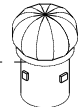
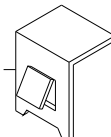
REF.	QTY.	DESCRIPTION	REF.	QTY.	DESCRIPTION
1	1	LEFT SIDE BACK PANEL	H1	10	SHEET METAL 
2	1	RIGHT SIDE BACK PANEL	H2	4	6.5 PLAIN WASHER 
3	1	LEFT SIDE PANEL	H3	4	5.25 mm SPLIT WASHER 
4	1	RIGHT SIDE PANEL	H4	4	M6 x 19 mm ROUND PHILLIP HEAD SCREW 
5	1	BOTTOM FRONT INNER SUPPORT CHANNEL	H5	4	HINGE PIN 
6	1	BOTTOM FRONT KICK PLATE	H6	2	BUMPER 
7	1	BOTTOM SHELF	H7	8	PLASTIC HINGE CAP 
8	1	TOP SHELF	H8	8	SHELF CLIP 
9	1	LEFT DOOR	H9	6	PLASTIC INSERT 
10	1	RIGHT DOOR	H10	1	RIGHT HAND DOOR HANDLE 
11	2	SHELF	H11	2	BACK PLATE 
			H12	4	5.5mm SPLIT WASHER 
			H13	4	M5 x 8mm ROUND PHILLIP HEAD SCREW 
			H14	1	COTTER PIN 
			H15	1	LOCK LATCH 
			H16	2	LOCKING ROD 
			H17	1	LOCKING BRACKET 
			H18	1	LEFT HAND DOOR HANDLE 
			H19	2	ROD GUIDE 
			2	KEY 	

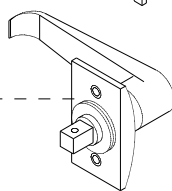

## WARNING.

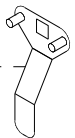
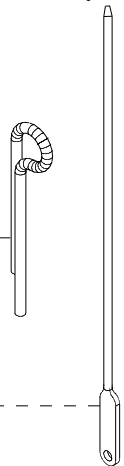
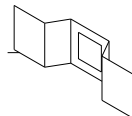
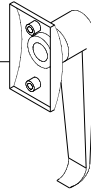
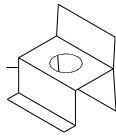
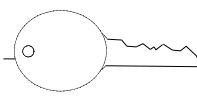
1. USE 2 PEOPLE TO ASSEMBLE.
2. LAY PARTS ON SOFT SMOOTH NON-SCRATCH SURFACE.
3. DO NOT OVERLOAD SHELVES.
4. LOAD LOWER SHELVES FIRST.
5. DO NOT CLIMB OR STAND ON SHELVES.

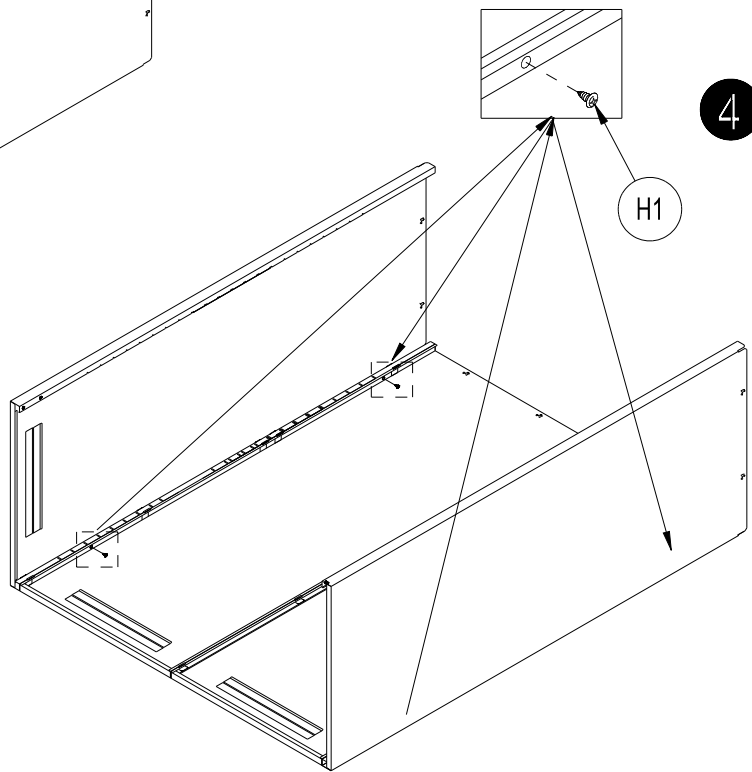
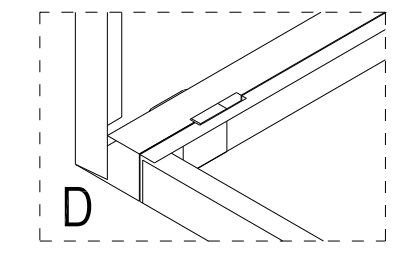
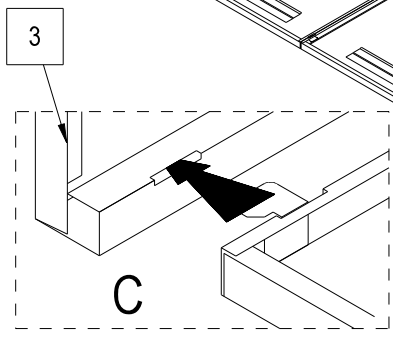
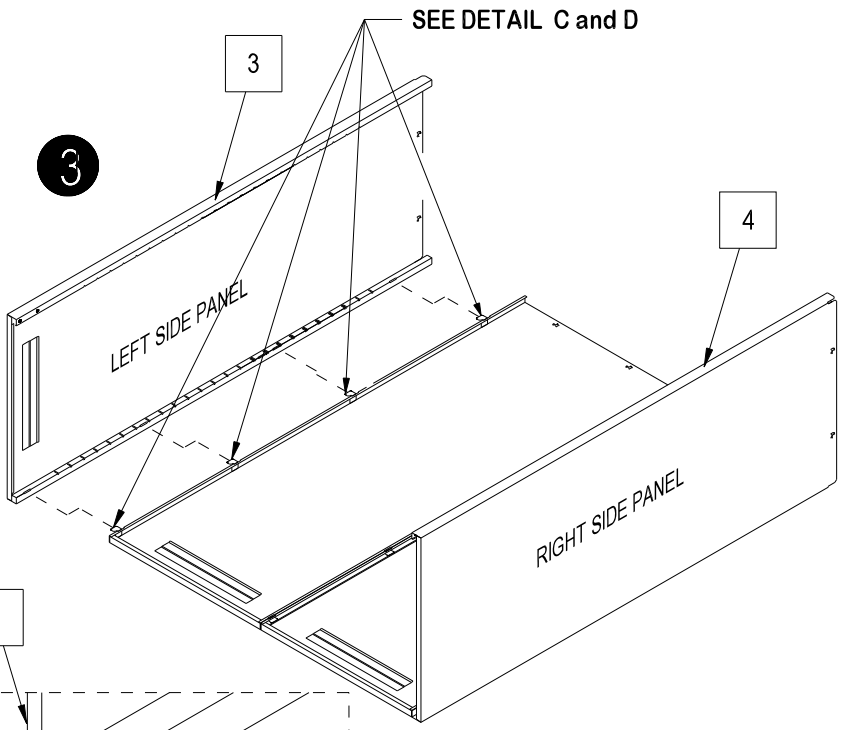
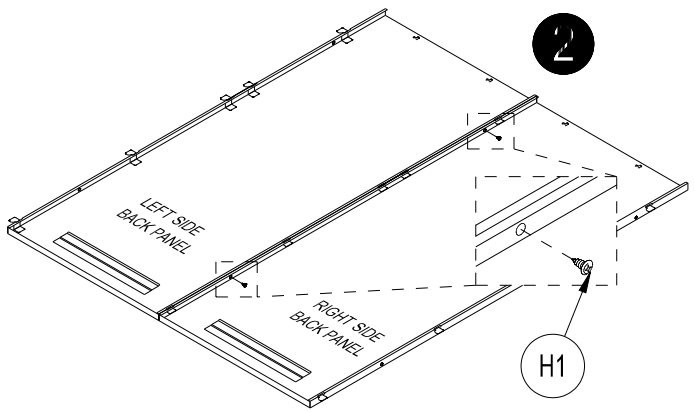
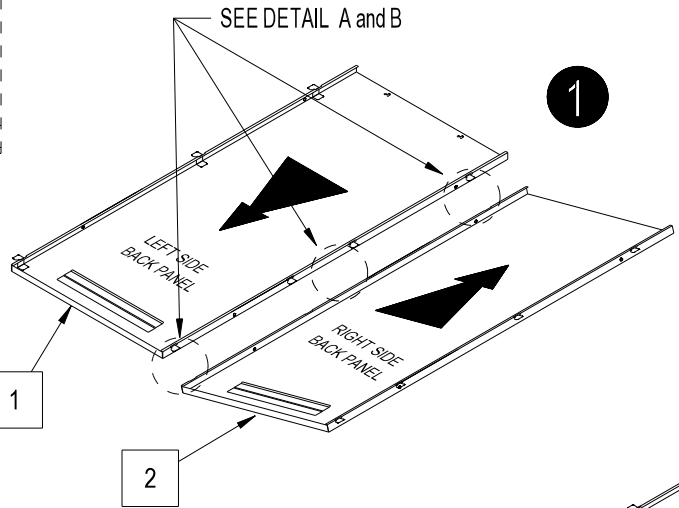
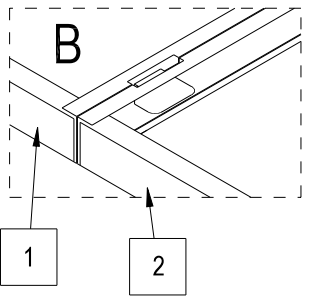
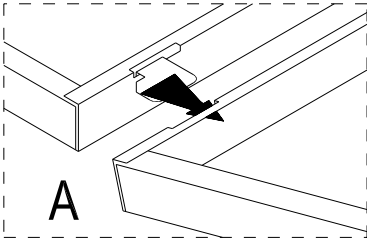

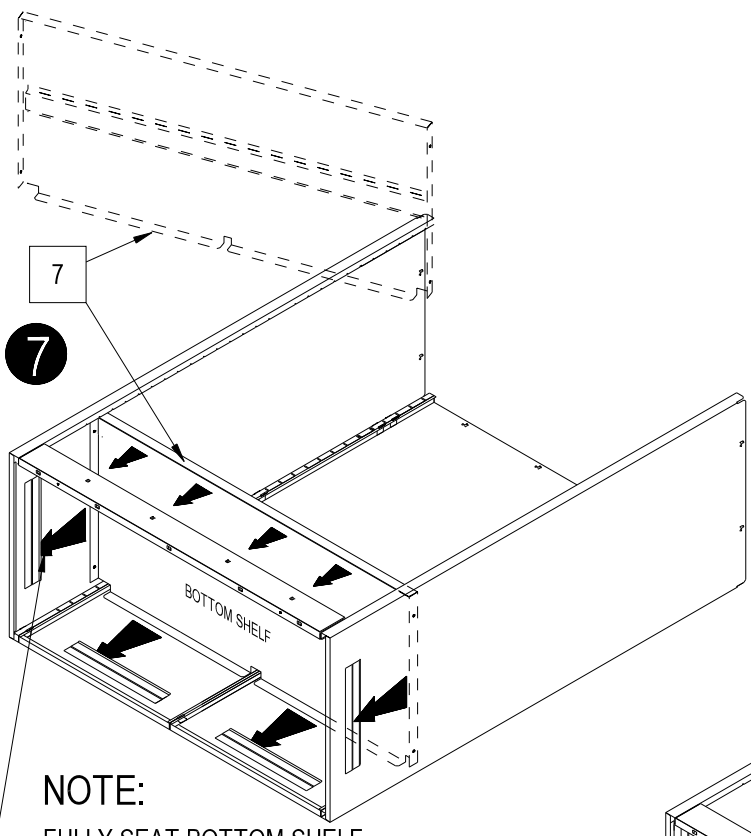
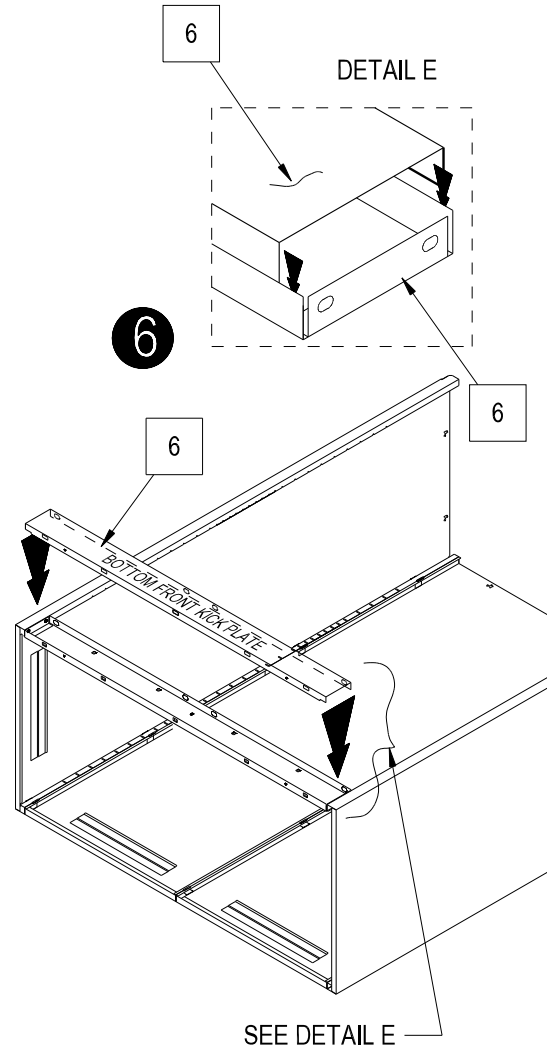
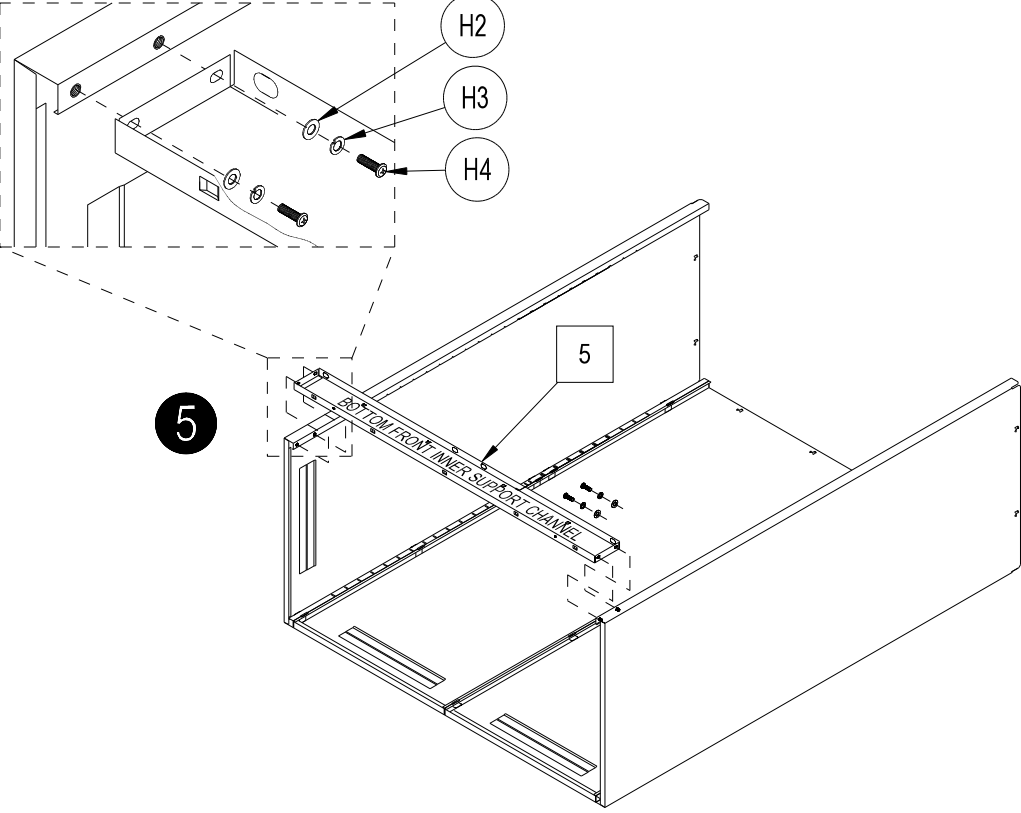

**NOTE:**  
FULLY SEAT BOTTOM SHELF  
EDGE BEHIND Z-CHANNELS

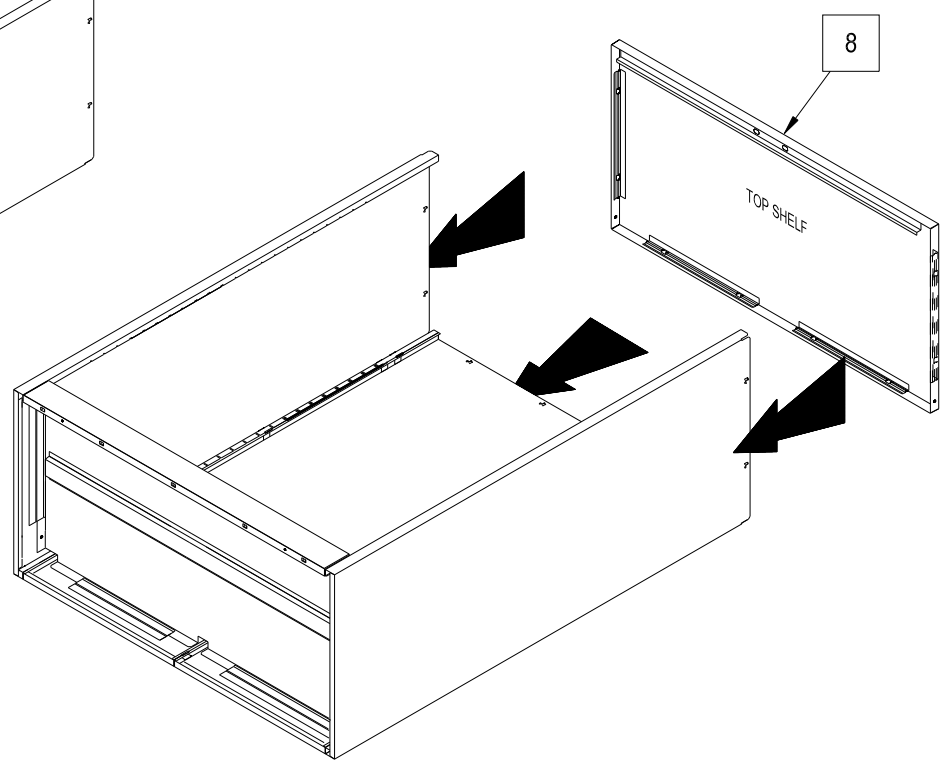

STAND CABINET UP.  
(2 PEOPLE REQUIRED)

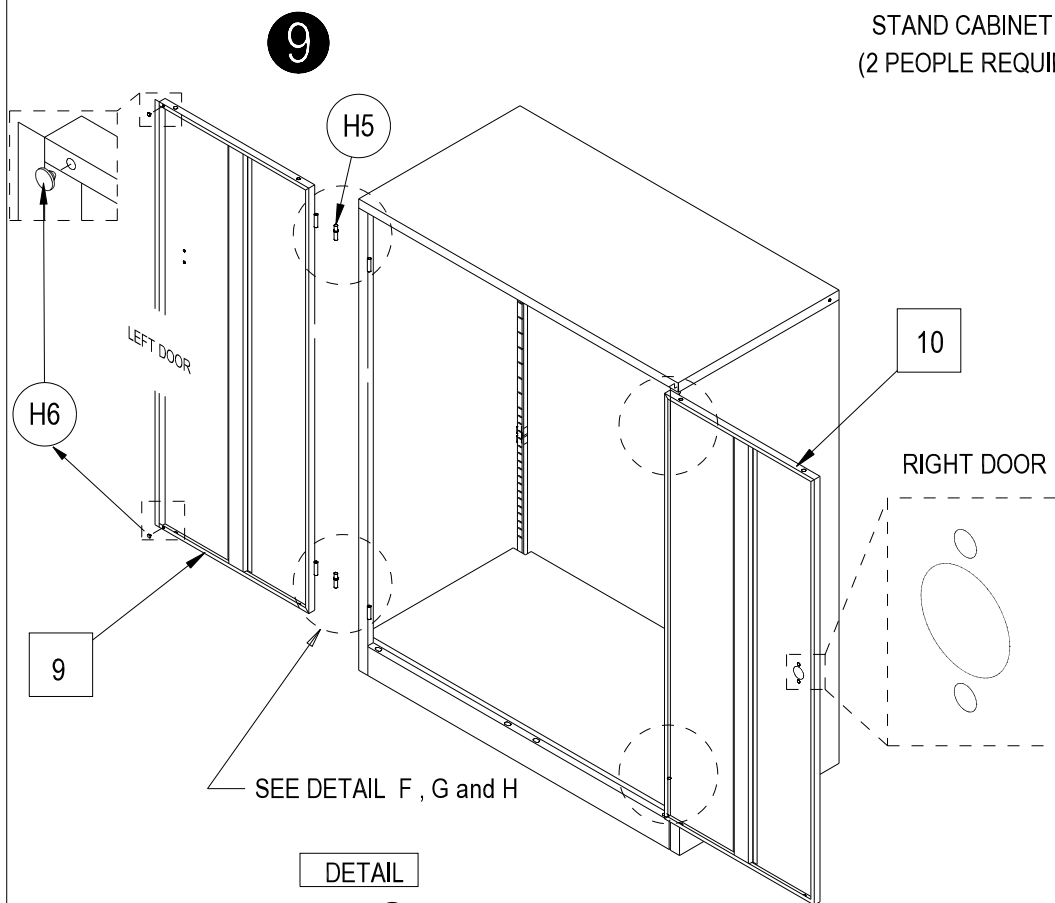

DETAIL

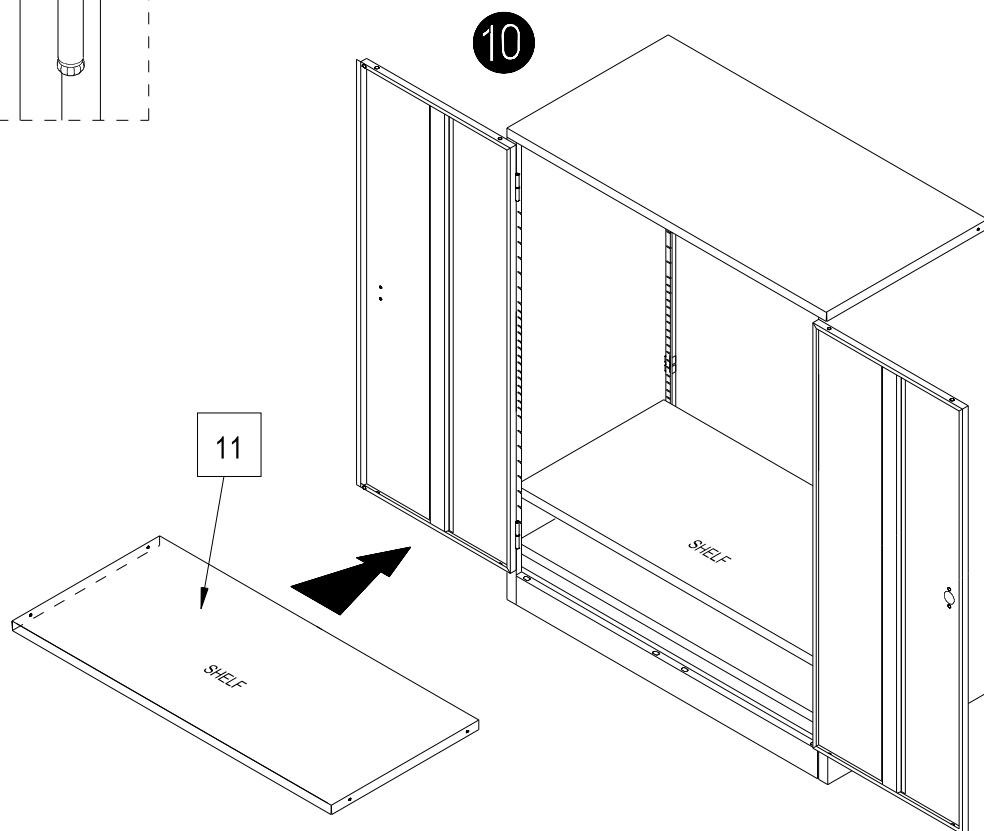
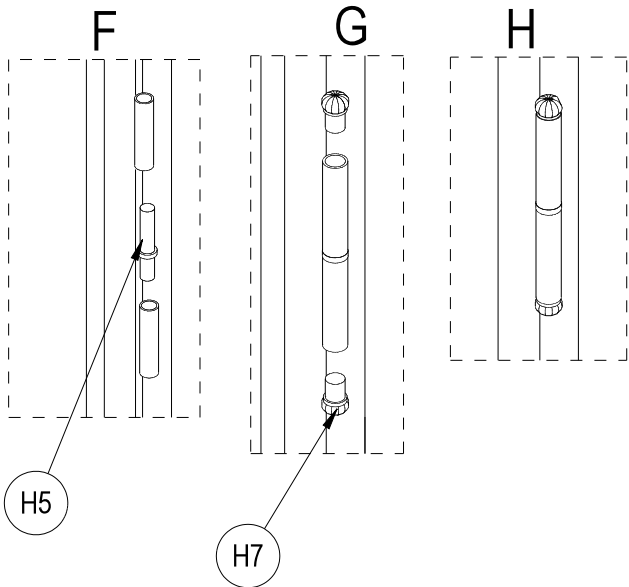

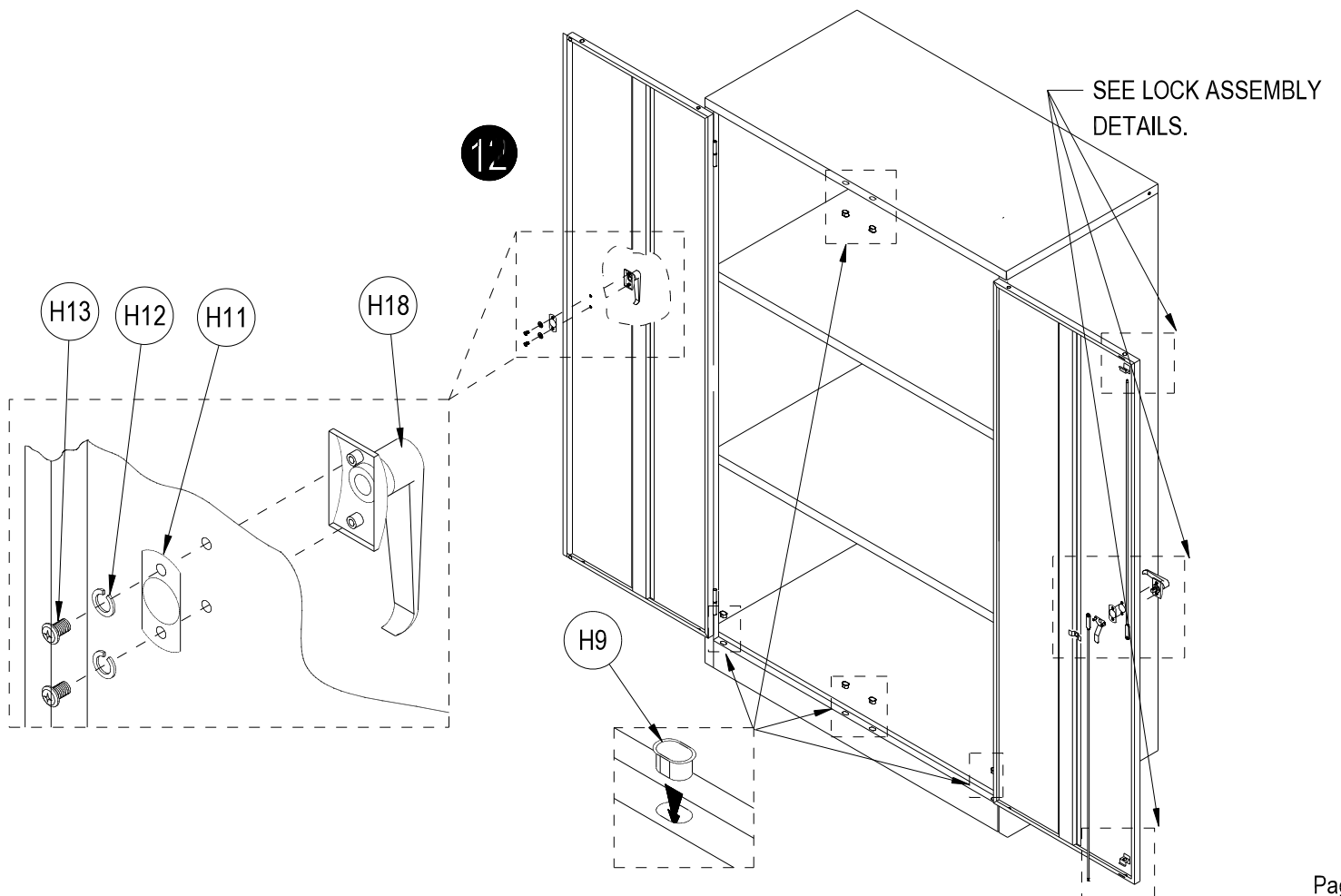
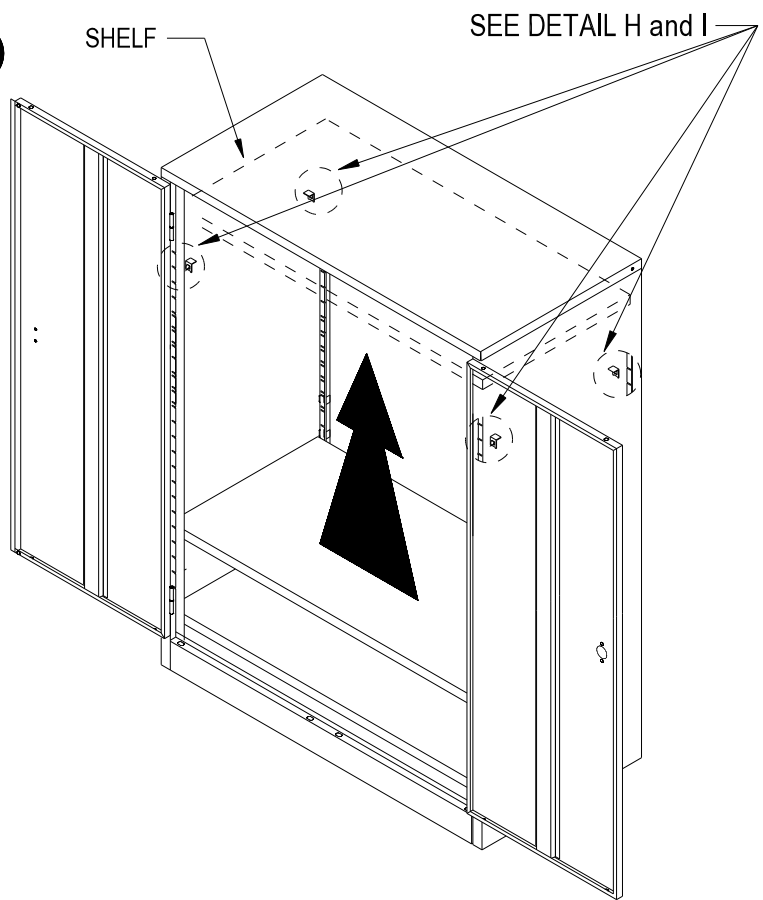
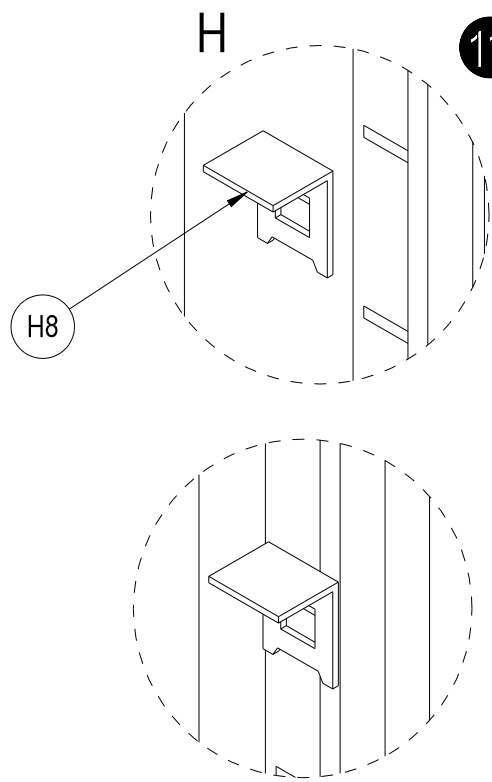

# LOCK ASSEMBLY

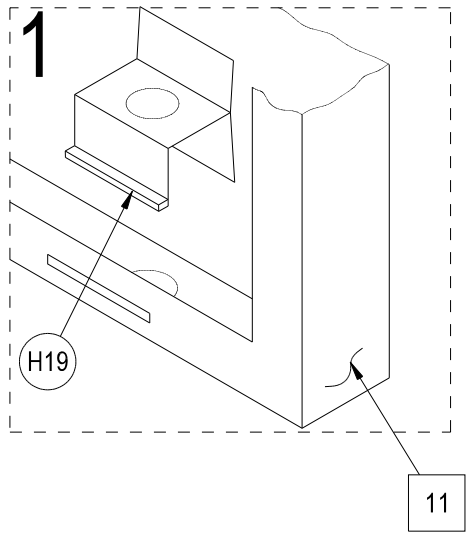

RIGHT DOOR ROD ASSEMBLY

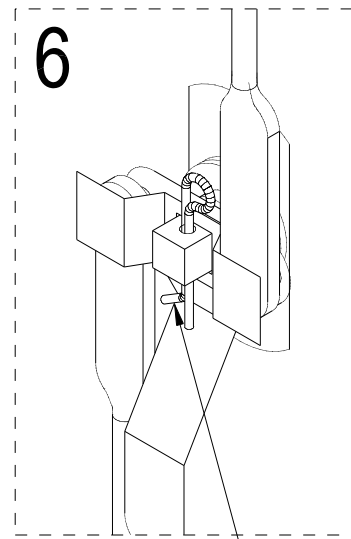
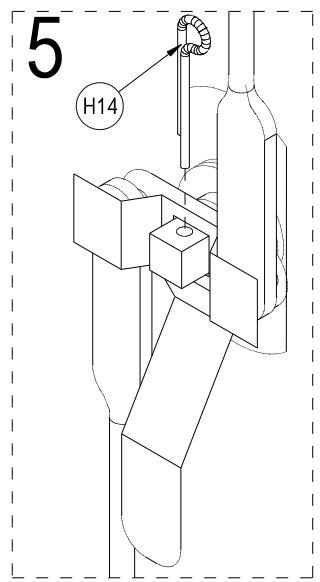
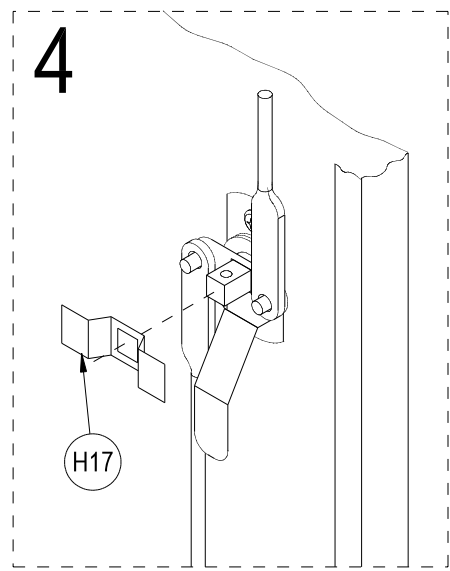
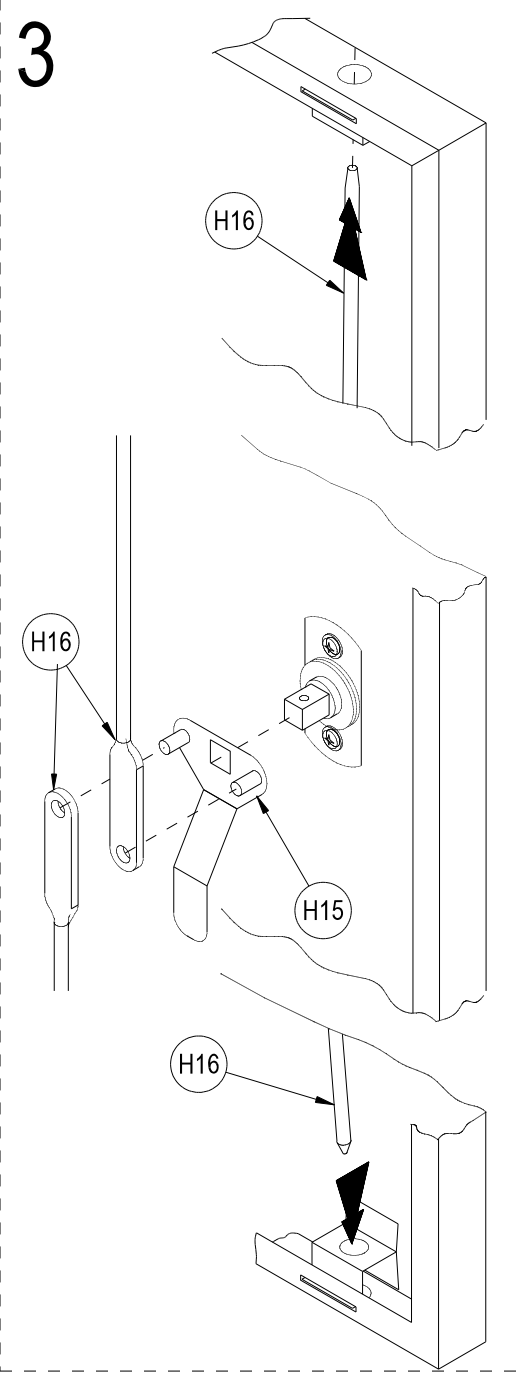
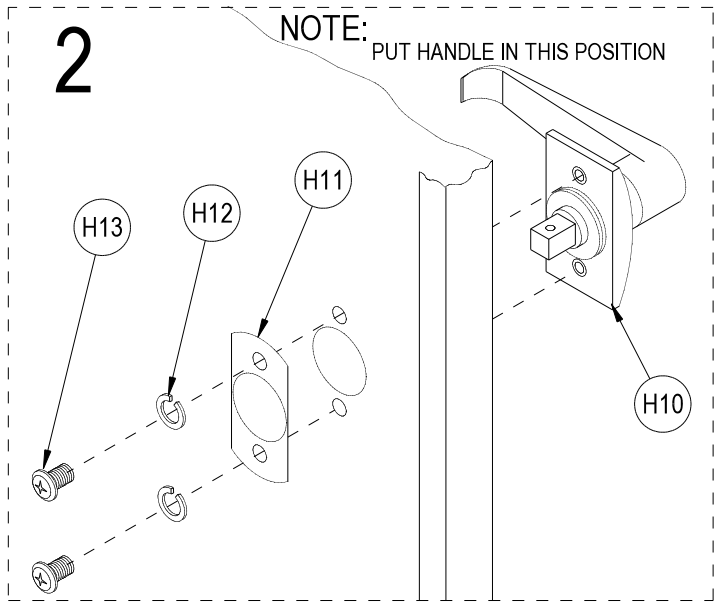

BEND 1 LEG OF COTTER PIN WITH PLIERS.