

STATIONARY HYDRAULIC DRUM DUMPER - HDD-48-7-S

APPROX WEIGHT: 675.26 lbs. DOES NOT INCLUDE WEIGHT OF POWER OR PACKAGING!!!

ANY ADDITIONS, DELETIONS, OR OMISSIONS MUST BE CORRECTED ON THIS DRAWING AS THIS DRAWING WILL BE CONSIDERED ALL INCLUSIVE

ALL GRAPHICS PROVIDED ARE FOR REFERENCE ONLY. IF CERTAIN DIMENSIONS ARE CRITICAL PLEASE VERIFY THOSE DIMENSIONS WITH YOUR SALESPERSON

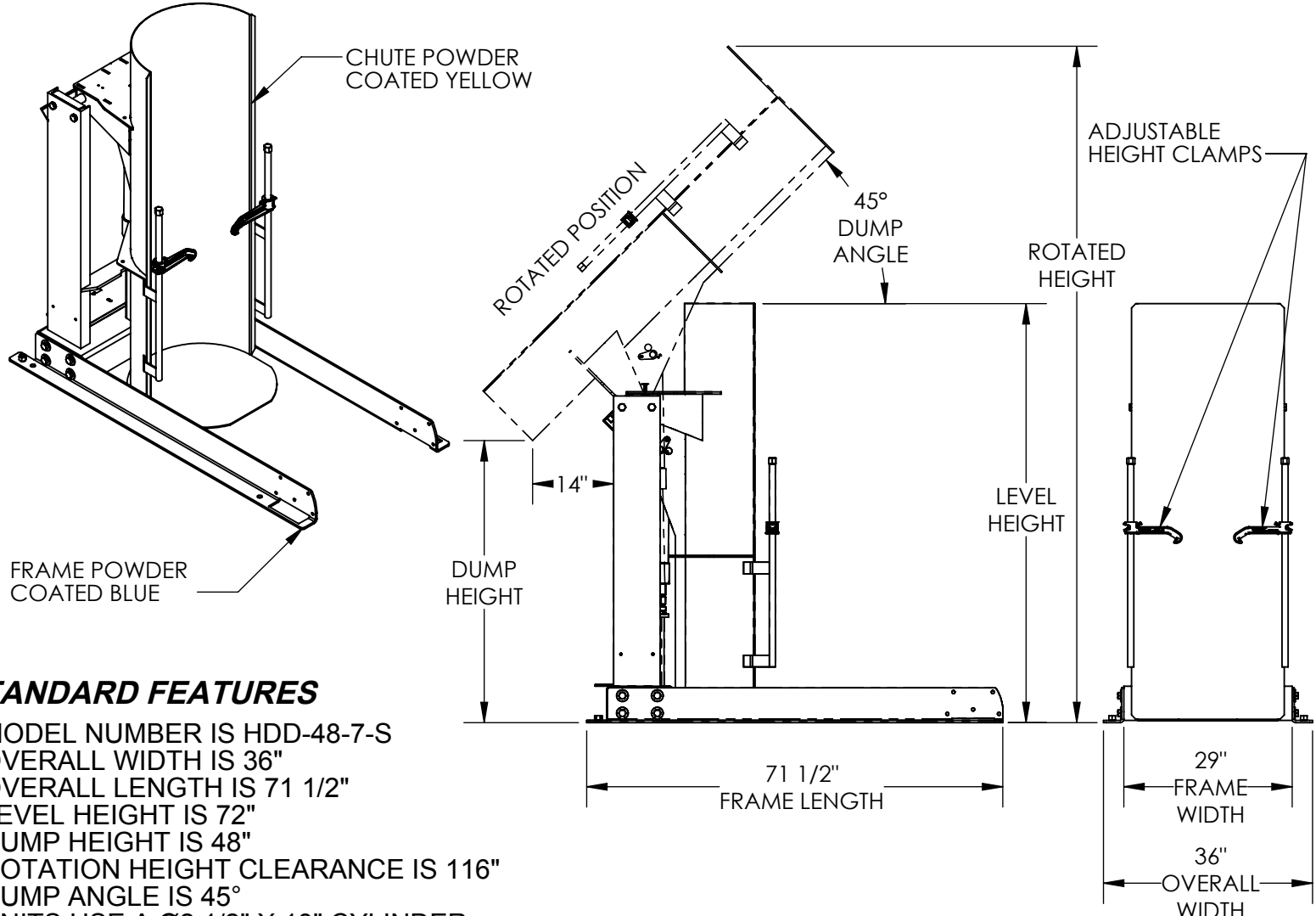

STANDARD FEATURES

- MODEL NUMBER IS HDD-48-7-S
- OVERALL WIDTH IS 36"
- OVERALL LENGTH IS 71 1/2"
- LEVEL HEIGHT IS 72"
- DUMP HEIGHT IS 48"
- ROTATION HEIGHT CLEARANCE IS 116"
- DUMP ANGLE IS 45°
- UNITS USE A Ø2 1/2" X 18" CYLINDER
- MAX CAPACITY IS 750 LBS,
- ALL STEEL CONSTRUCTION
- PENDANT HAND CONTROL WITH 8' CORD AND HOLDER
- TOUGH BAKED IN POWDER COATED FINISH

SPECIAL FEATURES

NONE

DIMENSION TOLERANCE ± 1/4"

FOR INTERNAL USE ONLY PROJECT SIGN OFF	
SALES	
ENG.	
FAB.	
POWER	

3,000 P.S.I. HYDRAULIC COMPONENTS RATING
WARNING: CHECK STATE AND LOCAL CODES !!!
UNIT MUST BE SECURED TO FLOOR BEFORE USE

PLEASE CIRCLE SPECIFICATIONS:

POWER	<input checked="" type="checkbox"/> AC	<input type="checkbox"/> *DC	<input type="checkbox"/> * AIR/OIL	
MOTOR VOLTAGE	<input checked="" type="checkbox"/> 115	<input type="checkbox"/> 208	<input type="checkbox"/> 230	<input type="checkbox"/> 460
DEDICATED CIRCUIT REQUIRED				
MOTOR PHASE	<input checked="" type="checkbox"/> SINGLE	<input type="checkbox"/> THREE		
CONTROL	<input checked="" type="checkbox"/> HAND	<input type="checkbox"/> * FOOT		
~ ALL BATTERY CHARGERS ARE 115V AC ~				
* BATTERY CHRG.	<input type="checkbox"/> REMOTE	<input type="checkbox"/> ON-BOARD		
* CHRG. INDICATOR	<input type="checkbox"/> YES	<input type="checkbox"/> NO		

* AVAILABLE AT ADDITIONAL COST

APPROVAL

I, THE UNDERSIGNED, AGREE THAT THE PRODUCT AS REPRESENTED SATISFIES DESIGN AND DIMENSION REQUIREMENTS. I ALSO ACKNOWLEDGE MY DUTY TO CONFIRM PRODUCT AND INSTALLATION COMPLIANCE WITH ALL APPLICABLE FEDERAL, STATE AND LOCAL REGULATIONS AND STANDARDS.

ANY MODIFIED UNITS ARE NON-RETURNABLE

[] As drawn [] As marked

Signed: _____ Date: _____

Printed Name: _____

LEAD TIME WILL START UPON RECEIPT OF SIGNED APPROVAL DRAWING

DISTRIBUTOR'S NAME:		P.O.#
VESTIL MANUFACTURING		X
DRAWN BY: CRM		W.O.#
DATE: 08/12/2010		X
REFERENCE: X	SCALE: 1:28	SALES: X
QUOTED LEAD TIME: X	QUOTE # X	FILE NAME:
		09-007-123