

HYDRA LIFT CART - HYDRA-HD

APPROX WEIGHT: 228.56 lbs.
DOES NOT INCLUDE WEIGHT OF POWER OR PACKAGING!!!

*** ANY ADDITIONS, DELETIONS, OR OMISSIONS MUST BE CORRECTED ON THIS DRAWING AS THIS DRAWING WILL BE CONSIDERED ALL INCLUSIVE ***

ALL GRAPHICS PROVIDED ARE FOR REFERENCE ONLY. IF CERTAIN DIMENSIONS ARE CRITICAL PLEASE VERIFY THOSE DIMENSIONS WITH YOUR SALESPERSON

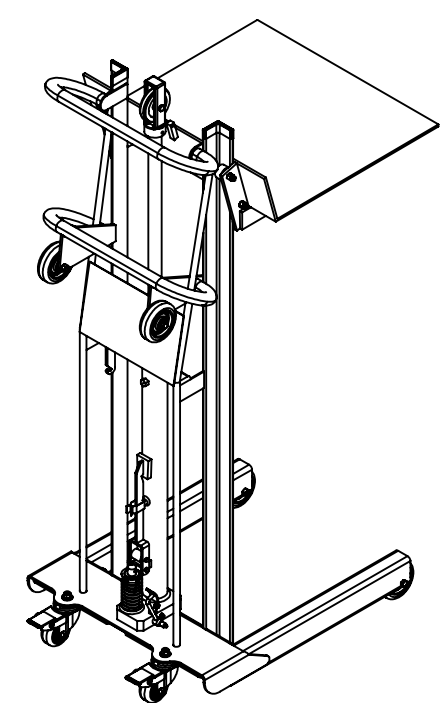
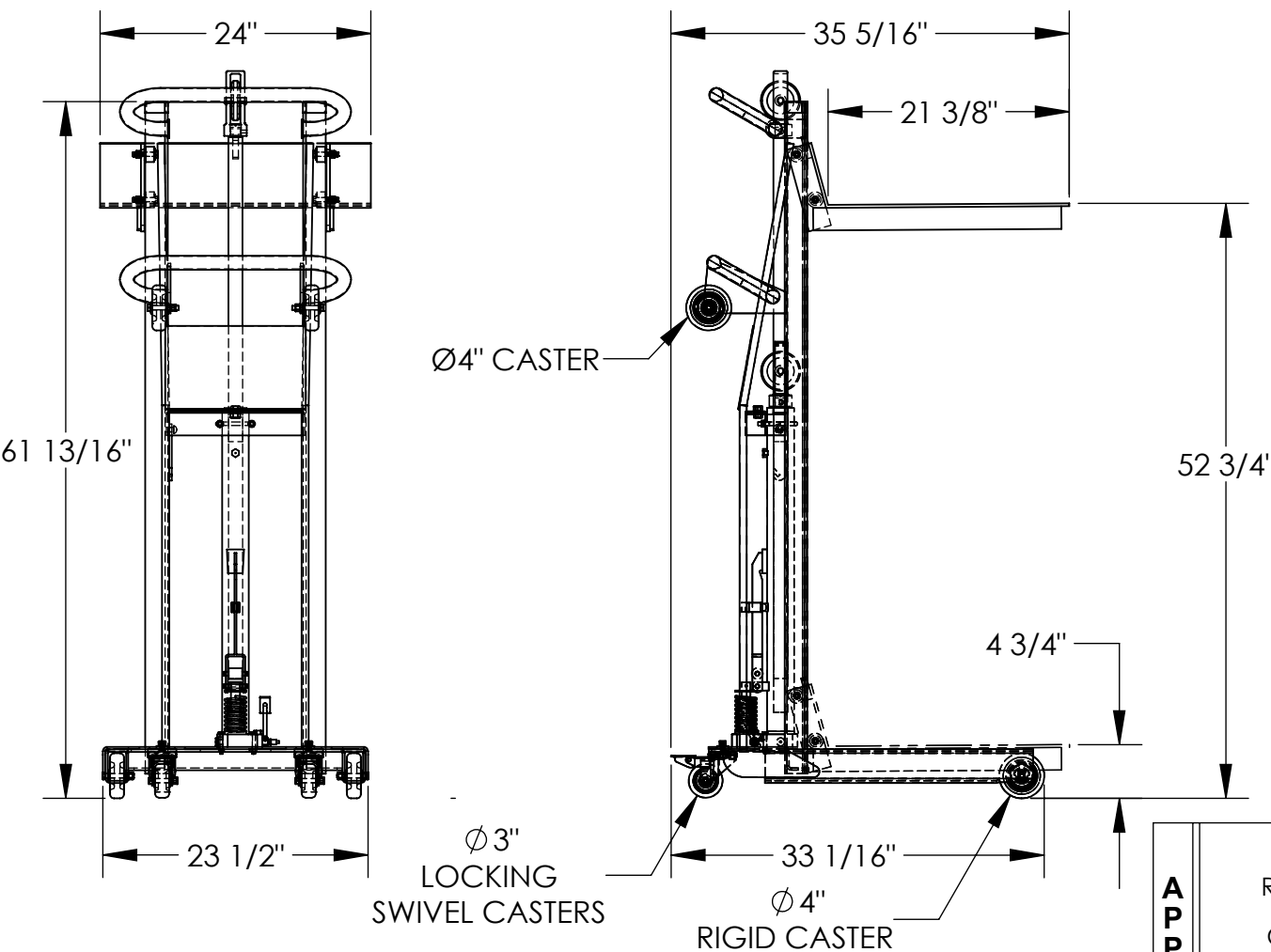

DIMENSION TOLERANCE ± 1/4"

STANDARD FEATURES

- MODEL NUMBER: HYDRA-HD
- CAPACITY: 1,000 LBS
- OVERALL WIDTH: 24"
- OVERALL LENGTH: 35 5/16"
- OVERALL HEIGHT: 61 13/16" (FULLY RAISED)
- PLATFORM SIZE: 24" WIDE x 21 3/8" LONG
- SERVICE RANGE: 4 3/4" TO 52 3/4"
- 3" x 1 1/4" LOCKING SWIVEL CASTERS IN BACK
- 4" x 1 1/4" WHEELS IN FRONT
- FOOT PUMP OPERATION
- TOUGH BAKED IN POWDER COATED BLUE FINISH

SPECIAL FEATURES

NONE

APPROVAL

I, THE UNDERSIGNED, AGREE THAT THE PRODUCT AS REPRESENTED SATISFIES DESIGN AND DIMENSION REQUIREMENTS. I ALSO ACKNOWLEDGE MY DUTY TO CONFIRM PRODUCT AND INSTALLATION COMPLIANCE WITH ALL APPLICABLE FEDERAL, STATE AND LOCAL REGULATIONS AND STANDARDS.

ANY MODIFIED UNITS ARE NON-RETURNABLE

[] As drawn [] As marked

Signed: _____ Date: _____

Printed Name: _____

LEAD TIME WILL START UPON RECEIPT OF SIGNED APPROVAL DRAWING

FOR INTERNAL USE ONLY PROJECT SIGN OFF	
SALES	
ENG.	
FAB.	
POWER	

DISTRIBUTOR'S NAME:		P.O.#
VESTIL MANUFACTURING		X
W.O.#		X
DRAWN BY: DLS	DATE: 1/17/2012	SALES: X
REFERENCE: X	SCALE: 1:16	FILE NAME:
QUOTED LEAD TIME: X	QUOTE # X	33-007-107