

ROTARY AIR/HYDRAULIC SCISSOR TABLE, AHLT-4872-3-43

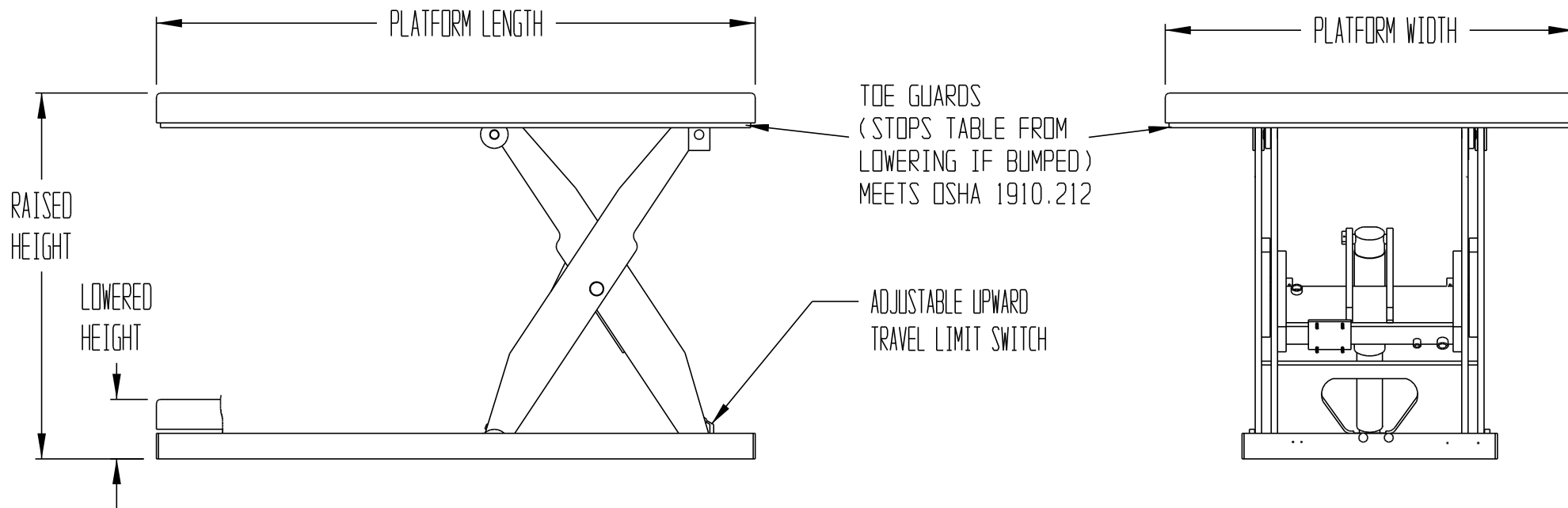

STANDARD FEATURES:

SCISSOR TABLE MODEL NUMBER IS AHLT-4872-3-43
 PLATFORM WIDTH IS 48 INCHES
 PLATFORM LENGTH IS 72 INCHES
 PLATFORM RAISED HEIGHT IS 43 INCHES
 PLATFORM LOWERED HEIGHT IS 7 INCHES
 TABLE CAPACITY (EVENLY DISTRIBUTED LOAD) IS 3,000 LBS.
 CONNECTION: 1/2" NPT AIR LINE
 HINGED MAINTENANCE PROPS, PNEUMATIC UPPER TRAVEL LIMIT SWITCH,
 TOE GUARDS, & INTERNAL BRASS VELOCITY FUSE STANDARD

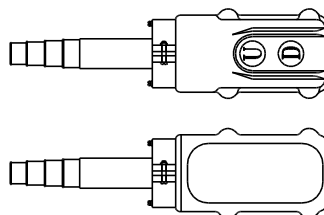

STANDARD 2-BUTTON HAND PENDANT CONTROL

PRODUCTION WILL START UPON RECEIPT OF SIGNED APPROVAL DRAWING

APPROVAL

I, the undersigned, hereby approve this print
 As drawn As marked
 This includes my approval of design & dimensions.
 Signed: _____
 Date: _____

SPECIAL FEATURES:

NONE

**SPECIAL UNITS ARE NON-RETURNABLE
 *AVAILABLE AT ADDITIONAL COSTS

PLEASE CIRCLE SPECIFICATIONS:

POWER	<input type="checkbox"/> AC	<input checked="" type="checkbox"/> DC (12V)	<input type="checkbox"/> AIR/OIL	
MOTOR VOLTAGE	<input type="checkbox"/> 115	<input type="checkbox"/> 208	<input type="checkbox"/> 230	<input type="checkbox"/> 460
DEDICATED CIRCUIT REQUIRED				
MOTOR PHASE	<input type="checkbox"/> SINGLE		<input type="checkbox"/> THREE	
CONTROL	<input checked="" type="checkbox"/> HAND	<input type="checkbox"/> *FOOT		
POWER UNIT LOCATION	<input checked="" type="checkbox"/> INTERNAL	<input type="checkbox"/> *EXTERNAL		

DISTRIBUTOR'S NAME: T & S EQUIPMENT		P.O.#: _
DRAWN BY: SR		DATE: 8-2-04
REFERENCE:		SALES: _
		DRWG./FILE NAME: 24-007-081-102