

ROTARY AIR/HYDRAULIC SCISSOR TABLE, AHLT-4848-3-43

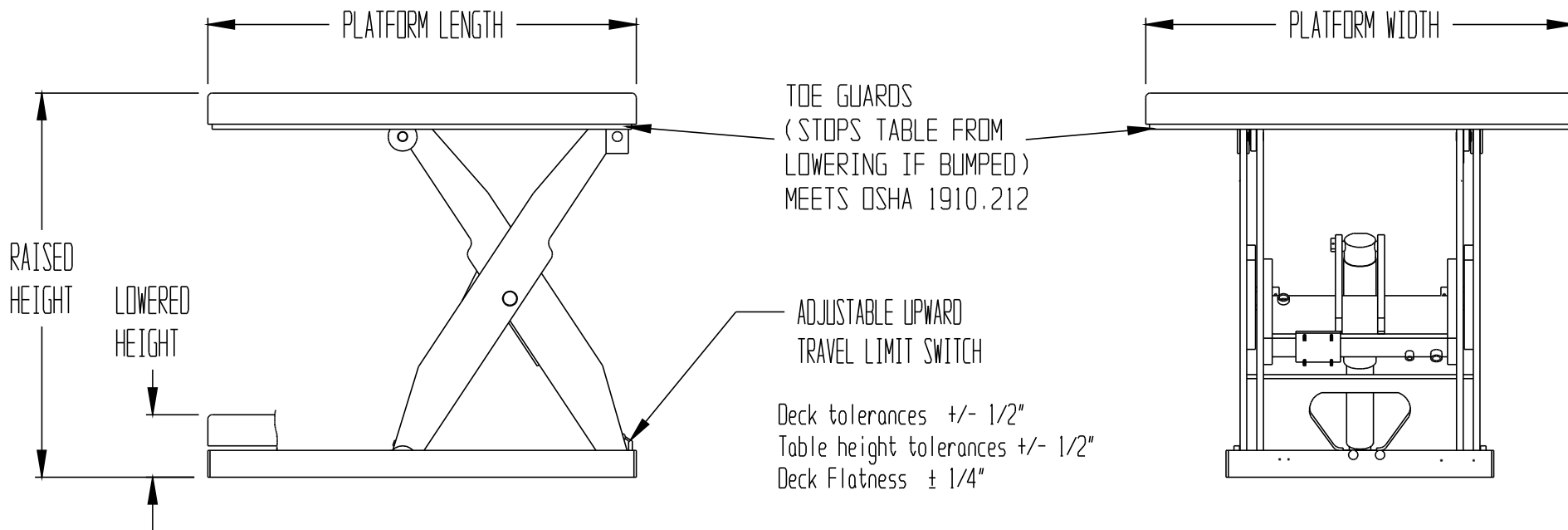

STANDARD FEATURES:

SCISSOR TABLE MODEL NUMBER IS AHLT-4848-3-43
 PLATFORM WIDTH IS 48 INCHES
 PLATFORM LENGTH IS 48 INCHES
 PLATFORM RAISED HEIGHT IS 43 INCHES
 PLATFORM LOWERED HEIGHT IS 7 INCHES
 TABLE CAPACITY (EVENLY DISTRIBUTED LOAD) IS 3,000 LBS.
 CONNECTION: 1/2" NPT AIR LINE
 HINGED MAINTENANCE PROPS, PNEUMATIC UPPER TRAVEL LIMIT SWITCH,
 TOE GUARDS, & INTERNAL BRASS VELOCITY FUSE STANDARD

PLEASE CIRCLE SPECIFICATIONS:

POWER	<input type="checkbox"/> AC	<input type="checkbox"/> DC < 12V	<input checked="" type="checkbox"/> AIR/OIL	
MOTOR VOLTAGE	<input type="checkbox"/> 115	<input type="checkbox"/> 208	<input type="checkbox"/> 230	<input type="checkbox"/> 460
DEDICATED CIRCUIT REQUIRED				
MOTOR PHASE	<input type="checkbox"/> SINGLE	<input type="checkbox"/> THREE		
CONTROL	<input checked="" type="checkbox"/> HAND	<input type="checkbox"/> *FOOT		
POWER UNIT LOCATION	<input checked="" type="checkbox"/> INTERNAL	<input type="checkbox"/> *EXTERNAL		

***ROTARY-##### ROTARY AIR/OIL POWER UNIT,
 AIR REQUIREMENT 80 cfm @ 80 psi
 REQUIRES A FILTER/REGULATOR/LUBRICATOR, FRL
 WARRANTY IS VOID IF NOT USED
 3/4" dia AIR SUPPLY @ 50 ft MAX
 DECIBEL LEVEL 100dB @ 6 ft, 90dB @ 10 ft

**A
P
P
R
O
V
A
L**

I, THE UNDERSIGNED, AGREE THAT THE PRODUCT AS REPRESENTED SATISFIES DESIGN & DIMENSION REQUIREMENTS. I ALSO ACKNOWLEDGE MY DUTY TO CONFIRM PRODUCT & INSTALLATION COMPLIANCE WITH ALL APPLICABLE FEDERAL, STATE AND LOCAL REGULATIONS & STANDARDS.

ALL SPECIAL UNITS ARE NON-RETURNABLE
 () As drawn () As marked

Signed: _____ Date: _____
 LEAD TIME WILL START UPON RECEIPT OF SIGNED APPROVAL DRAWING

SPECIAL FEATURES:

NONE

Any additions, deletions or omissions must be corrected on this drawing, as this drawing will be considered all inclusive.

All graphics provided are for reference only. If certain dimensions are critical please verify those dimensions with your salesperson

DISTRIBUTOR'S NAME: VESTIL MFG		P.O.#: _
DRAWN BY: _____		W.O.#: _
DATE: _	SALES: _	
REFERENCE: _	SCALE: N/A	DRWG./FILE NAME: 24-007-081-101
QUOTED LEADTIME: _	QUOTE #: _	