

# HYDRAULIC BOX DUMPER - HBD-4-36

APPROX WEIGHT: 1636.92 lbs.  
 DOES NOT INCLUDE WEIGHT OF POWER OR PACKAGING!!!

\*\*\* ANY ADDITIONS, DELETIONS, OR OMISSIONS MUST BE CORRECTED ON THIS DRAWING AS THIS DRAWING WILL BE CONSIDERED ALL INCLUSIVE \*\*\*

ALL GRAPHICS PROVIDED ARE FOR REFERENCE ONLY. IF CERTAIN DIMENSIONS ARE CRITICAL PLEASE VERIFY THOSE DIMENSIONS WITH YOUR SALESPERSON

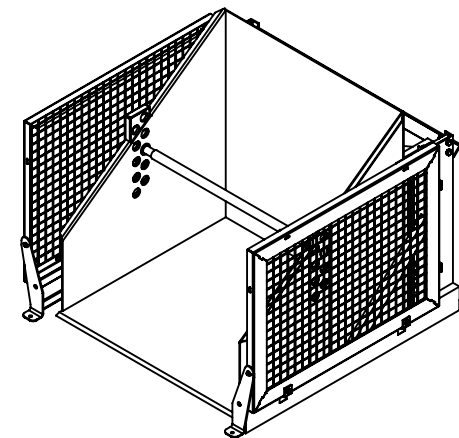
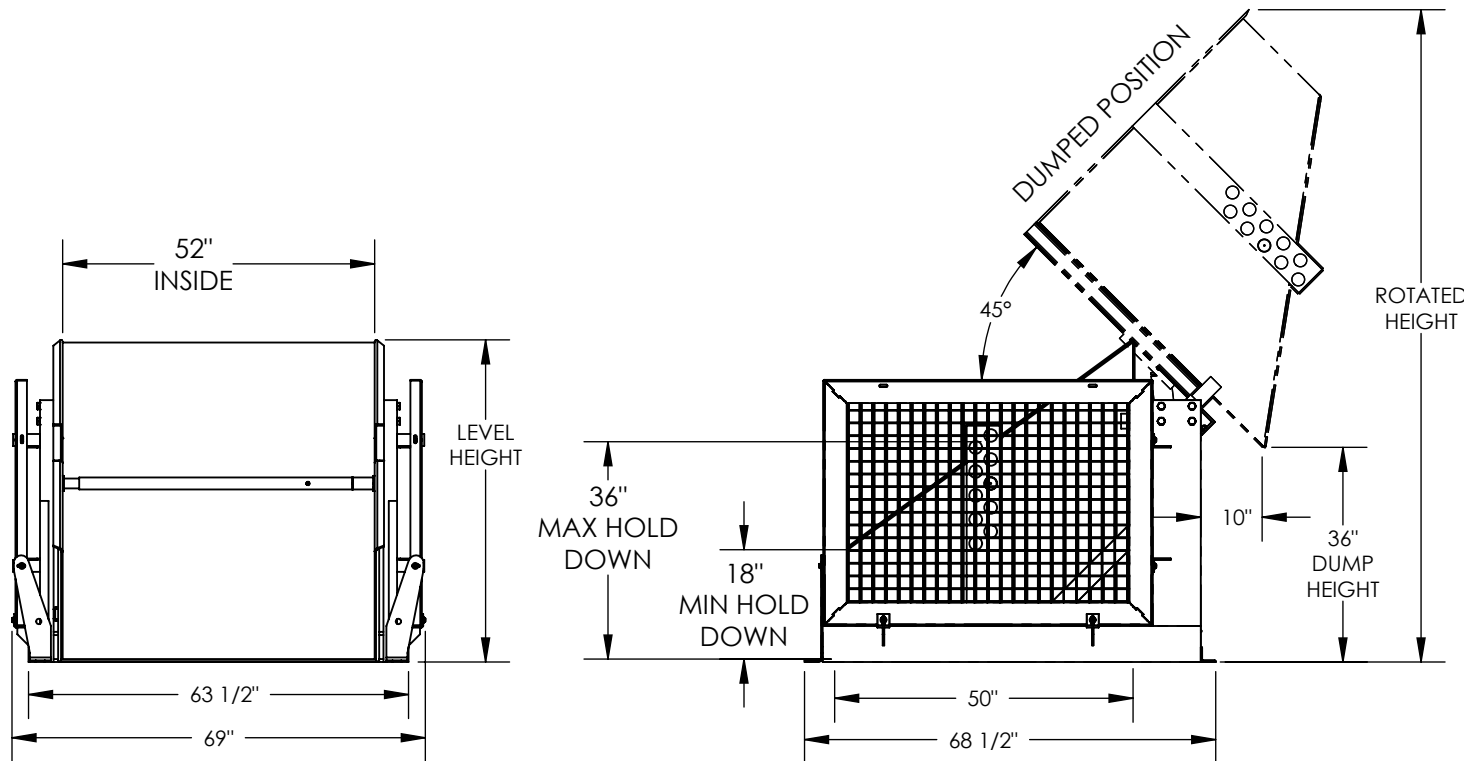

FOR INTERNAL USE ONLY	
PROJECT SIGN OFF	
SALES	
ENG.	
FAB.	
POWER	

## STANDARD FEATURES

- HYDRAULIC BOX DUMPER
- MODEL NUMBER IS HBD-4-36
- CHUTE IS 52" W X 50" L (USABLE)
- DUMPER CAPACITY IS 4000 LBS.
- DUMP HEIGHT IS 36"
- HOLD DOWN WILL ACCEPT BOXES 18" TO 36" HIGH W/ HOLES EVERY 2"
- FRAME WIDTH IS 69"
- FRAME LENGTH IS 68 1/2"
- LEVEL HEIGHT IS 53 1/2"
- ROTATED HEIGHT IS 111"
- DUMP ANGLE IS 45°
- CHROME PLATED CYLINDER WITH EMERGENCY STOP VELOCITY FUSE
- PAINT IS VESTIL ROYAL BLUE
- WARNING: CHECK STATE AND LOCAL CODES!!

NOTE: SINGLE PH. PLUG-IN UNITS WILL HAVE APPROX 120 SEC DUMP / 33 SEC LOWER

### PLEASE CIRCLE SPECIFICATIONS:

POWER	<input checked="" type="checkbox"/> AC	<input type="checkbox"/> * DC	<input type="checkbox"/> * AIR/OIL
MOTOR VOLTAGE	<input type="checkbox"/> 115	<input type="checkbox"/> 208	<input checked="" type="checkbox"/> 230
DEDICATED CIRCUIT REQUIRED			
MOTOR PHASE	<input type="checkbox"/> SINGLE	<input checked="" type="checkbox"/> THREE	
CONTROL	<input checked="" type="checkbox"/> HAND	<input type="checkbox"/> * FOOT	
~ ALL BATTERY CHARGERS ARE 115V AC ~			
* BATTERY CHRG.	<input type="checkbox"/> REMOTE	<input checked="" type="checkbox"/> ON-BOARD	
* CHRG. INDICATOR	<input checked="" type="checkbox"/> YES	<input type="checkbox"/> NO	

\* AVAILABLE AT ADDITIONAL COST

## SPECIAL FEATURES

NONE

DIMENSION TOLERANCE ± 1/4"

APPROVAL

I, THE UNDERSIGNED, AGREE THAT THE PRODUCT AS REPRESENTED SATISFIES DESIGN AND DIMENSION REQUIREMENTS. I ALSO ACKNOWLEDGE MY DUTY TO CONFIRM PRODUCT AND INSTALLATION COMPLIANCE WITH ALL APPLICABLE FEDERAL, STATE AND LOCAL REGULATIONS AND STANDARDS.

**ANY MODIFIED UNITS ARE NON-RETURNABLE**

[ ] As drawn [ ] As marked

Signed: \_\_\_\_\_ Date: \_\_\_\_\_

Printed Name: \_\_\_\_\_

LEAD TIME WILL START UPON RECEIPT OF SIGNED APPROVAL DRAWING

DISTRIBUTOR'S NAME:		P.O.#
VESTIL MANUFACTURING		X
DRAWN BY: CA		DATE: 10/27/2011
REFERENCE: X		SCALE: 1:32
QUOTED LEAD TIME: X		QUOTE # X
SALES: X		FILE NAME: 34-007-036