

HYDRAULIC BOX DUMPER- HBD-2-60

APPROX WEIGHT: 1933.86 lbs.
DOES NOT INCLUDE WEIGHT OF POWER OR PACKAGING!!!

*** ANY ADDITIONS, DELETIONS, OR OMISSIONS MUST BE CORRECTED ON THIS DRAWING AS THIS DRAWING WILL BE CONSIDERED ALL INCLUSIVE ***
ALL GRAPHICS PROVIDED ARE FOR REFERENCE ONLY. IF CERTAIN DIMENSIONS ARE CRITICAL PLEASE VERIFY THOSE DIMENSIONS WITH YOUR SALESPERSON

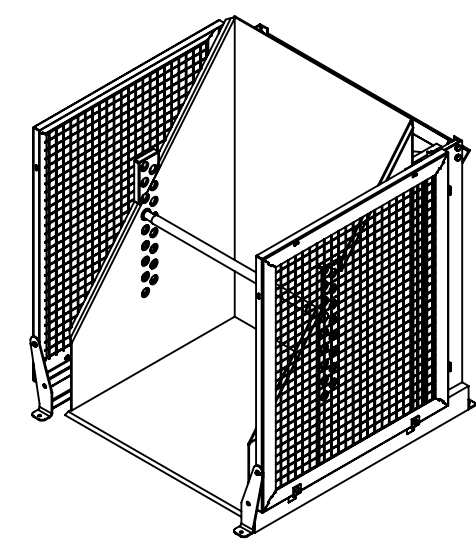
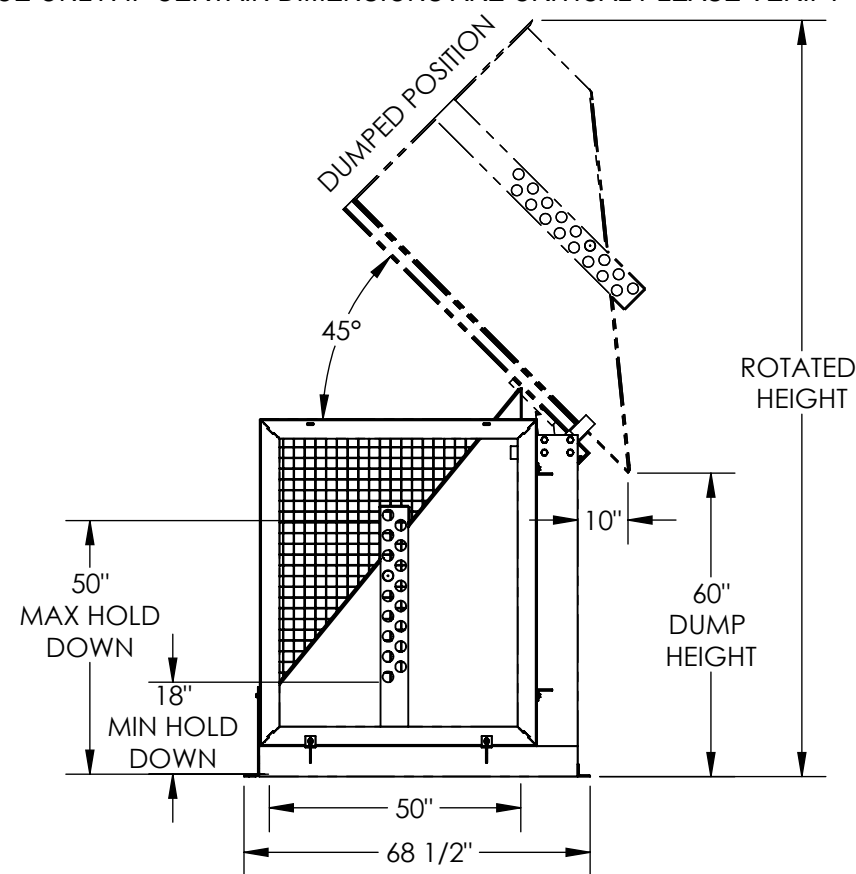
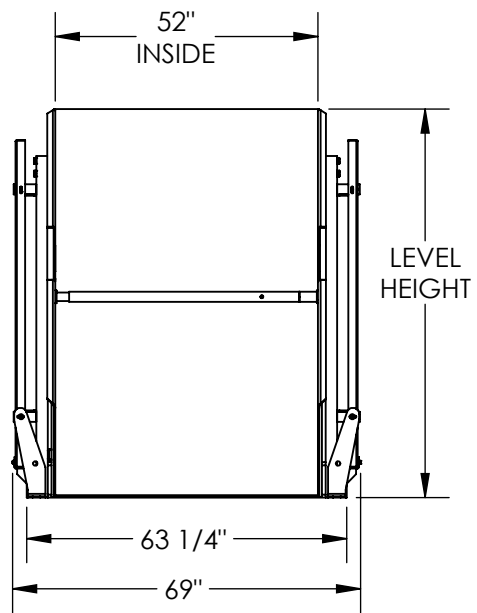

FOR INTERNAL USE ONLY PROJECT SIGN OFF	
SALES	
ENG.	
FAB.	
POWER	

DIMENSION TOLERANCE ± 1/4"

STANDARD FEATURES

HYDRAULIC BOX DUMPER
MODEL NUMBER IS HBD-2-60
CHUTE IS 52" W X 50" L (USABLE)
DUMPER CAPACITY IS 2000 LBS.
DUMP HEIGHT IS 60"
HOLD DOWN WILL ACCEPT BOXES
18" TO 50" HIGH W/ HOLES EVERY 2"
FRAME WIDTH IS 69"
FRAME LENGTH IS 68 1/2"
LEVEL HEIGHT IS 77"
ROTATED HEIGHT IS 149 1/2"
DUMP ANGLE IS 45°
CHROME PLATED CYLINDER WITH
EMERGENCY STOP VELOCITY FUSE
PAINT IS VESTIL ROYAL BLUE
WARNING: CHECK STATE AND LOCAL CODES!!

PLEASE CIRCLE SPECIFICATIONS:

POWER	<input checked="" type="checkbox"/> AC	<input type="checkbox"/> * DC	<input type="checkbox"/> * AIR/OIL
MOTOR VOLTAGE	<input type="checkbox"/> 115	<input type="checkbox"/> 208	<input checked="" type="checkbox"/> 230
DEDICATED CIRCUIT REQUIRED			
MOTOR PHASE	<input type="checkbox"/> SINGLE	<input checked="" type="checkbox"/> THREE	
CONTROL	<input checked="" type="checkbox"/> HAND	<input type="checkbox"/> * FOOT	
~ ALL BATTERY CHARGERS ARE 115V AC ~			
* BATTERY CHRG.	<input type="checkbox"/> REMOTE	<input type="checkbox"/> ON-BOARD	
* CHRG. INDICATOR	<input type="checkbox"/> YES	<input type="checkbox"/> NO	

* AVAILABLE AT ADDITIONAL COST

SPECIAL FEATURES NONE

APPROVAL

I, THE UNDERSIGNED, AGREE THAT THE PRODUCT AS REPRESENTED SATISFIES DESIGN AND DIMENSION REQUIREMENTS. I ALSO ACKNOWLEDGE MY DUTY TO CONFIRM PRODUCT AND INSTALLATION COMPLIANCE WITH ALL APPLICABLE FEDERAL, STATE AND LOCAL REGULATIONS AND STANDARDS.
ANY MODIFIED UNITS ARE NON-RETURNABLE
[] As drawn [] As marked

Signed: _____ Date: _____
Printed Name: _____
LEAD TIME WILL START UPON RECEIPT OF SIGNED APPROVAL DRAWING

DISTRIBUTOR'S NAME: _____ P.O.# X
VESTIL MANUFACTURING W.O.# X
DRAWN BY: CA DATE: 06/23/2011 SALES: X
REFERENCE: X SCALE: 1:38 FILE NAME:
QUOTED LEAD TIME: X QUOTE # X 34-007-006