

HYDRAULIC BOX DUMPERS - HBD-2-36

APPROX WEIGHT: 1614.70 lbs.
 DOES NOT INCLUDE WEIGHT OF POWER OR PACKAGING!!!

*** ANY ADDITIONS, DELETIONS, OR OMISSIONS MUST BE CORRECTED ON THIS DRAWING AS THIS DRAWING WILL BE CONSIDERED ALL INCLUSIVE ***

ALL GRAPHICS PROVIDED ARE FOR REFERENCE ONLY. IF CERTAIN DIMENSIONS ARE CRITICAL PLEASE VERIFY THOSE DIMENSIONS WITH YOUR SALESPERSON

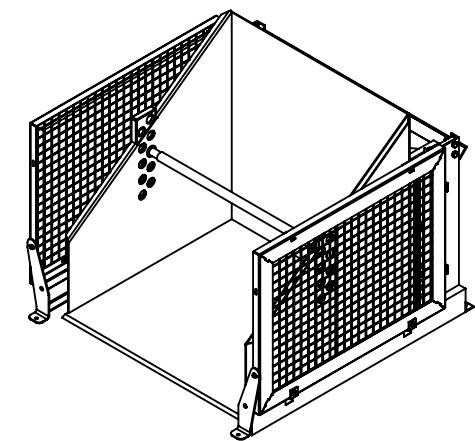
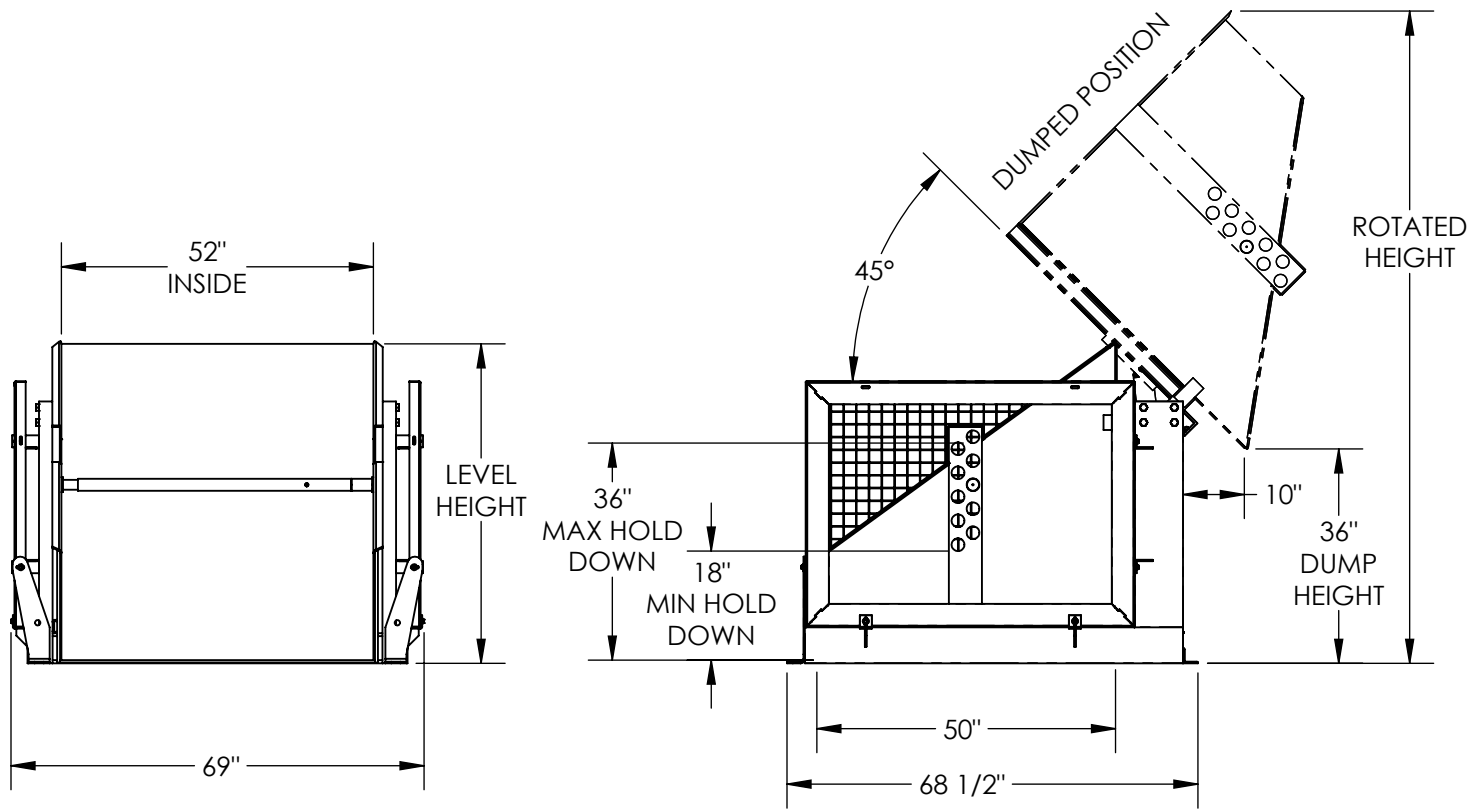

FOR INTERNAL USE ONLY PROJECT SIGN OFF	
SALES	
ENG.	
FAB.	
POWER	

STANDARD FEATURES

- HYDRAULIC BOX DUMPER
- MODEL NUMBER IS HBD-2-36
- CHUTE IS 52" W X 50"L (USABLE)
- DUMPER CAPACITY IS 2000 LBS.
- DUMP HEIGHT IS 36"
- HOLD DOWN WILL ACCEPT BOXES 18" TO 36" HIGH W/ HOLES EVERY 2"
- FRAME WIDTH IS 69"
- FRAME LENGTH IS 68 1/2"
- LEVEL HEIGHT IS 53 1/2"
- ROTATED HEIGHT IS 111"
- DUMP ANGLE IS 45°
- CHROME PLATED CYLINDER WITH EMERGENCY STOP VELOCITY FUSE
- PAINT IS VESTIL ROYAL BLUE
- WARNING: CHECK STATE AND LOCAL CODES!!

NOTE: SINGLE PH. PLUG-IN UNITS WILL HAVE APPROX 120 SEC DUMP / 33 SEC LOWER

PLEASE CIRCLE SPECIFICATIONS:

POWER	<input checked="" type="checkbox"/> AC	<input type="checkbox"/> * DC	<input type="checkbox"/> * AIR/OIL
MOTOR VOLTAGE	<input type="checkbox"/> 115	<input type="checkbox"/> 208	<input checked="" type="checkbox"/> 230
DEDICATED CIRCUIT REQUIRED			
MOTOR PHASE	<input type="checkbox"/> SINGLE	<input checked="" type="checkbox"/> THREE	
CONTROL	<input checked="" type="checkbox"/> HAND	<input type="checkbox"/> * FOOT	
~ ALL BATTERY CHARGERS ARE 115V AC ~			
* BATTERY CHRG.	<input type="checkbox"/> REMOTE	<input checked="" type="checkbox"/> ON-BOARD	
* CHRG. INDICATOR	<input checked="" type="checkbox"/> YES	<input type="checkbox"/> NO	

* AVAILABLE AT ADDITIONAL COST

SPECIAL FEATURES

NONE

DIMENSION TOLERANCE ± 1/4"

APPROVAL

I, THE UNDERSIGNED, AGREE THAT THE PRODUCT AS REPRESENTED SATISFIES DESIGN AND DIMENSION REQUIREMENTS. I ALSO ACKNOWLEDGE MY DUTY TO CONFIRM PRODUCT AND INSTALLATION COMPLIANCE WITH ALL APPLICABLE FEDERAL, STATE AND LOCAL REGULATIONS AND STANDARDS.

ANY MODIFIED UNITS ARE NON-RETURNABLE

[] As drawn [] As marked

Signed: _____ Date: _____

Printed Name: _____

LEAD TIME WILL START UPON RECEIPT OF SIGNED APPROVAL DRAWING

DISTRIBUTOR'S NAME:		P.O.#
VESTIL MANUFACTURING		X
DRAWN BY: CA		W.O.#
DATE: 09/22/2011		X
REFERENCE: X	SCALE: 1:32	SALES: X
QUOTED LEAD TIME: X	QUOTE #	FILE NAME:
	X	34-007-004