

# SELF-ELEVATING SPRING TABLE - ETS-1120-24

APPROX WEIGHT: 272.72 lbs.  
 DOES NOT INCLUDE WEIGHT OF POWER OR PACKAGING!!!

\*\*\* ANY ADDITIONS, DELETIONS, OR OMISSIONS MUST BE CORRECTED ON THIS DRAWING AS THIS DRAWING WILL BE CONSIDERED ALL INCLUSIVE \*\*\*  
 ALL GRAPHICS PROVIDED ARE FOR REFERENCE ONLY. IF CERTAIN DIMENSIONS ARE CRITICAL PLEASE VERIFY THOSE DIMENSIONS WITH YOUR SALESPERSON

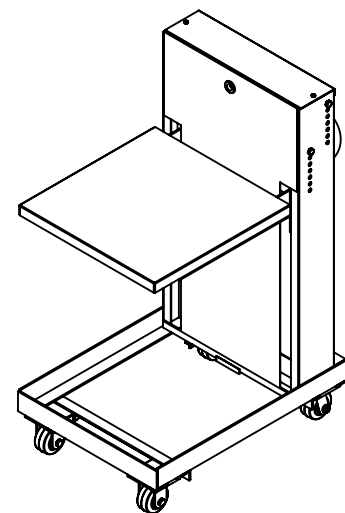
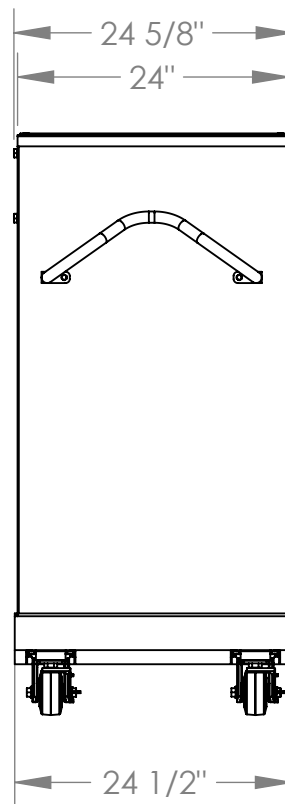
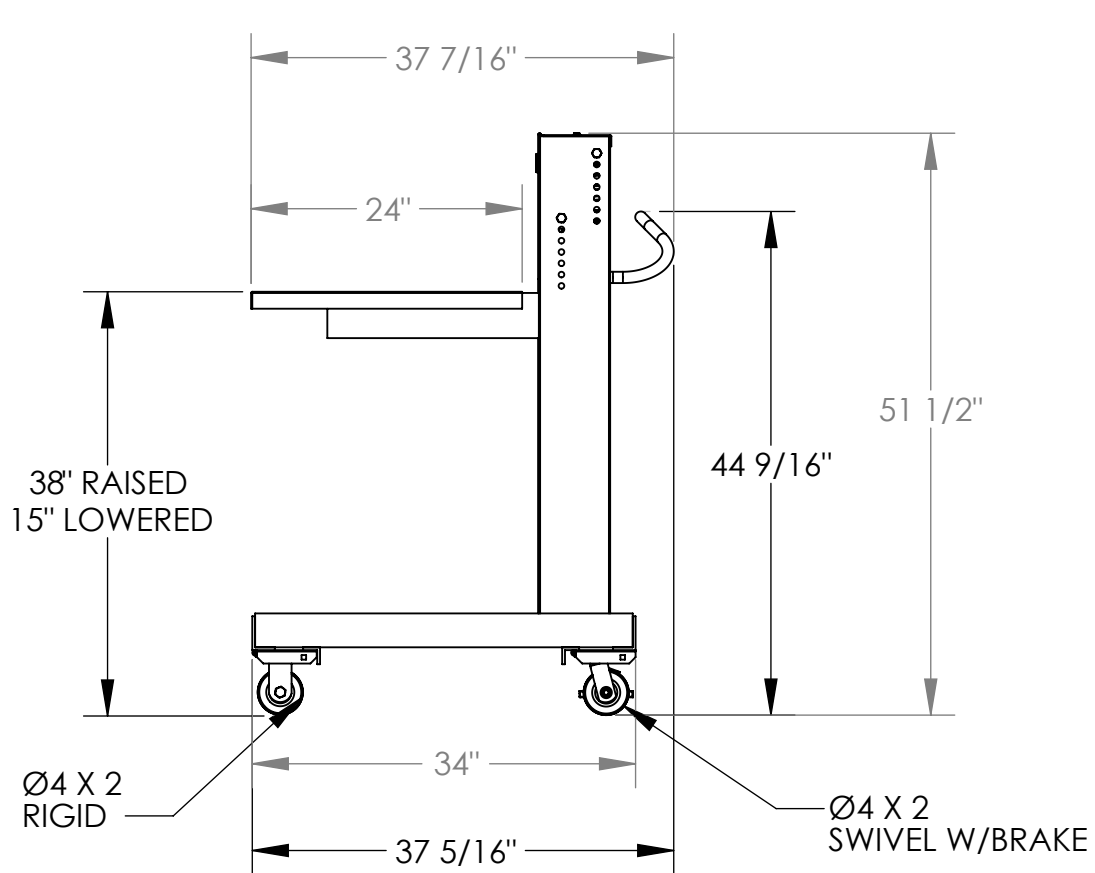

3D VIEW SHOWN FOR REFERENCE ONLY

DIMENSION TOLERANCE ± 1/4"

## STANDARD FEATURES

- MODEL NUMBER IS ETS-1120-24
- CAPACITY: 1120 LBS.
- OVERALL WIDTH IS 24 5/8"
- USABLE PLATFORM WIDTH IS 24"
- OVERALL LENGTH IS 37 7/16"
- USABLE PLATFORM LENGTH IS 24"
- OVERALL HEIGHT IS 51 1/2"
- PLATFORM RAISED HEIGHT: 38"
- PLATFORM LOWERED HEIGHT: 15"
- NO. OF SPRINGS: 5
- SPRING RATE IS 36 LBS PER INCH
- CASTERS: (2) Ø4 X 2 MOLD ON RUBBER SWIVEL W/BRAKE
- (2) Ø4 X 2 MOLD ON RUBBER RIGID

## SPECIAL FEATURES

NONE

APPROVAL

I, THE UNDERSIGNED, AGREE THAT THE PRODUCT AS REPRESENTED SATISFIES DESIGN AND DIMENSION REQUIREMENTS. I ALSO ACKNOWLEDGE MY DUTY TO CONFIRM PRODUCT AND INSTALLATION COMPLIANCE WITH ALL APPLICABLE FEDERAL, STATE AND LOCAL REGULATIONS AND STANDARDS.

**ANY MODIFIED UNITS ARE NON-RETURNABLE**

[ ] As drawn [ ] As marked

Signed: \_\_\_\_\_ Date: \_\_\_\_\_

Printed Name: \_\_\_\_\_

LEAD TIME WILL START UPON RECEIPT OF SIGNED APPROVAL DRAWING

FOR INTERNAL USE ONLY PROJECT SIGN OFF	
SALES	
ENG.	
FAB.	
POWER	

DISTRIBUTOR'S NAME: <b>VESTIL MANUFACTURING</b>		P.O.# X
DRAWN BY: ND		W.O.# X
DATE: 12/19/05	SALES: X	FILE NAME: 21-007-035
REFERENCE: X	SCALE: 1:17	
QUOTED LEAD TIME: X	QUOTE # X	