

# UNIVERSAL MANUAL TRASH CAN DUMPER - TCD-U-48-AC

APPROX WEIGHT: 709.55 lbs. DOES NOT INCLUDE WEIGHT OF POWER OR PACKAGING!!!

\*\*\* ANY ADDITIONS, DELETIONS, OR OMISSIONS MUST BE CORRECTED ON THIS DRAWING AS THIS DRAWING WILL BE CONSIDERED ALL INCLUSIVE \*\*\*  
 ALL GRAPHICS PROVIDED ARE FOR REFERENCE ONLY. IF CERTAIN DIMENSIONS ARE CRITICAL PLEASE VERIFY THOSE DIMENSIONS WITH YOUR SALESPERSON

## STANDARD FEATURES

MODEL NUMBER: TCD-U-48-AC  
 USABLE CHUTE WIDTH: 34 3/4"  
 USAGE CHUTE LENGTH: 35 7/8"  
 USABLE CHUTE HEIGHT: 64"

OVERALL LENGTH: 75 5/8"  
 OVERALL WIDTH: 46 1/16"  
 OVERALL HEIGHT: 64 3/4"

OVERALL ROTATED HEIGHT: 119 3/8"  
 MAXIMUM ROTATED ANGLE: 45°  
 DUMP HEIGHT: 48 9/16"

WORKS WITH TRASH CANS OF  
 17 1/2" TO 34 3/4" WIDTH  
 20 1/2" TO 35 7/8" LENGTH  
 27" TO 50" HEIGHT

UNIFORM CAPACITY IS 400 LBS

CASTERS:  
 FRONT: 8" X 2" GFN SWIVEL  
 REAR: 8" X 2" GFN RIGID

TWO ADJUSTABLE FLOOR LOCKS

POWER UNIT: 115 V AC SINGLE PHASE  
 CONTROL: HAND

## SPECIAL FEATURES

NONE

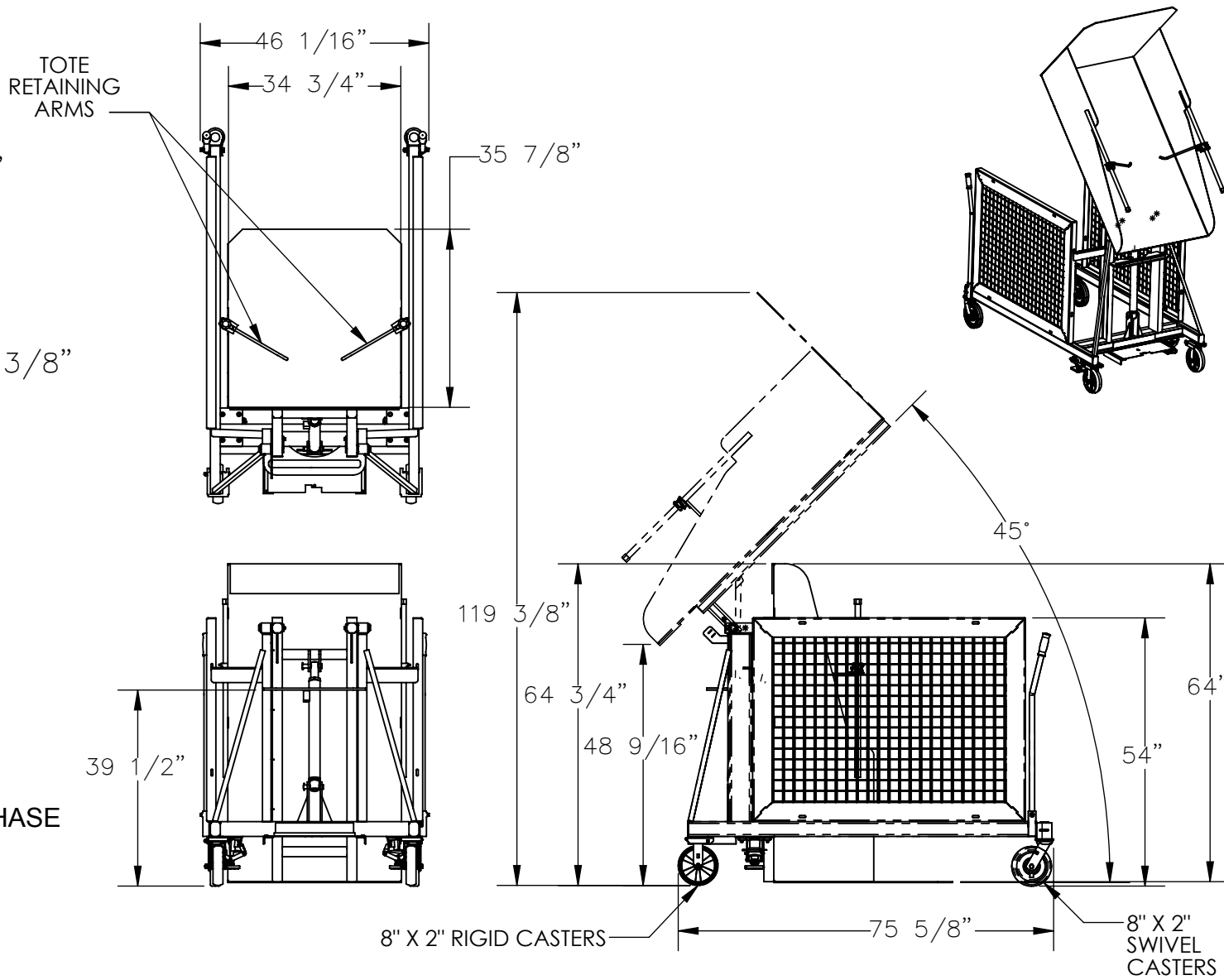

APPROVAL

I, THE UNDERSIGNED, AGREE THAT THE PRODUCT AS REPRESENTED SATISFIES DESIGN AND DIMENSION REQUIREMENTS. I ALSO ACKNOWLEDGE MY DUTY TO CONFIRM PRODUCT AND INSTALLATION COMPLIANCE WITH ALL APPLICABLE FEDERAL, STATE AND LOCAL REGULATIONS AND STANDARDS.

**ANY MODIFIED UNITS ARE NON-RETURNABLE**  
 As drawn     As marked

Signed: \_\_\_\_\_ Date: \_\_\_\_\_

Printed Name: \_\_\_\_\_

LEAD TIME WILL START UPON RECEIPT OF SIGNED APPROVAL DRAWING

FOR INTERNAL USE ONLY PROJECT SIGN OFF	
SALES	
ENG.	
FAB.	
POWER	

DISTRIBUTOR'S NAME: <b>VESTIL MANUFACTURING</b>	
DRAWN BY: SJA	DATE: 7/23/2016
REFERENCE: X	SCALE: 1:32
QUOTED LEAD TIME: X	QUOTE # X

P.O.# X
W.O.# X
SALES: X
FILE NAME: 34-007-023-001