

# FORK LIFT TIE DOWN CLAMPS - FTDC-6-4400

APPROX WEIGHT: 33.70 lbs.  
 DOES NOT INCLUDE WEIGHT OF POWER OR PACKAGING!!!

\*\*\* ANY ADDITIONS, DELETIONS, OR OMISSIONS MUST BE CORRECTED ON THIS DRAWING AS THIS DRAWING WILL BE CONSIDERED ALL INCLUSIVE \*\*\*

ALL GRAPHICS PROVIDED ARE FOR REFERENCE ONLY. IF CERTAIN DIMENSIONS ARE CRITICAL PLEASE VERIFY THOSE DIMENSIONS WITH YOUR SALESPERSON

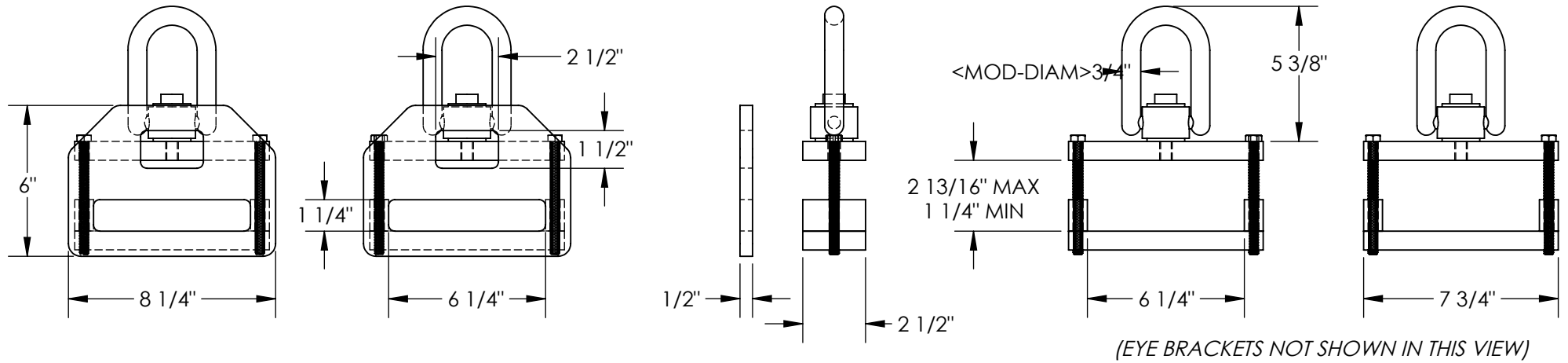

## PRODUCT DETAILS

MODEL NUMBER: FTDC-6-4400  
 UNIFORM CAPACITY: 4,400 LBS.  
 (2200 LBS. PER CLAMP/BRAKET SET)  
 CLAMPS TO FIT FORKS 6"W x 2 3/4"H  
 STEEL CONSTRUCTION  
 TOUGH BAKED IN POWDERCOATED YELLOW FINISH

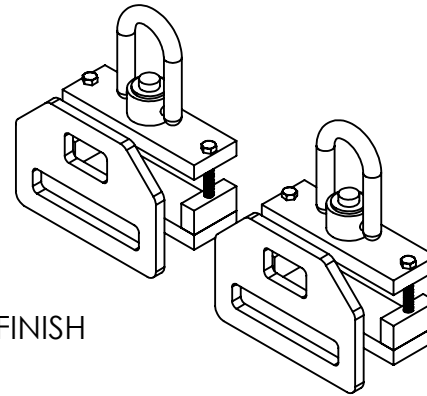

## EYE BRACKET FEATURES

OVERALL EYE BRACKET WIDTH: 8 1/4"  
 OVERALL EYE BRACKET HEIGHT: 6"  
 EYE BRACKET FORK OPENING: 6 1/4"W x 1 1/4"H  
 EYE BRACKET LIFT OPENING: 2 1/2"W x 1 1/2"H  
 EYE BRACKET THICKNESS: 1/2"

## SCREW CLAMP W/SWIVEL EYE FEATURES:

OVERALL SCREW CLAMP WIDTH: 7 3/4"  
 OVERALL SCREW CLAMP DEPTH: 2 1/2"  
 MAX. USABLE HEIGHT: 2 13/16"  
 MIN. USABLE HEIGHT: 1 1/4"  
 EACH CLAMP INCLUDES SWIVEL EYE

DIMENSION TOLERANCE ± 1/4"

<b>APPROVAL</b>	I, THE UNDERSIGNED, AGREE THAT THE PRODUCT AS REPRESENTED SATISFIES DESIGN AND DIMENSION REQUIREMENTS. I ALSO ACKNOWLEDGE MY DUTY TO CONFIRM PRODUCT AND INSTALLATION COMPLIANCE WITH ALL APPLICABLE FEDERAL, STATE AND LOCAL REGULATIONS AND STANDARDS.	
	<b>ANY MODIFIED UNITS ARE NON-RETURNABLE</b>	
	[ ] As drawn      [ ] As marked	
	Signed: _____ Date: _____	
Printed Name: _____		
<b>LEAD TIME WILL START UPON RECEIPT OF SIGNED APPROVAL DRAWING</b>		

FOR INTERNAL USE ONLY PROJECT SIGN OFF	
SALES	
ENG.	
FAB.	
POWER	

DISTRIBUTOR'S NAME:		P.O.#
VESTIL MANUFACTURING		X
DRAWN BY: CJC	DATE: 5/30/19	W.O.#
REFERENCE: X	SCALE: 1:6	X
QUOTED LEAD TIME: X	QUOTE #	FILE NAME:
	X	47-007-049