

# GROUND LIFT SCISSOR TABLE - EHLTG-4484-3-54

APPROX WEIGHT: 2555.87 lbs.  
 DOES NOT INCLUDE WEIGHT OF POWER OR PACKAGING!!!

\*\*\* ANY ADDITIONS, DELETIONS, OR OMISSIONS MUST BE CORRECTED ON THIS DRAWING AS THIS DRAWING WILL BE CONSIDERED ALL INCLUSIVE \*\*\*

ALL GRAPHICS PROVIDED ARE FOR REFERENCE ONLY. IF CERTAIN DIMENSIONS ARE CRITICAL PLEASE VERIFY THOSE DIMENSIONS WITH YOUR SALESPERSON

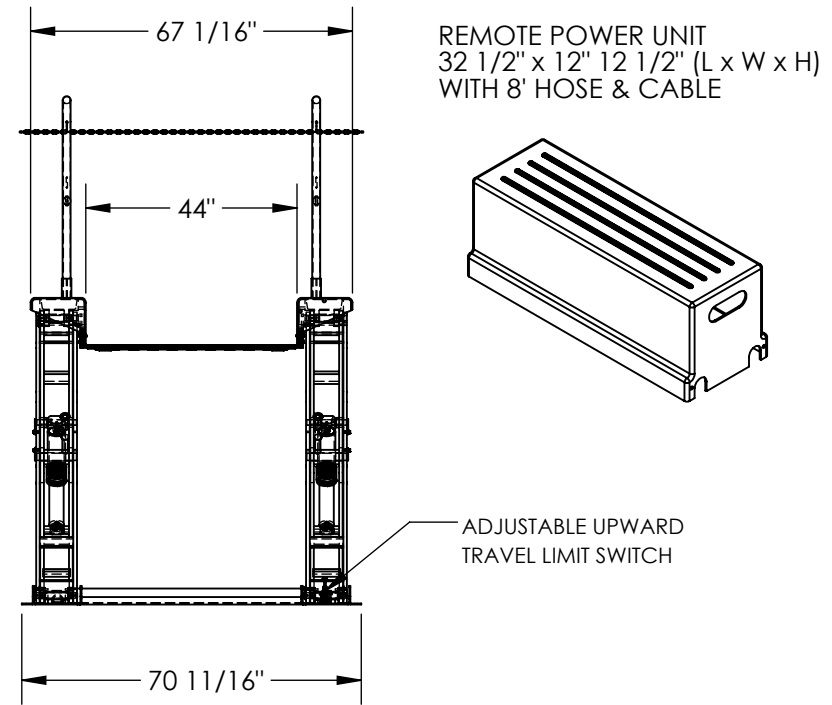
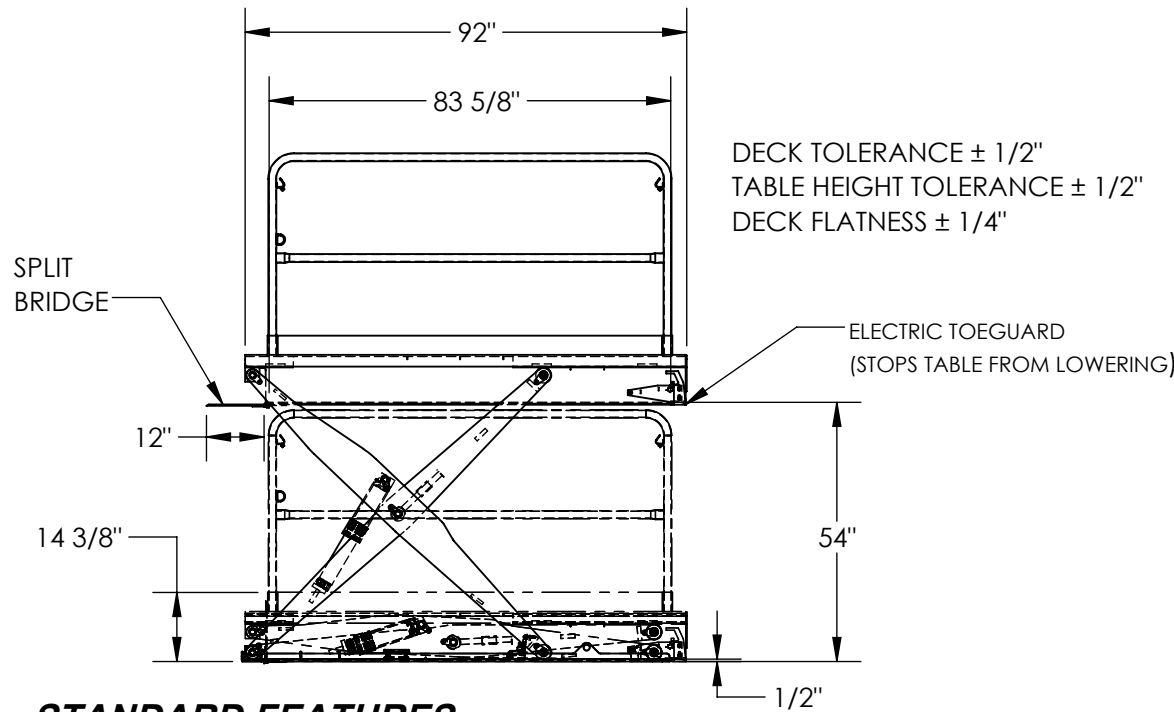

## STANDARD FEATURES

- MODEL NUMBER IS EHLTG-4484-3-54
- OVERALL WIDTH IS 70 11/16"
- USABLE WIDTH IS 44"
- OVERALL LENGTH IS 92"
- USABLE LENGTH IS 83 5/8"
- RAISED HEIGHT IS 54"
- LOWERED HEIGHT IS 1/2"
- 12" WIDE BY 44" LONG SLIT BRIDGE
- TABLE CAPACITY (EVENLY DISTRIBUTED) IS 3,000 LBS.
- EXTERNAL POWER UNIT
- NON-REMOVABLE TOE BOARDS
- SAFETY MAINTENANCE PROPS
- DISPLACEMENT STYLE CYLINDERS
- INSTALLED ROD DOWN
- EMERGENCY SAFETY STOP HYDRAULIC FUSES IN ALL CYLINDERS
- UNITS HAVE 2' TEST LEAD AND PIG TAIL
- CONTROL IS FOOT SWITCH, 2 PEDAL, NEMA 1 WITH MINIMUM USABLE 8' STRAIGHT CORD
- DURABLE LIQUID PAINT BLUE FINISH WITH TOUGH BAKED IN POWDER COATED YELLOW FINISH REMOVABLE HAND RAILS

## SPECIAL FEATURES

NONE

## PLEASE CIRCLE SPECIFICATIONS:

POWER	AC	<del>DC (12V)</del>	<del>AIR/OIL</del>
MOTOR VOLTAGE	<del>115</del>	<del>208</del>	<del>230</del> 460
DEDICATED CIRCUIT REQUIRED 60Hz			
MOTOR PHASE	<del>SINGLE</del>	THREE	
CONTROL	<del>HAND</del>	FOOT	

DIMENSION TOLERANCE ± 1/4"

**APPROVAL**

I, THE UNDERSIGNED, AGREE THAT THE PRODUCT AS REPRESENTED SATISFIES DESIGN AND DIMENSION REQUIREMENTS. I ALSO ACKNOWLEDGE MY DUTY TO CONFIRM PRODUCT AND INSTALLATION COMPLIANCE WITH ALL APPLICABLE FEDERAL, STATE AND LOCAL REGULATIONS AND STANDARDS.

**ANY MODIFIED UNITS ARE NON-RETURNABLE**

[ ] As drawn [ ] As marked

Signed: \_\_\_\_\_ Date: \_\_\_\_\_

Printed Name: \_\_\_\_\_

LEAD TIME WILL START UPON RECEIPT OF SIGNED APPROVAL DRAWING

FOR INTERNAL USE ONLY  
 PROJECT SIGN OFF

SALES	
ENG.	
FAB.	
POWER	

DISTRIBUTOR'S NAME: VESTIL MANUFACTURING

P.O.# X

W.O.# X

SALES: X

FILE NAME: 04-007-113

DRAWN BY: JWW DATE: 8/15/19

REFERENCE: X SCALE: 1:40

QUOTED LEAD TIME: X QUOTE # X