

HYDRAULIC TRASH COMPACTOR - MTC-PNU-55

APPROX WEIGHT: 501.63 lbs.
DOES NOT INCLUDE WEIGHT OF POWER OR PACKAGING!!!

*** ANY ADDITIONS, DELETIONS, OR OMISSIONS MUST BE CORRECTED ON THIS DRAWING AS THIS DRAWING WILL BE CONSIDERED ALL INCLUSIVE ***

ALL GRAPHICS PROVIDED ARE FOR REFERENCE ONLY. IF CERTAIN DIMENSIONS ARE CRITICAL PLEASE VERIFY THOSE DIMENSIONS WITH YOUR SALESPERSON

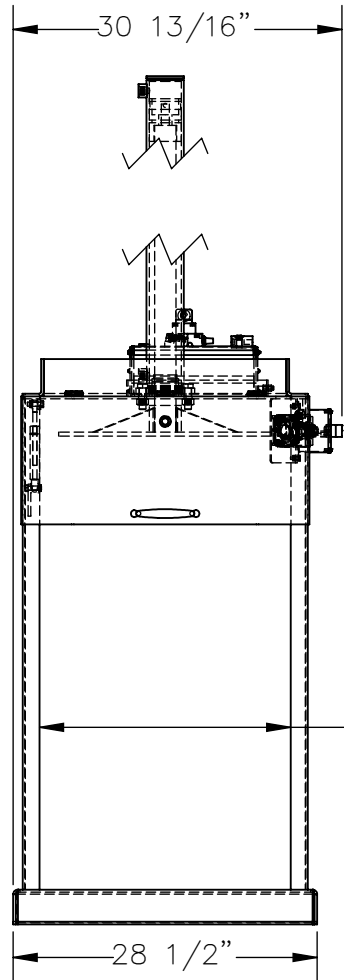

STANDARD FEATURES

- MODEL NUMBER IS MTC-PNU-55
- OVERALL WIDTH: 30 13/16"
- USABLE WIDTH: 23 9/16"
- OVERALL LENGTH: 39 1/2"
- OVERALL HEIGHT: 92 1/8"
- FORK POCKET OPENING: 2 5/8" X 7 5/8"
- USE WITH STEEL 55 GAL DRUMS
- CYLINDER FORCE: 21,210 PSI
- COMPACTION FORCE: 68 PSI
- OPERATIONAL AIR FLOW: 15 CFM
- OPERATIONAL AIR PRESSURE: 90 PSI
- MANUAL DIRECTIONAL CONTROL VALVE
- DURABLE LIQUID PAINT BLUE FINISH

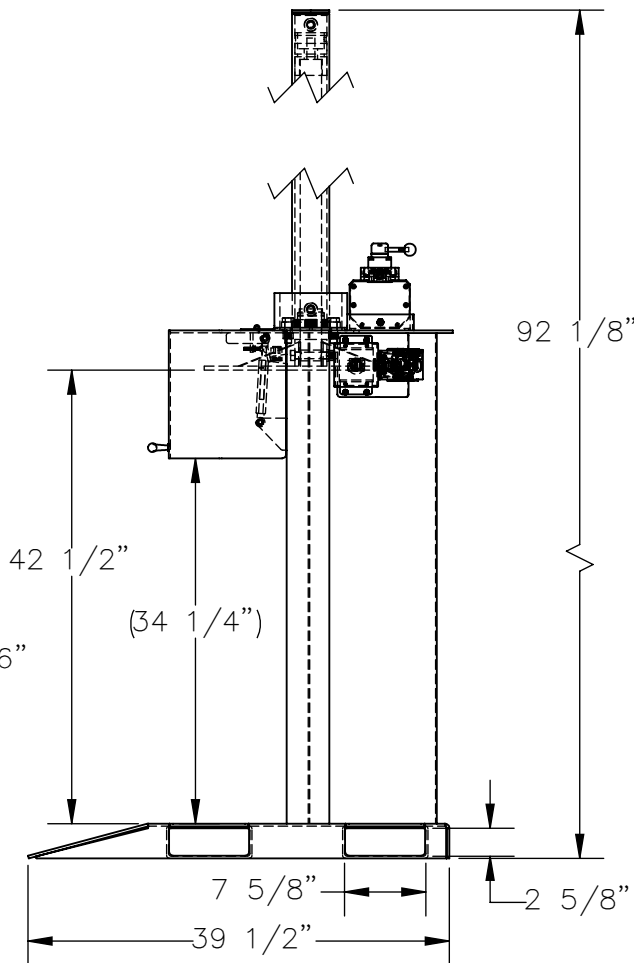

SPECIAL FEATURES

NONE

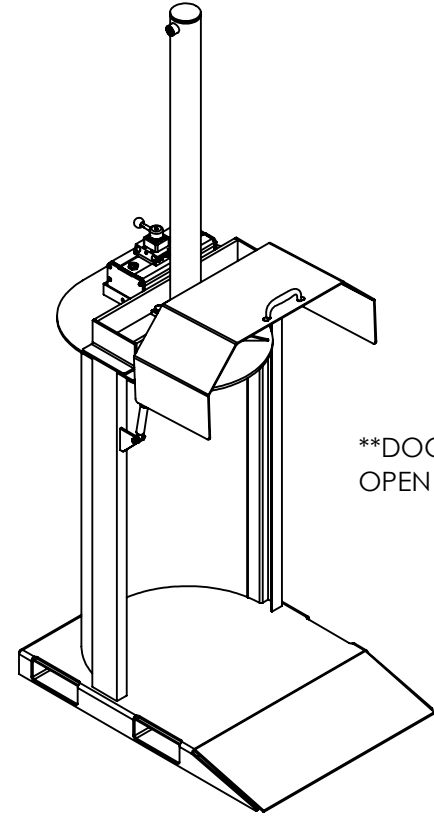

DOOR SHOWN OPEN FOR REFERENCE

DIMENSION TOLERANCE ± 1/4"

FOR INTERNAL USE ONLY PROJECT SIGN OFF	
SALES	
ENG.	
FAB.	
POWER	

I, THE UNDERSIGNED, AGREE THAT THE PRODUCT AS REPRESENTED SATISFIES DESIGN AND DIMENSION REQUIREMENTS. I ALSO ACKNOWLEDGE MY DUTY TO CONFIRM PRODUCT AND INSTALLATION COMPLIANCE WITH ALL APPLICABLE FEDERAL, STATE AND LOCAL REGULATIONS AND STANDARDS.

ANY MODIFIED UNITS ARE NON-RETURNABLE

[] As drawn [] As marked

Signed: _____ Date: _____

Printed Name: _____

LEAD TIME WILL START UPON RECEIPT OF SIGNED APPROVAL DRAWING

DISTRIBUTOR'S NAME:		P.O.#
VESTIL MANUFACTURING		X
DRAWN BY: CRH		W.O.#
DATE: 1/31/2020		X
REFERENCE: X	SCALE: 1:18	SALES: X
QUOTED LEAD TIME: X	QUOTE #	FILE NAME:
	X	22-007-021