

# DC POWERED ALUMINUM QUICK LIFT - PEL-100-A

APPROX WEIGHT: 157.34 lbs.  
DOES NOT INCLUDE WEIGHT OF POWER OR PACKAGING!!!

\*\*\* ANY ADDITIONS, DELETIONS, OR OMISSIONS MUST BE CORRECTED ON THIS DRAWING AS THIS DRAWING WILL BE CONSIDERED ALL INCLUSIVE \*\*\*

ALL GRAPHICS PROVIDED ARE FOR REFERENCE ONLY. IF CERTAIN DIMENSIONS ARE CRITICAL PLEASE VERIFY THOSE DIMENSIONS WITH YOUR SALESPERSON

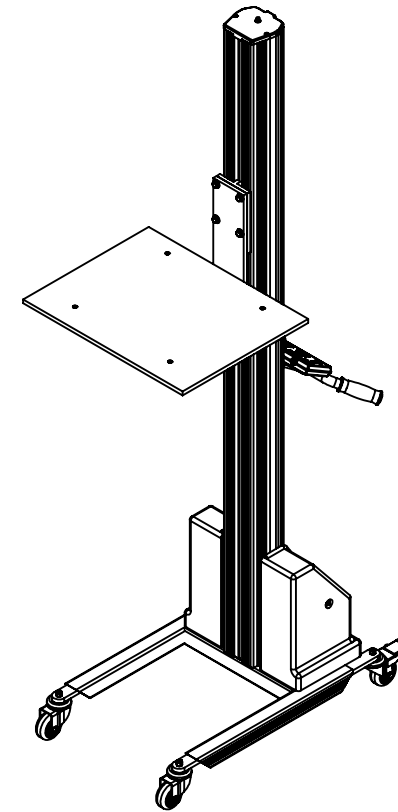
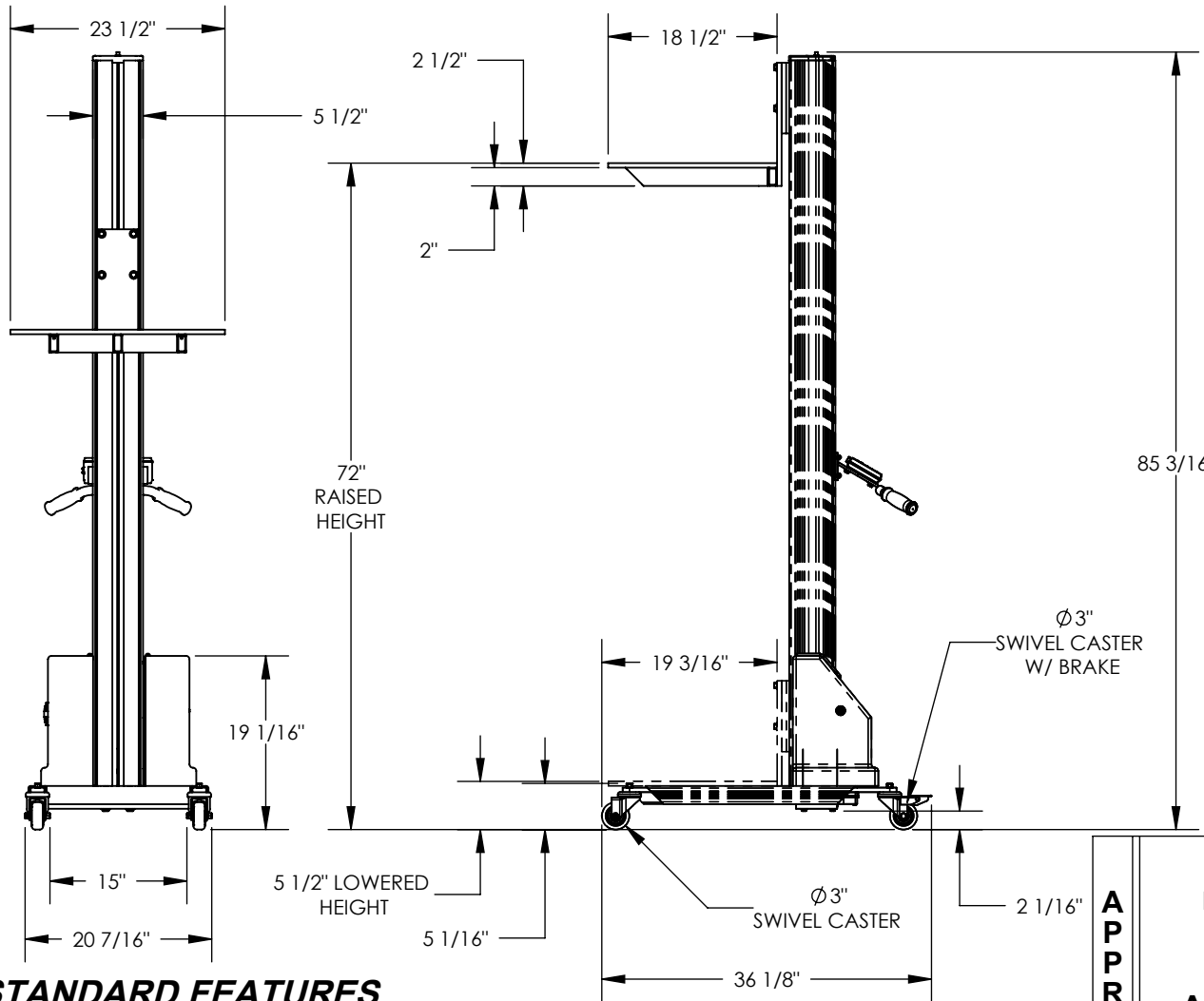

DIMENSION TOLERANCE ± 1/4"

## STANDARD FEATURES

- MODEL NUMBER IS PEL-100-A
- ALUMINUM CONSTRUCTION
- PLATFORM WIDTH 23 1/2"
- PLATFORM LENGTH IS 18 1/2"
- LOWERED HEIGHT IS 5 1/2"
- RAISED HEIGHT IS 72"
- 24V DC POWER
- MAX CAPACITY IS 125 LBS.
- Ø 3" POLY ON POLY STEM CASTERS
- 2 SWIVEL W/ BRAKE & 2 SWIVEL

## SPECIAL FEATURES

NONE

APPROVAL

I, THE UNDERSIGNED, AGREE THAT THE PRODUCT AS REPRESENTED SATISFIES DESIGN AND DIMENSION REQUIREMENTS. I ALSO ACKNOWLEDGE MY DUTY TO CONFIRM PRODUCT AND INSTALLATION COMPLIANCE WITH ALL APPLICABLE FEDERAL, STATE AND LOCAL REGULATIONS AND STANDARDS.

**ANY MODIFIED UNITS ARE NON-RETURNABLE**

[ ] As drawn [ ] As marked

Signed: \_\_\_\_\_ Date: \_\_\_\_\_

Printed Name: \_\_\_\_\_

LEAD TIME WILL START UPON RECEIPT OF SIGNED APPROVAL DRAWING

| FOR INTERNAL USE ONLY<br>PROJECT SIGN OFF |  |
|---|--|
| SALES                                     |  |
| ENG.                                      |  |
| FAB.                                      |  |
| POWER                                     |  |

|                      |          |            |
|----------------------|----------|------------|
| DISTRIBUTOR'S NAME:  |          | P.O.#      |
| VESTIL MANUFACTURING |          | X          |
| DRAWN BY:            | DATE:    | W.O.#      |
| KJY                  | 07/09/13 | X          |
| REFERENCE:           | SCALE:   | SALES:     |
| X                    | 1:20     | X          |
| QUOTED LEAD TIME:    | QUOTE #  | FILE NAME: |
| X                    | X        | 42-007-003 |