

# SOLID DECK STEEL PALLET - SDSP-4048

APPROX WEIGHT: 96.53 lbs.  
 DOES NOT INCLUDE WEIGHT OF POWER OR PACKAGING!!!

\*\*\* ANY ADDITIONS, DELETIONS, OR OMISSIONS MUST BE CORRECTED ON THIS DRAWING AS THIS DRAWING WILL BE CONSIDERED ALL INCLUSIVE \*\*\*

ALL GRAPHICS PROVIDED ARE FOR REFERENCE ONLY. IF CERTAIN DIMENSIONS ARE CRITICAL PLEASE VERIFY THOSE DIMENSIONS WITH YOUR SALESPERSON

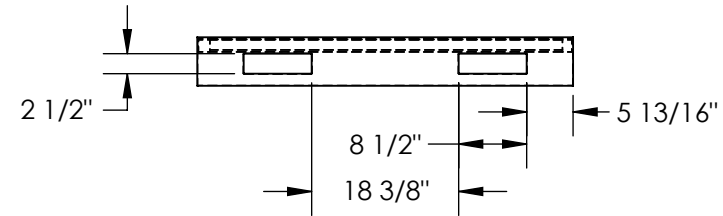
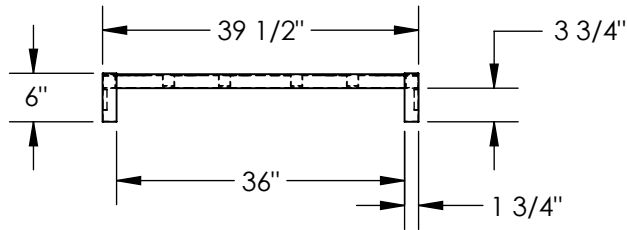
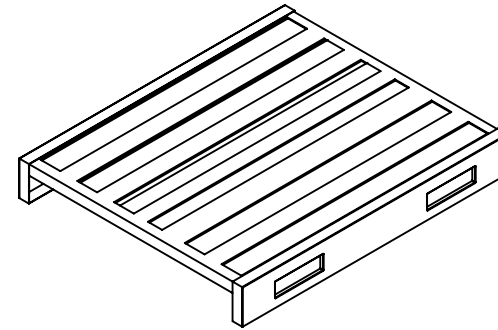
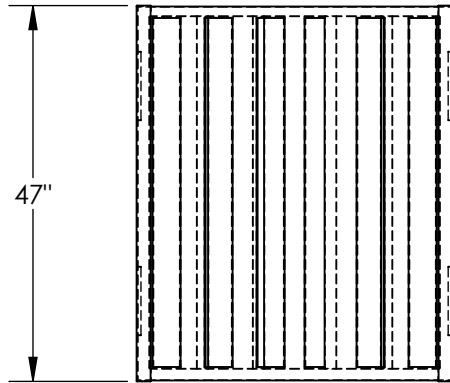

## STANDARD FEATURES

- MODEL NUMBER IS SDSP-4048
- OVERALL WIDTH IS 39 1/2"
- OVERALL LENGTH IS 47"
- OVERALL HEIGHT IS 6"
- FLOOR (STATIC) WEIGHT CAPACITY: 4,000 LBS
- FORK (DYNAMIC) WEIGHT CAPACITY: 3,500 LBS
- UNSUPPORTED PALLET RACK WEIGHT CAPACITY: 2,500 LBS
- FORK POCKETS (W X H): 8 1/2" X 2 1/2"
- OPEN END USABLE SIZE IS 36" WIDE X 3 3/4" HIGH
- GALVANIZED FINISH

## SPECIAL FEATURES

NONE

<b>APPROVAL</b>	I, THE UNDERSIGNED, AGREE THAT THE PRODUCT AS REPRESENTED SATISFIES DESIGN AND DIMENSION REQUIREMENTS. I ALSO ACKNOWLEDGE MY DUTY TO CONFIRM PRODUCT AND INSTALLATION COMPLIANCE WITH ALL APPLICABLE FEDERAL, STATE AND LOCAL REGULATIONS AND STANDARDS.	
	<b>ALL SPECIAL UNITS ARE NON-RETURNABLE</b> <input type="checkbox"/> As drawn <input type="checkbox"/> As marked	
	Signed: _____	Date: _____
LEAD TIME WILL START UPON RECEIPT OF SIGNED APPROVAL DRAWING		

DISTRIBUTOR'S NAME: <b>HOF Equipment Company</b>		P.O.# X
PH: 888-990-1150		W.O.# X
DRAWN BY: DEY	DATE: 11/12/10	SALES: X
REFERENCE: X	SCALE: 1:24	FILE NAME:
QUOTED LEAD TIME: X	QUOTE # X	30-007-198